

Congratulations on your choice of a Crunch subwoofer. This "Quick Start Installation" guide is meant to help you "hook up" and play music. For more detailed information on system setting, speaker and subwoofer configuration, and full specifications by model, visit the website at Crunchcaraudio.com



CAUTION

Always consider consulting a professional audio installer before installing new subwoofers. High power audio systems have the ability create sound levels above 130dB. Extended exposure to high sound pressure levels can cause hearing damage. Always run any new wiring through safe areas that wont interfere with the normal operation of the vehicle.

Subwoofer dimensions

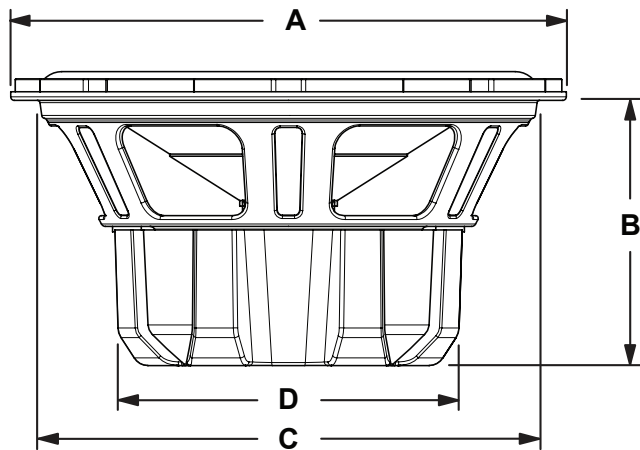

in(mm)	A	B	C	D
CRW12D4	12.25"(311)	5.61"(142.5)	10.94"(142.5)	5.25"(134)

Before you start

It's a good idea to confirm that you have purchased the correct size subwoofers to fit your vehicle. If you have any reservations about being able to complete the installation yourself, we recommend contacting a professional. Be careful as you go. Always disconnect the negative battery terminal before starting any electrical work on the vehicle.

Enclosure types

Sealed

Sealed enclosures offer a range of performance profiles depending on the internal air volume. Larger enclosures will have a smoother more extended response while a small enclosure will have increased output in a more focused frequency range. Sealed enclosures are the simplest to construct but do require that the box be completely air tight.

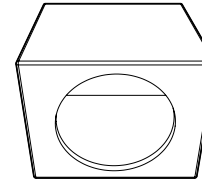

Vented

Vented designs offer the ability to tune the enclosure. Larger enclosures will have a smoother more extended response while a small enclosure will have increased output in a more focused frequency range. Vented enclosures are more difficult to construct but offer more overall output.

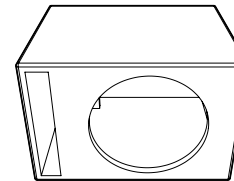

Volume calculation

The internal volume of the enclosure must be determined to insure proper performance. Simply measure height, width and depth of enclosure you intend to build. Subtract the material thickness. Multiply these numbers and divide by 1728 to get the volume in cubic feet.

For enclosures with an angled panel, measure the larger and smaller depths, add these together and divide by two. Use this averaged depth.

$$\text{Enclosure Volume} = \frac{H \times W \times D}{1728}$$

$$D = \frac{D1 + D2}{2}$$

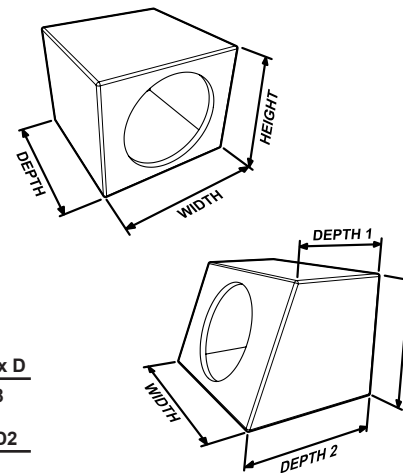

Recommended enclosures

Sealed

	CRW12D4
Height	14"
Width	20.16"
Depth	14"
Vb	1.5 cu ft
F3	43 Hz
Qtc	1.151

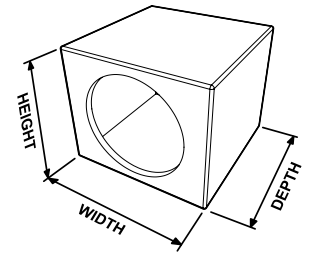

Vented

	CRW12D4
Height	14"
Width	21.1"
Depth	14"
VH (Vent Height)	14"
VW (Vent Width)	0.59"
VL (Vent Length)	12.99"
VA (Vent Area)	31.25 A(10^2)
Vb (Box Volume)	1.5 cu ft
F3	38 Hz
Fb	38 Hz

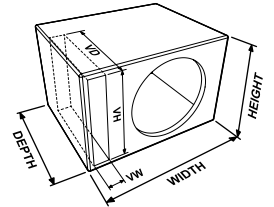

Enclosure construction

- Use 3/4" MDF
- Make sure the woofer mounting panel is full width and height
- Glue all mating surfaces
- Use wood screws
- Use silicone caulk on all internal joints

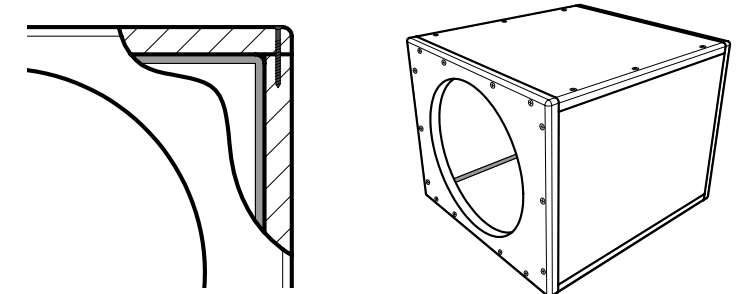

Crossovers

Low Pass (LPF)

A Low pass filter will allow only the bass frequencies to reach the woofer making for a more natural transition to the higher frequency drivers. Check your amplifier's manual for details.

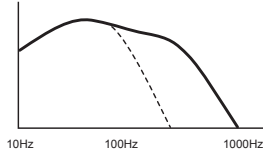

LPF



35 250Hz

Subsonic

We recommend using an electronic subsonic filter. This will help to protect the woofer from extreme low frequency distortion. Many amplifiers are equipped with this type filter. Check your amplifier's manual for details.

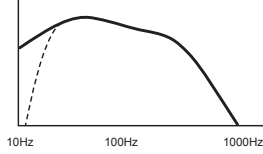

SUBSONIC

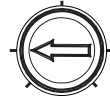

15 35Hz

Wiring

Connections

This subwoofer is equipped with quick disconnect type terminals. Use crimp type terminals or solder the wire directly to the terminals.

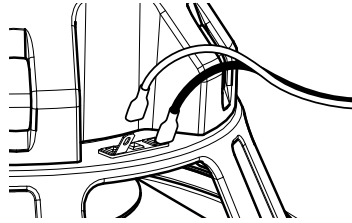

40hm DVC Configurations

Depending on the number of woofers you intend to use, you can configure the wiring to provide the best impedance load for your system. Below are some examples. Consult your amplifier's manual for recommendations.

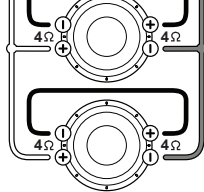
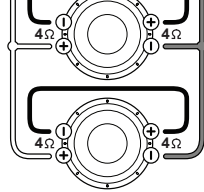
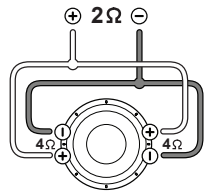
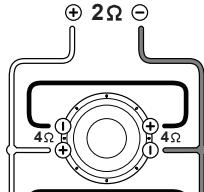
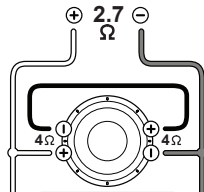
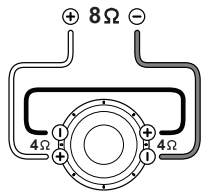

CRUNCH®

Quick Start Installation Guide



CRW12D4

WARRANTY

Maxxsonics USA Inc. warrants this product, to the original consumer purchaser, to be free from defects in material and workmanship for a period of one (1) year from the date of purchase. Maxxsonics USA Inc. will, at its discretion, repair or replace defective products during the warranty period. Components that prove to be defective in materials and workmanship under proper installation and use must be returned to the original authorized Maxxsonics USA Inc. retailer from where it was purchased. A photocopy of the original receipt must accompany the product being returned. The costs associated with removal, re-installation and freight are not the responsibility of Maxxsonics USA Inc. This warranty is limited to defective parts and specifically excludes any incidental or consequential damages connected therewith. To view the full warranty, please visit the website.

Hifonics products are designed and engineered in the USA by

MAXXSONICS®