



MV1000/5i

1000W 5-Channel Class D Marine System Amplifier with Integrated DSP



with
NexD₂[™]
SWITCHING TECHNOLOGY

CONNECTION GUIDE

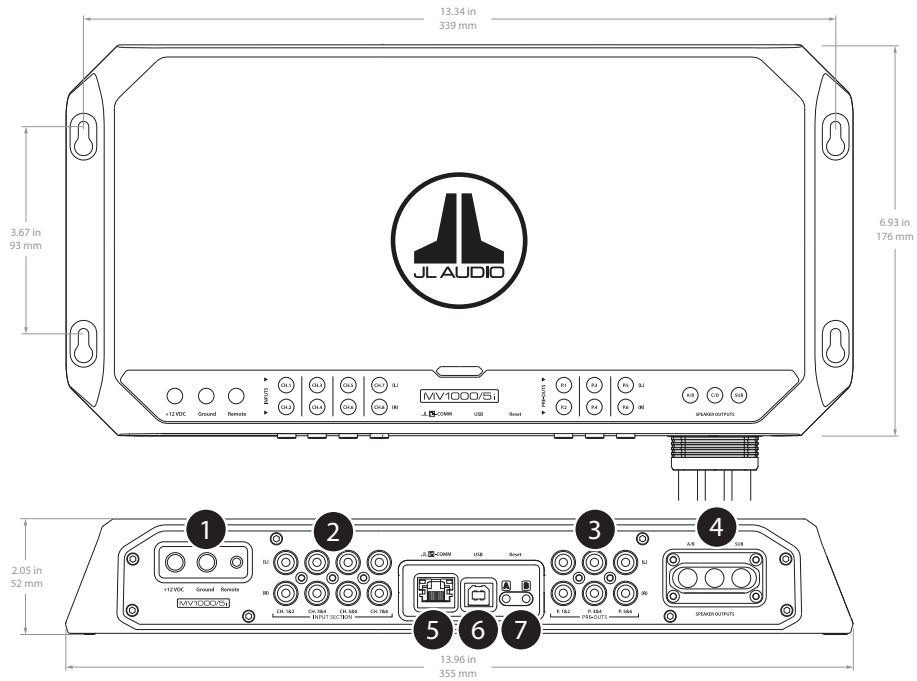

Thank you for purchasing a JL Audio amplifier for your marine sound system.

Your amplifier has been designed and manufactured to exacting standards in order to ensure years of musical enjoyment in your vessel. For maximum performance, we highly recommend that you have your new amplifier installed by an authorized JL Audio dealer. Your authorized dealer has the training, expertise and installation equipment to ensure optimum performance from this product. Should you decide to install the amplifier yourself, please take the time to read this manual thoroughly to familiarize yourself with its installation requirements and setup procedures.

If you have any questions regarding the instructions in this manual or any aspect of your amplifier's operation, please contact your authorized JL Audio dealer for assistance. If you need further assistance, please contact the JL Audio Technical Support Department at technical@jlaudio.com/support.

Installation Applications

This amplifier is designed for operation with 12 volt DC, negative-ground electrical systems. Using this product in vessels with positive ground and/or voltages other than 12V DC may result in damage to the product and will void the warranty. This product is not certified or approved for use in aircraft.

Planning Your Installation

It is important that you take the time to read this manual thoroughly and that you plan your installation carefully. It is very easy to damage electrical systems in modern vessels. Never assume that you have found appropriate wires without consulting a reliable wiring diagram or without analyzing using proper test equipment. If you are uncomfortable or unfamiliar with diagrams or testing methods, please enlist the services of your authorized JL Audio dealer to perform the installation. Your authorized dealer has the training, expertise and installation equipment to ensure optimum performance from this product. The following are some considerations that you must take into account when planning your installation.

Safety Considerations

- Install your amplifier in a dry, well-ventilated location that does not interfere with factory installed systems.
- This product should never be submerged under water or subjected to high-pressure water spray.
- Do not install where it will be directly exposed to the elements, or in the engine compartment, or in any areas of extreme heat. Areas exposed to a heater or hot air should also be avoided.
- When selecting a mounting location, consider the orientation of the amplifier and its associated connections. If possible, position the amplifier vertically, with all connections pointing downward. Wiring and cables should be routed to direct potential condensation and moisture away from the amplifier.
- Securely mount the amplifier so that it does not come loose in the event of a collision or sudden jolt, or as a result of repeated vibrations during normal operation.
- Check before drilling to make sure that you will not be drilling into an exterior panel/hull, fuel tank, fuel line, wiring harness, or other vital system.
- Do not run system wiring outside or underneath the vessel. This is an extremely dangerous practice, which can result in severe damage/injury.
- Protect all system wires from sharp edges by carefully routing them, tying them down and using grommets and loom, where appropriate.
- Secure all wiring as needed, using cable ties or wire clamps to protect them from moving parts and sharp edges.

1 Power Connector

The MV1000/5i's "+12 VDC" and "Ground" connections are designed to accept up to 2 AWG copper wire. Note: Copper Clad Aluminum (CCA) wire is not recommended. Tinned copper power wire is the best choice for marine installations. **4 AWG is the minimum copper wire size for this amplifier.**

To connect the power, ground and remote turn-on wires to the amplifier, back out the set screws on the connector using the supplied hex wrenches. Strip back 3/8 inch (10 mm) of insulation from the end of each wire and insert the bare wire into the receptacle on the power connector plug, seating it firmly so that no bare wire is exposed. While holding each wire in place, tighten each set screw firmly, taking care not to strip the head of the screw. Install the power connector by plugging it into the amplifier's power connector receptacle, pushing firmly.

- +12 VDC:** Run copper wire from the positive (+12V) battery post to the amplifier mounting location. If additional amplifiers are being installed, run the appropriate gauge copper wire for the combined, maximum current draw, and install a fused distribution block near the amplifiers.
- An appropriate fuse or ignition-protected circuit breaker (sold separately) at the main power wire(s) is vital for vessel safety. This must be installed within 7 inches (18 cm) of the battery post connection or in compliance with marine industry standards. If this is the only device connected to this main wire, use a 80 A value. Do not install the fuse or close the circuit breaker until the power wire has been securely connected to the amplifier and all other connections have been made.
- Ground:** This connection should be made to the NEGATIVE battery post. Alternatively, an appropriately equipped and positioned DC ground bus bar near the battery may be used. **All ground connections (source unit and amplifiers) should be made at the same location.**
- Remote:** This connection should be made to the source unit's positive (+12V) remote turn-on output. If your source unit does not have a dedicated remote turn-on output, the amplifier's remote turn-on connection can be connected to +12V via a switch that derives power from an ignition-switched circuit.

2 Input Section

Eight female RCA jacks feed a differential-balanced input section, providing a high degree of input flexibility, and retaining superior noise rejection. This type of input architecture also allows the MV1000/5i to cleanly accept any analog audio signal up to 16 VRMS, without using a line-output converter.

3 Pre-Outs

Six female, RCA jacks deliver line-level, analog audio outputs (Max 4 V RMS) that are compatible with most types of aftermarket equipment. These are configured with the TüN™ Software Interface.

Product Description

The MV1000/5i is a five-channel, Class D marine system amplifier equipped with NexD2™, the second generation of JL Audio's high-speed switching technology. It is engineered to deliver reference-grade audio amplification with outstanding efficiency while also incorporating unprecedented processing power. Instead of traditional analog processing controlled by knobs and switches, MVi amplifiers feature an integrated DSP (Digital Signal Processor). The amplifier and its integrated DSP are configured using an external device (PC, Tablet or Phone), with the appropriate JL Audio TüN™ application installed. (See **What is TüN?** section for more info.)

What is Included

(1) Amplifier	(4) Mounting Screws
(1) Power Connector	(1) 2.5 mm Hex Wrench
(2) Speaker Output Harnesses	(1) 3 mm Hex Wrench
(1) Subwoofer Output Harness	(1) Connection Guide
(1) USB A/B Cable (6 ft./1.8 m)	

Cooling Efficiency Considerations

The outer shell of your JL Audio amplifier is designed to remove heat from the amplifier circuitry. For optimum cooling performance, this outer shell should be exposed to as large a volume of air as possible. Enclosing the amplifier in a small, poorly ventilated chamber can lead to excessive heat build-up and degraded performance. If an installation calls for an enclosure around the amplifier, we recommend that this enclosure be ventilated with the aid of a fan. In normal applications, fan-cooling is not necessary. When mounting the amplifier in an enclosed compartment, make sure there is at least 1 inch (2.5 cm) of space above the amplifier's outer shell to permit proper cooling.

Mounting Considerations

MV amplifiers are equipped with keyhole style mounting holes to simplify installations in confined spaces or vertical-mount applications. Mounting screws may be preinstalled, allowing amplifier connections to be made prior to securing in its final location. See diagram at right.

When selecting the installation location, consider the mounting orientation of the amplifier and its associated connections. If possible, position the amplifier vertically, with all connections pointing downward. Wiring and cables should be routed to direct potential condensation and moisture away from the amplifier. When installed in this manner, the amplifier achieves an IPX2 water-resistance rating.

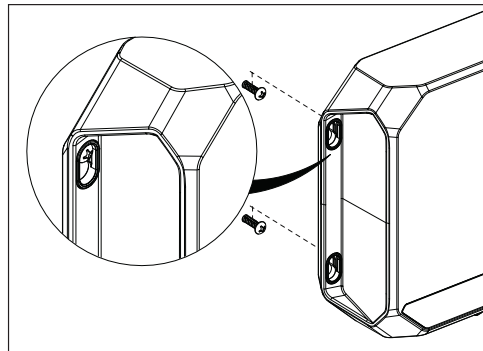

4 Speaker Output Harnesses

Connect the speaker output leads to the corresponding speaker wires. These harnesses and their companion cables are equipped with water-resistant connectors for maximum connection integrity in marine environments.

5 JLid-COMM

Connect optional accessories (MVi-HUB, M-DRC-50, VXi-BTC, MVi-DRCADAPT, etc.) to this port.

6 USB

This USB A/B port permits connection to a computer for configuration and tuning, using TüN™ Software.

7 Reset Buttons

Use a small pin to perform the following:

- (A) **Factory Reset (wipe memory, reboot amp)** - Press and hold the button for 7 seconds. All user settings will be erased and the amplifier will revert to its factory settings!
- (B) **Reboot Amplifier** - Press and release the button. Previous user settings will be retained.

LED Status/Condition Reporting

LEDs located on the chassis top and connection panel are used to communicate amplifier status and condition. Refer to the table below for the location and meaning for each behavior.

LED / Location	Behavior	Status/Condition
LED / Amplifier Top	Flashing Blue	Critical Voltage (too low)
	Flashing Red	Critical Temperature (too hot)
	Flashing Yellow	Excessive Output Current (low impedance/short)
Upper Left LED / JLid-COMM Port	Green	Detecting JLid™ Device
	Blue	JLid™ Connection Success
	Yellow	Invalid JLid™ Device
	Flashing Red	Excessive Current on JLid Port
Upper Right LED / JLid-COMM Port	Flashing Red	Critical Voltage/Temperature
		Excessive Remote Output Current
	Green	Active Connection with TüN™ Software

Wiring Diagram - MV1000/SI

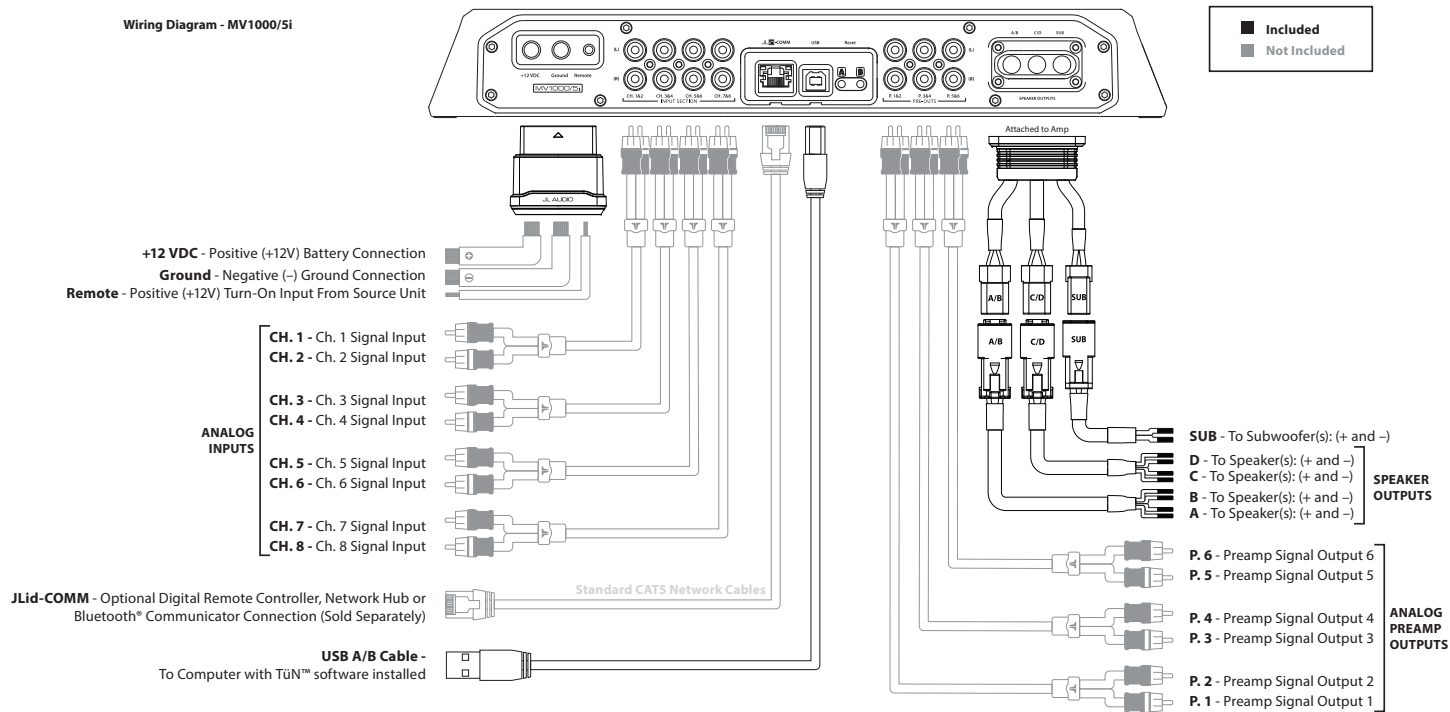

Connections

Power Connector		
Connection	Wire Capacity	Description
+12 VDC (+)	2 AWG	Positive (+12V) Battery Connection
Ground (-)	2 AWG	Negative (GND) Battery Connection
Remote	18 to 10 AWG	Positive (+12V) Remote Turn-On Input from Source Unit
Input Section		
Label	RCA Jack	Description
CH. 1	Black RCA	Channel 1 Signal Input
CH. 2	Red RCA	Channel 2 Signal Input
CH. 3	Black RCA	Channel 3 Signal Input
CH. 4	Red RCA	Channel 4 Signal Input
CH. 5	Black RCA	Channel 5 Signal Input
CH. 6	Red RCA	Channel 6 Signal Input
CH. 7	Black RCA	Channel 7 Signal Input
CH. 8	Red RCA	Channel 8 Signal Input
Pre-Outs (with Independent DSP)		
Label	RCA Jack	Description
P. 1	Black RCA	Preamp Signal Output 1
P. 2	Red RCA	Preamp Signal Output 2
P. 3	Black RCA	Preamp Signal Output 3
P. 4	Red RCA	Preamp Signal Output 4
P. 5	Black RCA	Preamp Signal Output 5
P. 6	Red RCA	Preamp Signal Output 6

Connections

Speaker Outputs			
Label	Wire Color	Description	
A	White	(+) Positive Speaker Output	Ch. 1&2 Bridged (+)
	White/Black	(-) Negative Speaker Output	
B	Gray	(+) Positive Speaker Output	
	Gray/Black	(-) Negative Speaker Output	Ch. 1&2 Bridged (-)
C	Green	(+) Positive Speaker Output	Ch. 3&4 Bridged (+)
	Green/Black	(-) Negative Speaker Output	
D	Purple	(+) Positive Speaker Output	
	Purple/Black	(-) Negative Speaker Output	Ch. 3&4 Bridged (-)
SUB	Brown	(+) Positive Subwoofer Output	
	Brown/White	(-) Negative Subwoofer Output	
Data Connections			
Label	Type	Description/Use	
JLiD-COMM	RJ45 Jack	Optional accessory connections (MVI-HUB, VXI-BTC, etc)	
USB	USB A/B Port	Computer connection to configure TüN™ Software Interface	
Reset	Button - A	Factory Reset (wipe memory, reboot amp) - Press and hold for 7 seconds.	
	Button - B	Reboot Amp - Press and release.	

Specifications

Amplifier Specifications			
Amplifier Topology	2nd-Gen NexD™ High Speed Class D		
Power Supply Type	Unregulated MOSFET Switching		
Operating Voltage	10 - 15V DC		
Min. Copper Power/GND Wire	4 AWG		
Recommended Fuse	80 A		
Standby Current Draw	2.1 mA		
Rated RMS Power @ 14.4V, <1% THD+N	Main @ 4 Ω 75W x 4	Main @ 2 Ω 100W x 4	Main @ 4 Ω Bridged 200W x 2
	Sub @ 4 Ω 400W x 1	Sub @ 3 Ω 500W x 1	Sub @ 2 Ω 600W x 1
	Main @ 4 Ω 60W x 4	Main @ 2 Ω 90W x 4	Main @ 4 Ω Bridged 180W x 2
Rated RMS Power @ 12.5V, <1% THD+N	Sub @ 4 Ω 360W x 1	Sub @ 3 Ω 480W x 1	Sub @ 2 Ω 600W x 1
	Frequency Response		
	Main: >100 / 50 Hz @ 4 Ω, >50 / 50 Hz @ 2 Ω Sub: >100 / 50 Hz @ 4 Ω, >50 / 50 Hz @ 2 Ω		
Damping Factor			
Main: >100 / 50 Hz @ 4 Ω, >50 / 50 Hz @ 2 Ω Sub: >100 / 50 Hz @ 4 Ω, >50 / 50 Hz @ 2 Ω			
IP Rating			
IPX2 (when mounted vertically with connections pointed downward)			
DSP Specifications			
Analog Inputs	Processor	AKM AK738, processing at 24 bit/48 kHz	
	Type	Line-Level, Differential-Balanced	
	Number of Channels	8, via chassis-mounted female RCA jacks	
	Input Voltage Range	250 mV - 16 V RMS	
Analog Preouts	S/N Ratio, (A-weighted, 20 kHz noise bandwidth)	Main: 99 dB (Referred to rated power), 80 dB (Referred to 1 W) Sub: 99 dB (Referred to rated power), 72 dB (Referred to 1 W)	
	Type	6 Line-Level, via chassis-mounted female RCA jacks	
	Max Output Level	4 V RMS	
Dimensions			
L x W x H	13.96 in x 6.93 in x 2.05 in / 355 mm x 176 mm x 52 mm		



What is TüN?

TüN™ is software that you use to configure, tune and control your MVi amplifier, and other JL Audio DSP products. TüN™ automatically recognizes what it is connected to, and allows you to make adjustments with a clear interface specifically set up for that product. TüN™ is available for download for free in a variety of applications, for computers and most handheld devices. For more information, visit: jlaudio.com/tun



For Windows® PC or Mac® computers, TüN™ connects via USB and offers complete control and command of the entire MVi feature set from the comfort of your desk or driver's seat. Software also runs in demo mode, without connected amplifiers, for offline setup or demo purposes. Test drive it for free!



For iPad or Android tablets. Enjoy the full-featured TüN™ software experience on your tablet, with the freedom of a wireless connection via Bluetooth®. Requires VXi-BTC Bluetooth® Communicator.



Wireless connection and streamlined options, for fast and simple amplifier setup. Download *TüN™ Express* for iPhone, iPad and Android phones & tablets. Requires VXi-BTC Bluetooth® Communicator.

Limited Warranty – Marine Amplifiers (USA)

JL Audio warrants this product to be free of defects in materials and workmanship for a period of two (2) years from the original date of purchase. This warranty is not transferable and applies only to the original purchaser from an authorized JL Audio dealer. Should service be necessary under this warranty for any reason due to manufacturing defect or malfunction, JL Audio will (at its discretion), repair or replace the defective product with new or remanufactured product at no charge. Damage caused by the following is not covered under warranty: accident, misuse, abuse, product modification or neglect, failure to follow installation instructions, unauthorized repair attempts, misrepresentations by the seller. This warranty does not cover incidental or consequential damages and does not cover the cost of removing or reinstalling the unit(s). Cosmetic damage due to accident or normal wear and tear is not covered under warranty.

Products installed as original equipment by boat manufacturers are covered by the boat manufacturer's warranty, not JL Audio, Inc.

Warranty is void if the product's serial number has been removed or defaced.

Any applicable implied warranties are limited in duration to the period of the express warranty as provided herein beginning with the date of the original purchase at retail, and no warranties, whether express or implied, shall apply to this product thereafter. Some states do not allow limitations on implied warranties, therefore these exclusions may not apply to you. This warranty gives you specific legal rights, and you may also have other rights, which vary from state to state.

If you need service on your JL AUDIO product:

All warranty returns should be sent to JL Audio's Amplifier Service Facility freight-prepaid through an authorized JL Audio dealer and must be accompanied by proof of purchase (a copy of the original sales receipt). Direct returns from consumers or non-authorized dealers will be refused unless specifically authorized by JL Audio with a valid return authorization number. Warranty expiration on products returned without proof of purchase will be determined from the manufacturing date code. Coverage may be invalidated as this date is previous to purchase date. Non-defective items received will be returned freight-collect. Customer is responsible for shipping charges and insurance in sending the product to JL Audio. Freight damage on returns is not covered under warranty.

For Service Information in the U.S.A. please call JL Audio Customer Service:

(954) 443-1100 9:00 AM – 5:30 PM (Eastern Time Zone)

JL Audio, Inc.

10369 North Commerce Pkwy. Miramar, FL 33025

(Do not send product for repair to this address)

International Warranties:

Products purchased outside the United States of America are covered only by that country's distributor and not by JL Audio, Inc.