



C6-650

6.50 in / 165 mm 2-Way Component System

Systèmes à Composants 165 mm / 25 mm

Sistemas de Componentes de 165 mm / 25 mm

Komponentensysteme, 165 mm / 25 mm

Sistemi a componenti da 165 mm / 25 mm

OWNER'S MANUAL

C6-650-120723

EN

IMPORTANT:

- Installation requires appropriate tools and safety equipment. Professional installation is recommended.
- Before installation, turn off the audio system and disconnect the battery system from the audio system.
- Before cutting or drilling, check for potential obstacles behind mounting surfaces.
- Do not mount this product in an engine compartment or other area of extreme heat.
- Mount this product securely to prevent damage or injury in severe conditions.

!! WARNING

Listen to your audio system at levels appropriate for operating conditions and hearing safety.

FR

IMPORTANT :

- L'installation nécessite des outils et des équipements de sécurité appropriés. Une installation par un professionnel est recommandée.
- Avant l'installation, éteignez le système audio et débranchez la batterie de ce dernier.
- Avant de procéder au découpage ou au perçage, vérifiez l'absence d'obstacles potentiels derrière les surfaces de montage.
- Ne montez pas ce produit dans un compartiment moteur ou une autre zone de chaleur extrême.
- Fixez solidement ce produit pour éviter tout risque de dommages ou de blessures graves.

!! AVERTISSEMENT

Écoutez votre système audio à un volume adapté aux conditions de fonctionnement et à votre audition.

ES

IMPORTANTE:

- Para la instalación se requieren herramientas y equipos de seguridad adecuados. Se recomienda que la instalación la realice un profesional.
- Antes de la instalación, apague el sistema de audio y desconecte el sistema de batería del sistema de audio.
- Antes de cortar o taladrar, compruebe que no haya obstáculos detrás de las superficies de montaje.
- No monte este producto en el compartimento del motor ni en otra zona de calor extremo.
- Monte este producto de forma segura para evitar daños o lesiones en condiciones extremas.

!! ADVERTENCIA

Escuche el sistema de audio a un volumen adecuado, teniendo en cuenta las condiciones de funcionamiento y la seguridad auditiva.

DE

WICHTIG:

- Die Installation erfordert geeignetes Werkzeug und Sicherheitsausrüstung. Es wird eine Installation durch eine Fachkraft empfohlen.
- Schalten Sie vor der Installation das Audiosystem aus und trennen Sie das Batteriesystem vom Audiosystem.
- Kontrollieren Sie vor dem Schneiden oder Bohren, ob sich hinter den Montageflächen mögliche Hindernisse befinden.
- Montieren Sie dieses Produkt nicht in einem Motorraum oder einem anderen Bereich mit extremer Wärme.
- Achten Sie auf eine sichere Befestigung dieses Produkts, um Beschädigungen oder Verletzungen bei starkem Seegang zu vermeiden.

!! WARNUNG

Betreiben Sie Ihr Audiosystem mit einer Lautstärke, die den Umgebungsbedingungen und der Hörsicherheit entspricht.

IT

IMPORTANTE:





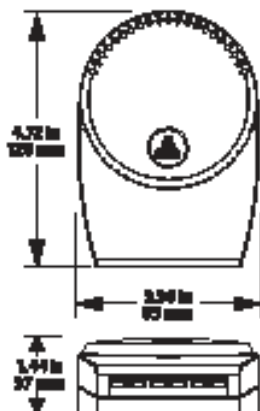
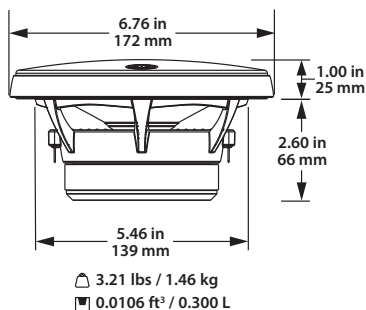
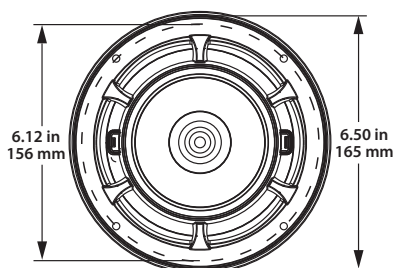
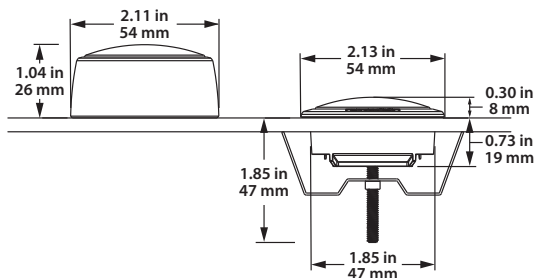

- Per l'installazione si richiedono strumenti e attrezzature di sicurezza idonei. Si consiglia di far eseguire l'installazione da un professionista.
- Prima dell'installazione, spegnere l'impianto audio e scollegare l'impianto della batteria dall'impianto audio.
- Prima di eseguire tagli o perforazioni, verificare la presenza di potenziali ostacoli dietro le superfici di montaggio.
- Non montare questo prodotto in un vano motore oppure in altre aree con temperature estreme.
- Montare il presente prodotto in posizione salda, al fine di evitare danni o lesioni in condizioni avverse.

!! AVVERTIMENTO

Ascoltare l'impianto audio a livelli appropriati per le condizioni di utilizzo e la protezione dell'udito.

C6-650



C6-650	
 TW	1.00 in / 25 mm
 RMS	100 W
 WATT	30 - 100 W
 SPL	87.37 dB @ 1W/1m
 FREQ	53 Hz - 21 KHz ± 3 dB
 ZNOM	4 Ω

EN Product images shown are for illustrative purposes only and may differ from the actual product. Due to continuous product development, all specifications are subject to change without notice. **FR** Les images des produits sont fournies à titre d'illustration uniquement et peuvent différer du produit réel. En raison du développement continu de nos produits, toutes les caractéristiques sont susceptibles d'être modifiées sans préavis. **ES** Las imágenes del producto se muestran solo para fines ilustrativos y pueden diferir del producto real. Dado que el desarrollo de producto es continuo, todas las especificaciones están sujetas a cambios sin previo aviso. **DE** Die gezeigten Produktbilder dienen nur zur Veranschaulichung und können vom tatsächlichen Produkt abweichen. Durch die Weiterentwicklung der Produkte können alle technischen Daten ohne Ankündigung geändert werden. **IT** Le immagini del prodotto mostrate sono solo a scopo illustrativo e potrebbero differire dal prodotto effettivo. A causa dello sviluppo continuo del prodotto, tutte le specifiche potrebbero essere soggette a modifica senza preavviso.

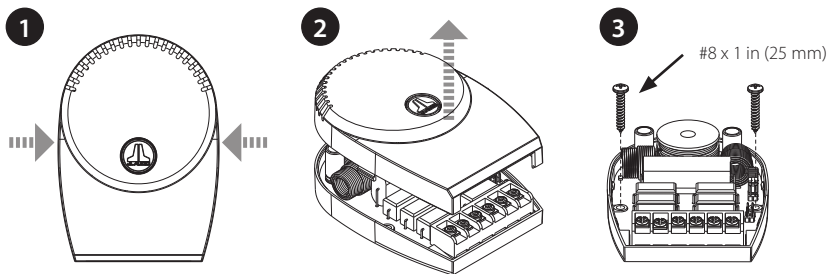
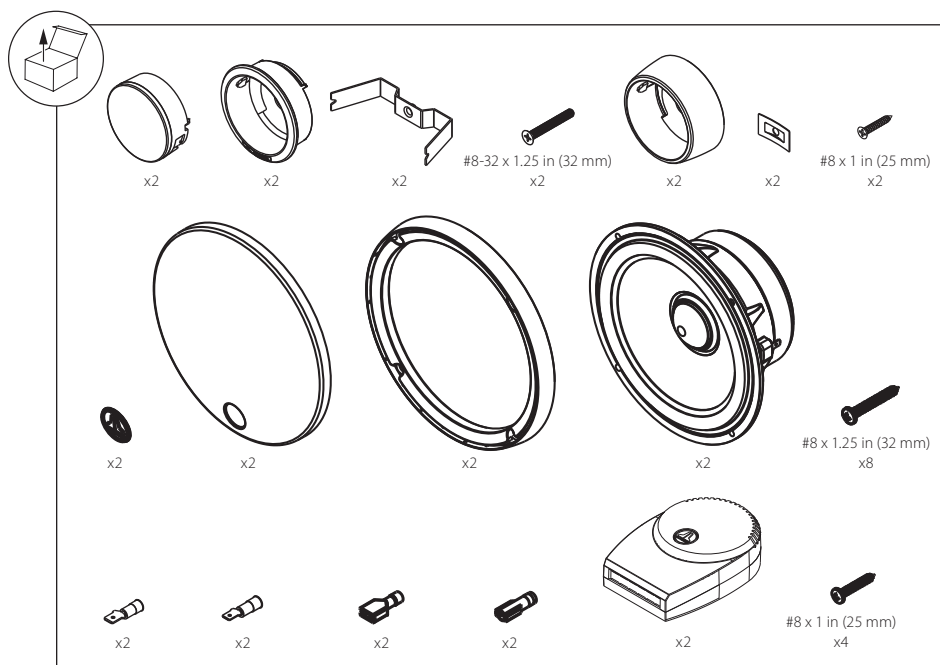

WARNING! Failure to use the appropriate filters supplied in this kit will result in damage or failure of the product and will NOT be covered under warranty. Securely install in dry locations only! Do not install inside of doors!

AVERTISSEMENT! Le fait de ne pas utiliser les filtres appropriés fournis dans ce kit entraînera des dommages ou provoquera un dysfonctionnement du produit et ne sera PAS couvert par la garantie. Fixer de façon sécurisée, dans un endroit sec uniquement! Ne pas installer à l'intérieur des portes!

ADVERTENCIA! Si no se utilizan los filtros adecuados suministrados en este kit, el producto resultará dañado o fallará, y NO estará cubierto por la garantía. Realice la instalación de forma segura solo en lugares secos. No realice la instalación en la parte interior de una puerta.

WARNUNG! Wenn Sie die in diesem Kit enthaltenen Filter nicht verwenden, führt dies zu einer Beschädigung oder einem Ausfall des Produkts und wird NICHT von der Garantie abgedeckt. Für die sichere Befestigung des Produkts sind ausschließlich trockene Standorte geeignet. Installieren Sie das Produkt nicht in Türen.

AVVERTIMENTO! Il mancato utilizzo dei filtri idonei forniti con questo kit comporterà danni o guasti al prodotto e NON saranno coperti dalla garanzia. Installare in modo sicuro solo in ambienti asciutti! Non installare all'interno delle porte!

FLUSH MOUNT (MONTAGE ENCASTRE / MONTAJE EMPOTRADO / EINBAUMONTAGE / MONTAGGIO A FILO)

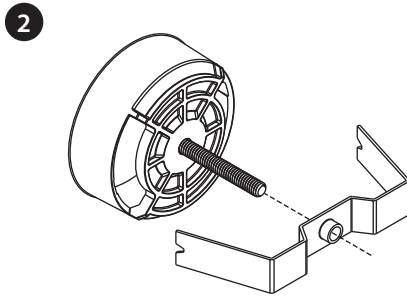
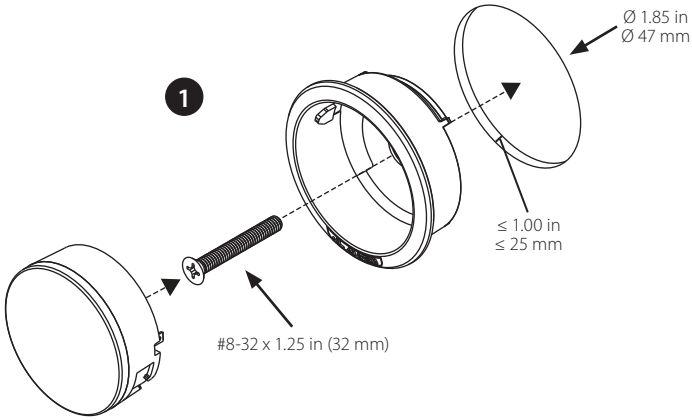

SURFACE MOUNT (MONTAGE EN SURFACE / MONTAJE SOBRE SUPERFICIE / AUFBAUMONTAGE / MONTAGGIO SUPERFICIALE)

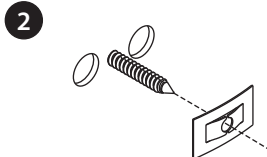
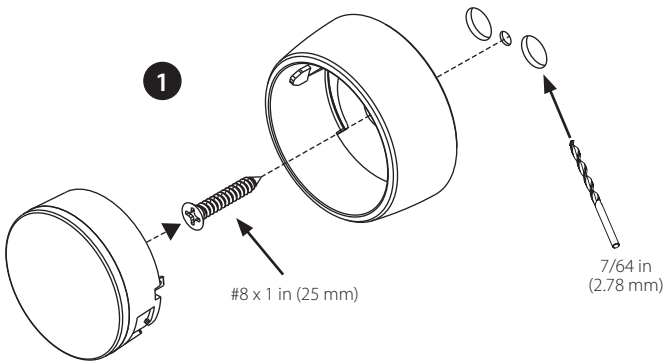

- A** EN Optional
- FR Facultatif
- ES Opcional
- DE Optional
- IT Opzionale

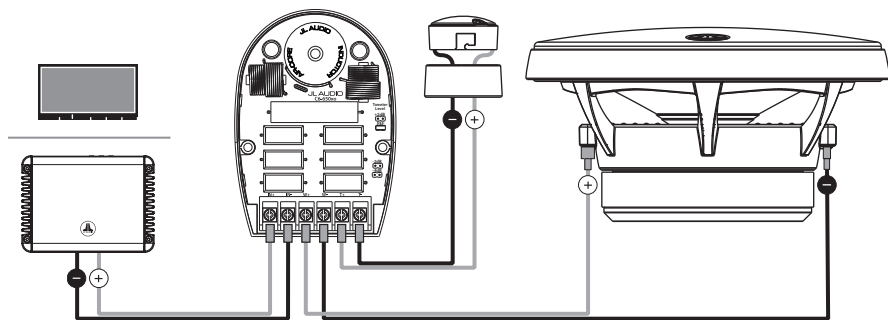
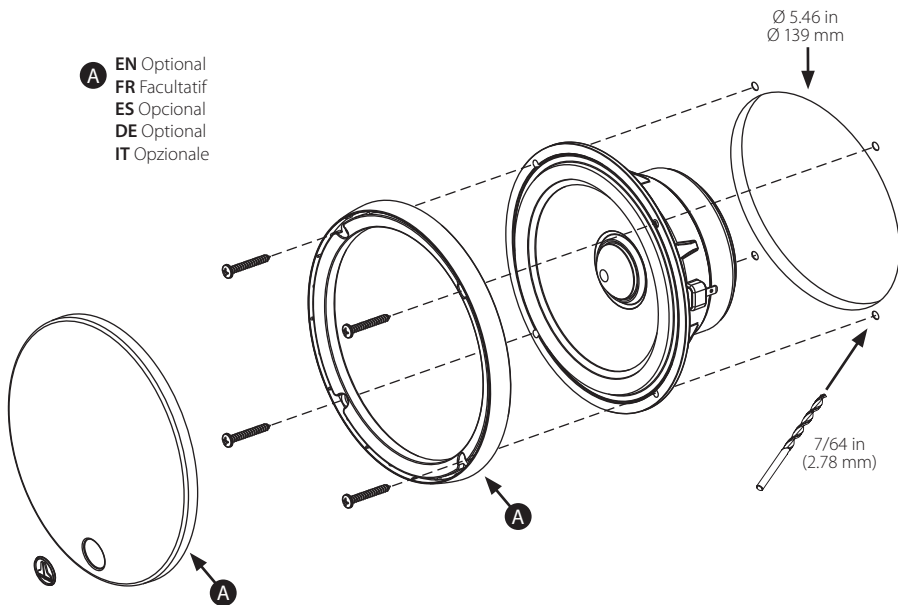

ADJUSTABLE TWEETER LEVEL

(NIVEAU DE TWEETER RÉGLABLE / NIVEL DEL TWEETER AJUSTABLE / ANPASSBARE HOCHTÖNERSTUFE / LIVELLO TWEETER REGOLABILE)

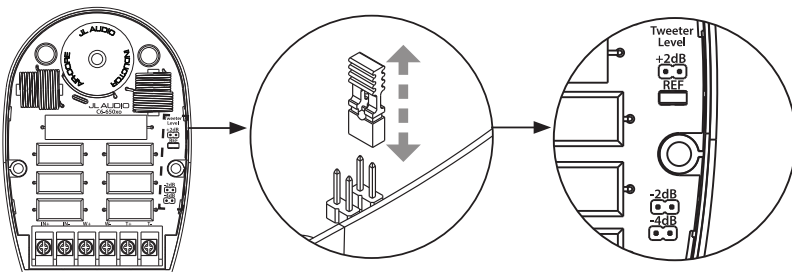



WARRANTY INFORMATION
CAR AUDIO



SKU#011570
©2021 JL Audio, Inc.

USA Limited Warranty

FOR CAR AUDIO PRODUCTS SOLD AT RETAIL:

JL Audio warrants these products to be free of defects in materials and workmanship from the original date of purchase for these periods:

One (1) year from the original date of purchase: Car Speakers and Subwoofers

Two (2) years from the original date of purchase: Car Amplifiers, Electronics, Enclosed Subwoofers, Stealthbox and Connection Products

Note: The Car Amplifier Warranty Period is extended to three (3) years when accompanied with the purchase of a qualifying JL Audio Amplifier Power Connection System and with installation by an authorized JL Audio dealer.

This warranty is not transferable and applies only to the original retail purchaser from an authorized JL Audio dealer in the USA. Should service be necessary under this warranty for any reason due to manufacturing defect or malfunction, JL Audio will (at its discretion), repair or replace the defective product with new or remanufactured product at no charge.

Note: Products purchased from unauthorized dealers are not covered under warranty.

Damage caused by the following is not covered under warranty: accident, misuse, physical abuse, product modification or neglect, failure to follow installation instructions, unauthorized repair attempts, misrepresentations by the seller. Loudspeakers with thermal or over-excursion damage are not covered under warranty. This warranty does not cover incidental, accidental or consequential damages and does not cover the cost of removing or reinstalling products. Cosmetic damage due to improper handling, accident or normal wear and tear or exposure to harsh chemicals is not covered under warranty. JL Audio will not be responsible for restoring or maintaining custom finishes or cosmetic treatments applied to products.

This warranty is void if the product's serial number has been removed, altered or defaced.

Any applicable implied warranties are limited in duration to the period of the express warranty as provided herein beginning with the date of the original purchase at retail, and no warranties, whether express or implied, shall apply to this product thereafter. Some states do not allow limitations on implied warranties, therefore these exclusions may not apply to you. This warranty gives you specific legal rights, and you may also have other rights which vary from state to state.

If you need service on your JL Audio product:

All USA retail warranty returns should be sent to JL Audio freight prepaid through an authorized JL Audio dealer and must be accompanied by proof of purchase (a copy of the original retail sales receipt.) Direct returns from consumers or non-authorized dealers will be refused unless specifically authorized by JL Audio with a valid return authorization number. Warranty expiration on products returned without proof of purchase will be determined from the manufacturing date code. Coverage may be invalidated as this date is prior to purchase date. Return only defective components. (If one speaker fails in a system, return only that speaker component, not the entire system.) Non-defective items received will be returned freight-collect. Customer is responsible for shipping charges and insurance in sending the product to JL Audio. Freight damage on returns is not covered under warranty.

JL Audio Customer Service:

1-954-443-1100

9:00 AM – 5:00 PM (Eastern Time Zone)

JL Audio Technical Support:

www.jlaudio.com/support

Original Equipment Warranty

For JL Audio products installed as original equipment by a boat or vehicle manufacturer, warranty coverage is provided within the boat or vehicle manufacturer's warranty program. Please contact your boat dealer or manufacturer.

International Warranty

JL Audio Car Audio products are warrantied against defects in materials and workmanship for a minimum time period as stated in the USA warranty above, beginning on the date of purchase from a Dealer authorized by a JL Audio Distributor. The warranty is only valid within the country of purchase and products are covered by each country's JL Audio Distributor warranty program. To find your country's Distributor please visit this link: www.jlaudio.com/pages/dealer-locator

Consumers in the EEA countries and the Russian Federation are protected by local consumer law and benefit from local statutory warranties.

JL Audio reserves the right to change or modify any of the terms and conditions contained in this Warranty Statement, at any time and in our sole discretion. Any changes or modification will be effective immediately upon posting of the revisions on the JL Audio website at www.jlaudio.com/warranty, and you waive any right you may have to receive specific notice of such changes or modifications.