

OWNER'S MANUAL

C 650

6.50-inch (165 mm) 2-Way Component System

*Thank you for choosing a JL Audio Evolution™ C2 Component System
for your automotive sound system.*

*These Evolution™ Speakers have been designed and manufactured to
exacting standards in order to ensure years of musical enjoyment in your
vehicle. For maximum performance, we highly recommend that you have
your new speakers installed by an authorized JL Audio dealer. Your
authorized dealer has the training, expertise and installation equipment
to ensure optimum performance from this product. Should you
decide to install the speakers yourself, please take the time
to read this manual thoroughly so as to familiarize yourself
with its installation requirements and setup procedures.*

*If you have any questions regarding the instructions in this
manual or any aspect of your amplifier's operation, please contact your
authorized JL Audio dealer for assistance. If you need further assistance,
please call the JL Audio Technical Support Department
at (954) 443-1165 during business hours.*



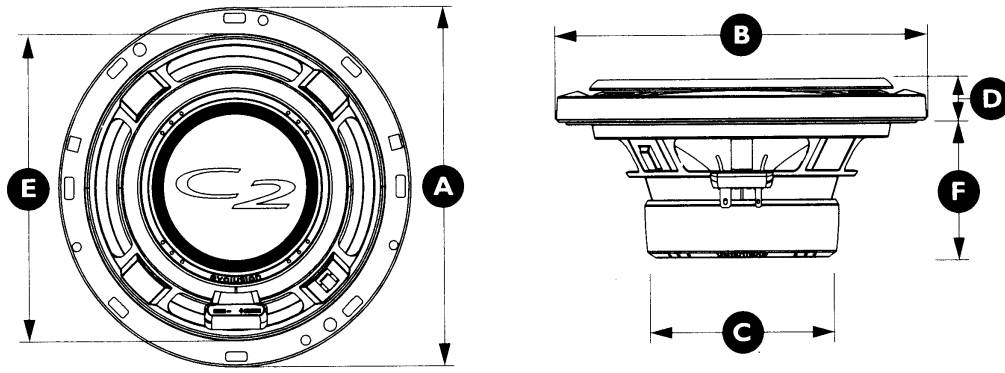

Woofer Physical Dimensions	
Frame Outer Diameter (A)	6.50 in. / 165.0 mm
Grille Tray Outer Diameter (B)	6.84 in. / 173.7 mm
Magnet Outer Diameter (C)	3.15 in. / 80.0 mm w/o cover
Frontal Grille Protrusion (D)	0.85 in. / 21.6 mm
Mounting Hole Diameter (E)	5.56 in. / 141.3 mm
Mounting Depth (F)	2.44 in. / 61.9 mm w/o cover

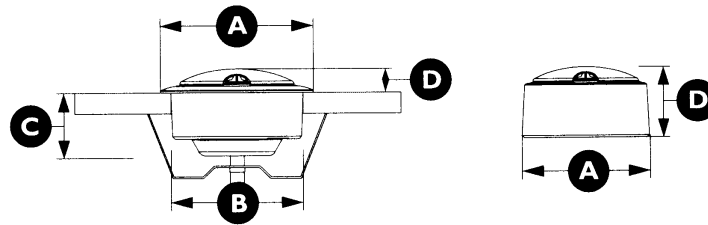

Tweeter Fixture Physical Dimensions	Flush-Mount	Surface-Mount
Fixture Outer Diameter (A)	1.87 in. / 47.5 mm	1.69 in. / 42.9 mm
Fixture Mounting Hole Diameter (B)	1.625 in. / 41.3 mm	N/A
Fixture Mounting Depth (C)	0.76 in. / 19.3 mm	N/A
Tweeter Frontal Protrusion (D)	0.29 in. / 7.4 mm	0.92 in. / 23.4 mm

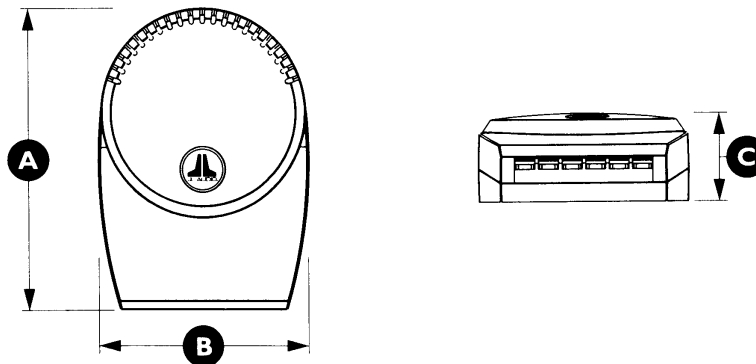

Crossover Network Physical Dimensions	
Height (A)	4.72 in. / 119.9 mm
Width (B)	3.36 in. / 85.3 mm
Depth (C)	1.44 in. / 36.6 mm

Due to ongoing product development, all specifications are subject to change without notice.

C2-650 SPECIFICATIONS:

Woofers: Injection-molded, Mica-filled, Polypropylene Cone, Butyl Rubber Surround, 1 in. Voice Coil on Kapton® Former, Flat, Symmetrical Roll Spider, Ferrite Magnet

Tweeter: 0.75 in. (19 mm) Silk Dome, Ferrofluid Cooling / Damping, Neodymium Magnet

Crossover Networks: 1st Order Low-Pass Filter, 2nd Order High-Pass Filter, 3-Position Adjustable Tweeter Level, Premium Mylar® Capacitors Premium Air-Core Inductors

Continuous Power Handling: 60 Watts

Recommended Amp Power: 15-100 Watts per channel (RMS)

Efficiency: 91.0 dB @ 1W/1m | 97.0 dB @ 1W/0.5m

Sensitivity: 94.0 dB @ 2.83V/1m

Nominal Impedance: 4 ohm

Frequency Response: 59 Hz - 22 KHz ± 3 dB

Included Components and Parts:

- Two C2-650cw 6.50-inch (165 mm) Woofers
- Two C2-075ct 0.75-inch (19 mm) Tweeters
- Two C2-650-XO Crossover Networks
- Two Flush-Mount Tweeter Fixtures
- Two Surface-Mount Tweeter Fixtures
- Two Metal Spring Clips for Tweeter Fixtures
- Two Grille Assemblies
- Two Self-Adhesive JL Audio Nameplates for Grilles
- Twelve #8 x 1.2 inch (30 mm) Sheet Metal Screws
- Four #6 x 1-inch (25 mm) Sheet Metal Screws
- Two 1.18-inch (30 mm) Machine Screws
- Eight Mounting Clips for Woofer Mounting
- Two 4.7 mm Female Crimpable Connectors
- Two 2.8 mm Female Crimpable Connectors
- Two 4.7 Male Crimpable Connectors
- Two 2.8 mm Male Crimpable Connectors
- Twelve Crimpable Spade Connectors

GETTING STARTED

- Turn off the audio system. It is also advisable to disconnect the negative (-) terminal of your vehicle's battery whenever performing installation work.
- Before cutting, drilling or inserting any screw, check clearances on both sides of the planned mounting surface. Also check for any potential obstacles, such as window tracks and motors, wiring harnesses, etc. Check both sides of the vehicle, many vehicles are not symmetrical!
- Always wear protective eyewear.

SPEAKER PLACEMENT CONSIDERATIONS

In most cases, your speakers will be placed into factory speaker locations. If you have some speaker mounting flexibility, keep the following in mind: Lower mounting locations, such as the lower front corner of a door or a kick-panel provide the greatest path length distances for the sound emitted by the speakers. For this reason, they are generally more desirable than higher mounting locations. Higher mounting locations will usually result in extreme near-side soundstage bias which compromises the stereo listening experience.

GETTING STARTED

- Turn off the audio system. It is also advisable to disconnect the negative (-) terminal of your vehicle's battery whenever performing installation work.
- Before cutting, drilling or inserting any screw, check clearances on both sides of the planned mounting surface. Also check for any potential obstacles, such as window tracks and motors, wiring harnesses, etc. Check both sides of the vehicle, many vehicles are not symmetrical!
- Always wear protective eyewear.

CROSSOVER NETWORK INSTALLATION

The crossover networks supplied with your C2 System should be installed in a dry location inside your vehicle. **DO NOT INSTALL THEM INSIDE OF A DOOR!** Doors often get wet on the inside, which can damage your crossover networks and could potentially damage your entire sound system. The crossovers can be screwed into a solid surface via two holes located under the protective cover of the case. To access these holes, simply squeeze the sides of the cover while gently pulling the cover away from the base. Make sure that your mounting location will not cause damage to wiring, fuel lines, brake lines or any other vital component of your vehicle. Once you have screwed the case in and made your connections, snap the protective cover back into place.

!! WARNING

It is absolutely vital that your component system is connected as shown in this manual. Failure to connect the system as shown may result in damage to your speakers which is **NOT** covered under warranty.

Do not substitute different crossover networks into your C2 System. Do not use crossover networks intended for different C2 models.

Amplifier
Output

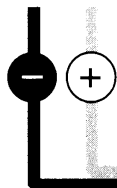

TWEETER PROTECTION

The C2 crossover networks are equipped with an advanced electronic tweeter protection circuit designed to minimize the possibility of tweeter failure. This electronic device monitors current going to the tweeter and will disconnect the tweeter from the signal when it senses overload. Should this occur while listening to the audio system, simply reduce the volume for a few seconds and the protection circuit will reset itself automatically.

CROSSOVER NETWORK ADJUSTMENT

The crossover networks have been designed to allow tonal adjustments to the tweeter level. These adjustments make it possible to fine-tune your system to suit your listening preferences and to compensate for various speaker mounting applications.

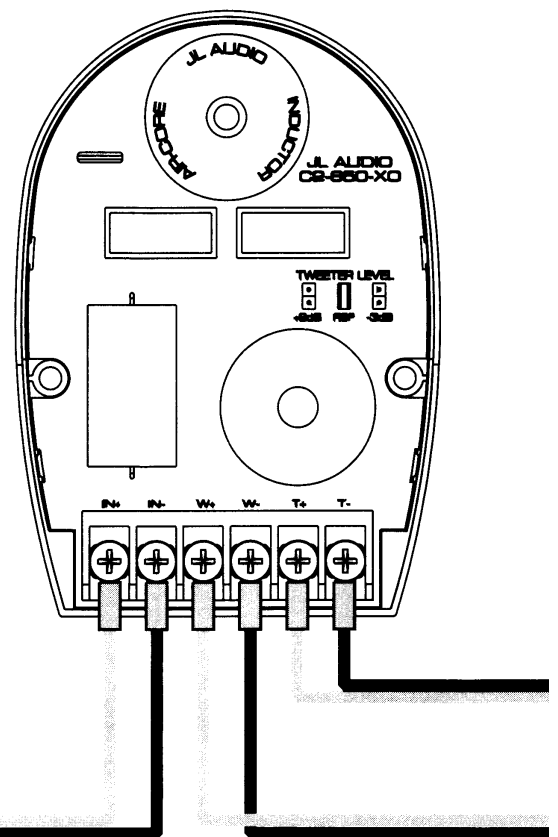

ADJUSTABLE TWEETER LEVEL

C2 crossover networks also provide three levels of tweeter adjustability designed to compensate for different mounting locations, vehicle interiors and personal taste. These levels are selectable via a set of pins located under the clear cover of each crossover case. We recommend that you begin listening in the “REF” (Reference) position. To find the optimum tonal balance in your installation, experiment with alternate tweeter level settings by moving the pins. It is safe to switch jumpers while the system is playing.

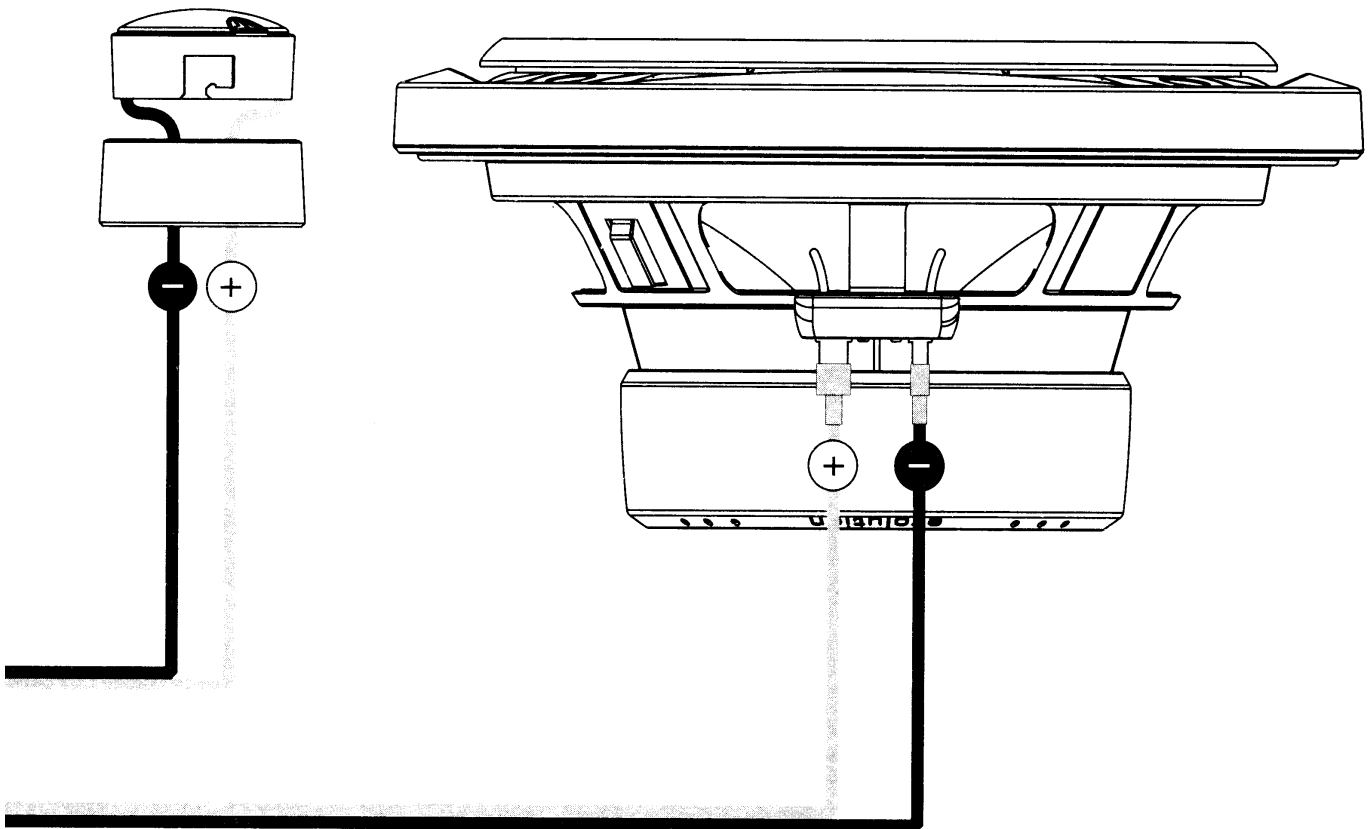
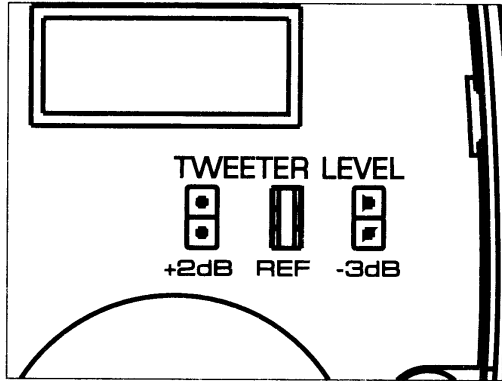

SPEAKER PLACEMENT CONSIDERATIONS

A component system gives you the ability to place the woofer and tweeter separately in your vehicle interior. This can be good or bad, depending on how it's done. As a general rule, the tweeters should be placed relatively close to the woofers for best tonal balance and most coherent imaging (the closer, the better). Any separation greater than 8 inches (20 cm) is likely to result in degraded sound quality.

Avoid placing tweeters where they will be blocked by objects in the interior of the car (including seated occupants). When selecting a mounting location, look at both sides of the car to make sure that this location is clear on both sides.

You can always experiment with tweeter placement before committing to a final mounting location. Simply connect the rest of the system and allow plenty of wire length for the tweeters. Using Velcro® or similar material, attach the tweeters in different locations until you find the one where they perform best.

Woofers will usually be placed into factory speaker locations. If you have some woofer mounting flexibility, keep the following in mind: Lower mounting locations, such as the lower front corner of a door or a kick-panel provide the greatest path length distances for the sound emitted by the woofer. For this reason, they are generally more desirable than higher mounting locations. Higher mounting locations often result in extreme near-side soundstage bias which compromises the stereo listening experience.

DIAGRAM A: LESS DESIRABLE SPEAKER PLACEMENT

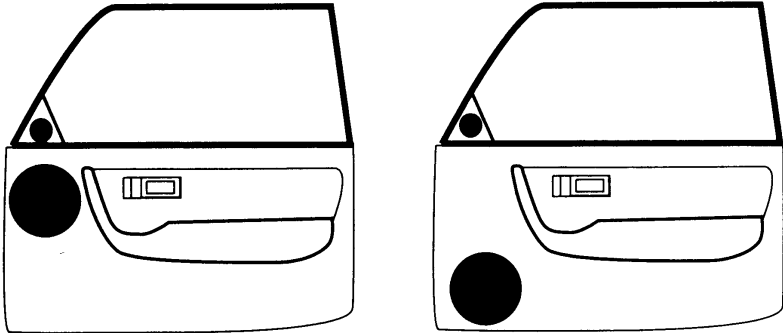
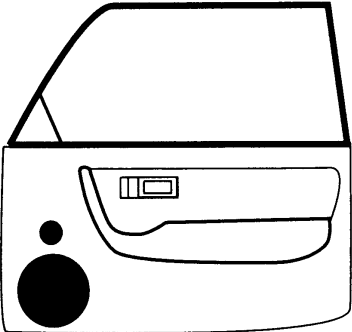

DIAGRAM B: MORE DESIRABLE SPEAKER PLACEMENT



SPEAKER INSTALLATION

The speaker should be installed in one of the following ways depending on location:

Factory Location: If you will be using the factory speaker wires, it may be necessary to change the terminations. This may be accomplished by using an adaptor plug or simply by cutting the factory connector off and using the supplied crimp connectors to terminate the speaker wires. The large connector is for the positive terminal and the small connector is for the negative terminal of each C2-650.

You may also choose to run new speaker wires... Run speaker wire to the desired mounting locations. If you are running wires into a door, use existing factory wiring boots whenever possible. If you are drilling new holes, file their edges and install rubber grommets into each hole. Wires should then be covered with a protective, flexible PVC sleeve and then run through the door jamb. Make sure that the wires will clear door hinges and other structures in the door. If you are unsure about any part of this process, please contact your JL Audio dealer for installation help.

!! WARNING

Double check the clearance for both speakers before proceeding. Many cars are different from one side to the other!

Your new speakers have been designed to install, without modifications, into most vehicles that accept a 6.5-inch (165 mm) speaker. Most factory 6.5 -inch speakers use four mounting screws which will line up with the mounting holes on your C2-650 speakers. Others use a 3-hole mounting system which is accommodated by a separate set of mounting holes on the frames of your C2-650 speakers.

It is absolutely vital that the speaker frame fits into the mounting hole cleanly. This must be checked prior to tightening the screws. Do not force the frame into a hole that is too small. Do not tighten the speaker onto an uneven surface. This will damage your speakers. The speaker should also fit so that air does not leak around the mounting flange. Air leaks will cause a severe degradation in sound quality. Seal any air leaks with an automotive-grade sealant material.

Install as shown in Diagram C (page 9). Use the supplied mounting clips unless the factory holes already feature threaded inserts. Hand-tighten the screws evenly to avoid bending the speaker frame!

Custom Location: Run speaker wire to the desired mounting location. If you are running wires into a door, use existing factory wiring boots whenever possible. If you are drilling new holes, file their edges and install rubber grommets into each hole. Then, cover the wires with a protective PVC sleeve and run them through the door jamb. Make sure that the wires will clear door hinges and other structures in the door. If you are unsure about any part of this process, please contact your JL AUDIO dealer for installation help.

!! WARNING

Double check the clearance for both speakers before proceeding. Many cars are different from one side to the other!

Select an even surface. Tightening a speaker onto an uneven surface can damage it. Use the supplied template to mark the desired mounting location. Mark the center and the outline of the mounting hole as well as the mounting screw positions. Before drilling or cutting on your interior panels, use a utility knife to cut any fabric, vinyl or leather from hole locations. These materials can easily be snagged by a drill or a saw, causing damage to the panel and possible bodily injury. Drill four 1/8-inch (3 mm) holes for the speaker's mounting screws at the positions you have marked. Also drill a pilot hole in the center of the speaker mounting hole at this time. Then, using a saber saw, make the circular cut out for the speaker. File any rough edges. Insert the mounting clips with the flat side towards the speaker as shown in Diagram D (page 9).

It is absolutely vital that the speaker frame fits into the mounting hole cleanly. This must be checked prior to tightening the screws. Do not force the frame into a hole that is too small. Do not tighten the speaker onto an uneven surface. This will damage your speakers. The speaker should also fit so that air does not leak around the mounting flange. Air leaks will cause a severe degradation in sound quality. Seal any air leaks with an automotive-grade sealant material.

Connect the speaker wires, observing correct polarity, and install the speaker and grille assembly as shown in Diagram D (below). Hand-tighten the screws evenly to avoid bending the speaker frame!

The included JL Audio logo name badges should be affixed to the circular indented area in the lower part of each grille assembly. If the grille assembly is not used, the JL Audio logo badges can be affixed elsewhere as creative additions to your installation.

!! WARNING

Hand-tighten the screws evenly in a criss-cross pattern to avoid bending the speaker frame or stripping the mounting clips.

DIAGRAM C: FACTORY LOCATION WOOFER INSTALLATION

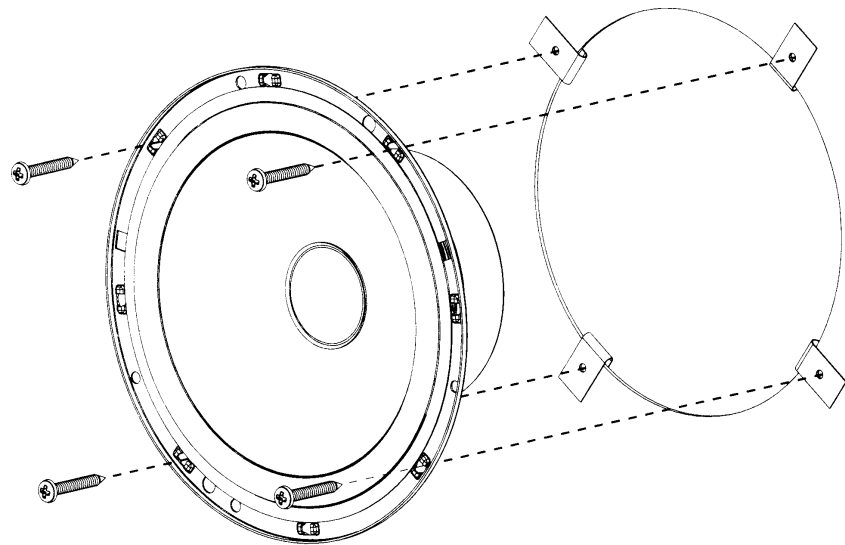
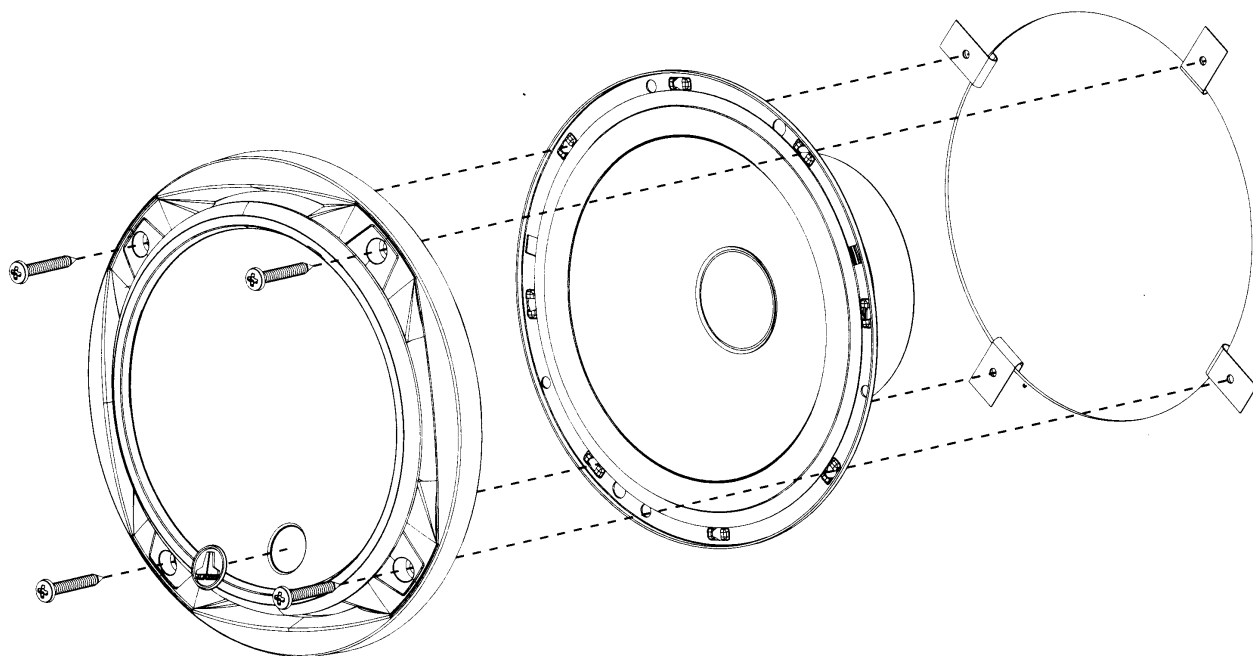

DIAGRAM D: CUSTOM LOCATION WOOFER INSTALLATION



TWEETER INSTALLATION

First, run speaker wires from the tweeter output of the crossover (see diagrams on page 5) to the desired tweeter mounting locations, observing the same precautions as mentioned in the woofer installation section. Terminate the wires with the supplied 2.8 mm and 4.7 mm male crimpable connectors.

TWEETER FIXTURE INSTALLATION

The dome tweeters supplied with your C2-650 system have been designed for maximum mounting versatility. There are two primary methods by which the tweeters can be mounted in your vehicle:

Flush-Mount: For tweeter integration in a clean, unobtrusive manner, you will use the supplied flush-mount cups. This compact mounting fixture is installed using the method illustrated in Diagram E and requires a mounting hole with a diameter of 1.625 in. (41.28 mm).

At least 0.76 in. (19.3 mm) of clearance is required behind the mounting surface of the tweeter for the spring clips and 1.18-inch machine screws used in mounting the fixture. It may be necessary in some limited depth applications to cut down the length of the machine screw, or to use a shorter screw (not supplied). Hand-tighten the machine screw until the fixture is secure. Run the tweeter's wires through the hole, make appropriate connections and insert the tweeter into the mounting cup. Push the tweeter down and rotate it clockwise to lock it into place.

Surface-Mount: In this application, you will not need to cut large holes in your vehicle's panels for the tweeters. You will only need to drill a hole for the wires and two smaller holes for the mounting screws. This application is useful when mounting the tweeters to a panel that has insufficient clearance behind it for the tweeter's magnet structure.

Using the fixture as a template, mark the screw hole locations and a location in the center of the fixture for the wire hole. Remove the fixture and drill pilot holes for the screws and a 1/8-inch (3 mm) for the wires. Use the supplied #6 x 1-inch sheet metal screws to secure the fixture as shown in Diagram F (hand-tighten). Run the tweeter's wires through the hole, make appropriate connections and insert the tweeter into the mounting cup. Push the tweeter down and rotate it clockwise to lock it into place.

DIAGRAM E: FLUSH-MOUNT TWEETER INSTALLATION

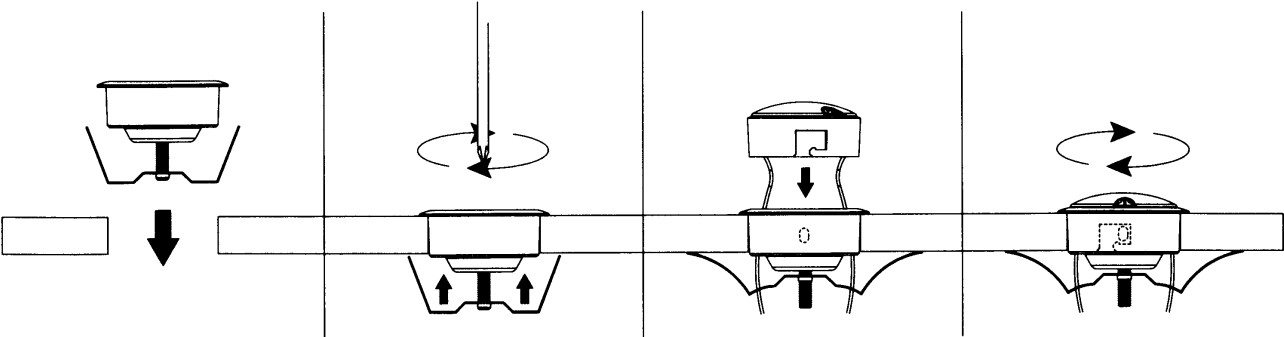
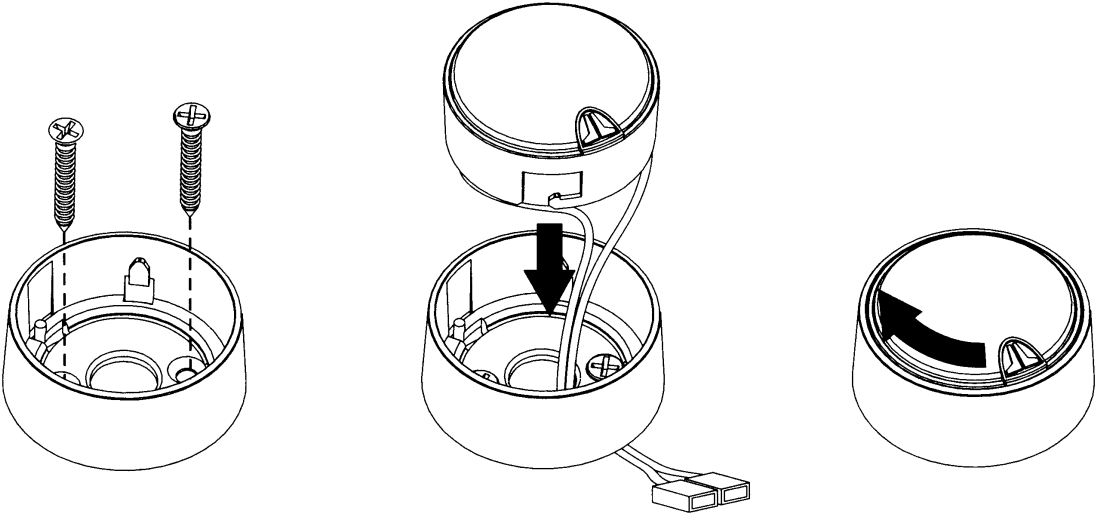

DIAGRAM F: SURFACE-MOUNT TWEETER INSTALLATION



LIMITED WARRANTY - AUTOMOTIVE SPEAKER SYSTEMS (USA)

JL AUDIO warrants these speakers (and crossover networks, where applicable) to be free of defects in materials and workmanship for a period of **one (1) year**.

This warranty is not transferable and applies only to the original purchaser from an authorized JL AUDIO dealer. Should service be necessary under this warranty for any reason due to manufacturing defect or malfunction, JL AUDIO will (at its discretion), repair or replace the defective product with new or remanufactured product at no charge. Damage caused by the following is not covered under warranty: accident, misuse, abuse, product modification or neglect, failure to follow installation instructions, unauthorized repair attempts, misrepresentations by the seller. This warranty does not cover incidental or consequential damages and does not cover the cost of removing or reinstalling the unit(s). Cosmetic damage due to accident or normal wear and tear is not covered under warranty.

Any applicable implied warranties are limited in duration to the period of the express warranty as provided herein beginning with the date of the original purchase at retail, and no warranties, whether express or implied, shall apply to this product thereafter. Some states do not allow limitations on implied warranties, therefore these exclusions may not apply to you. This warranty gives you specific legal rights, and you may also have other rights which vary from state to state.

If you need service on your JL AUDIO product:

All warranty returns should be sent to JL AUDIO freight prepaid through an authorized JL AUDIO dealer and must be accompanied by proof of purchase (a copy of the original sales receipt.) Direct returns from consumers or non-authorized dealers will be refused unless specifically authorized by JL AUDIO with a valid return authorization number. Warranty expiration on products returned without proof of purchase will be determined from the manufacturing date code. Coverage may be invalidated as this date is previous to purchase date. Return only defective components. If one speaker fails in a system, return only that speaker component, not the entire system. Non-defective items received will be returned freight-collect. Customer is responsible for shipping charges and insurance in sending the product to JL AUDIO. Freight damage on returns is not covered under warranty.

For Service Information in the U.S.A. please call

JL Audio Customer Service: (954) 443-1100

9:00 AM – 5:30 PM (Eastern Time Zone)

JL Audio, Inc

10369 North Commerce Pkwy.

Miramar, FL 33025

International Warranties:

Products purchased outside the United States of America are covered only by that country's distributor and not by JL Audio, Inc.