



Instruction Disclaimer

Dennis Kirk provides instructions to help our customers better understand how to install the products we sell. The instructions are exact copies of what the manufacturer includes with the product being sold.

That means the quality and accuracy of the instructions is solely dependent on what the manufacturer produces. We do our best to make the text legible and the pictures viewable. However, the end result depends largely on the quality of instructions the manufacturer provides.

Therefore, you will find that some instructions are not of the highest quality. Sometimes text is hard to read and pictures are not easy to see. At times you will find the overall look of the instructions to be less than professional. However, we feel it is better to provide what we have rather than provide nothing at all.

To the best of our knowledge the instructions and application information contained in the instructions is accurate. However, Dennis Kirk assumes no liability related to any errors that may be contained in the copy of the manufacturer's instructions we provide. Buyers are solely responsible to insure that product use is consistent with their application.

If you have any questions please contact us at customerservice@denniskirk.com or 800-969-7501 so we can further assist you regarding additional product information or any other business related questions.

Thank you for doing business with Dennis Kirk.

MBQUART[®]
MUSIC. DEFINED.

GMR-LCD
AM/FM/USB/Bluetooth[®]
Multimedia Controller
for Off-Road and Marine

DENNIS
KIRK
COPY

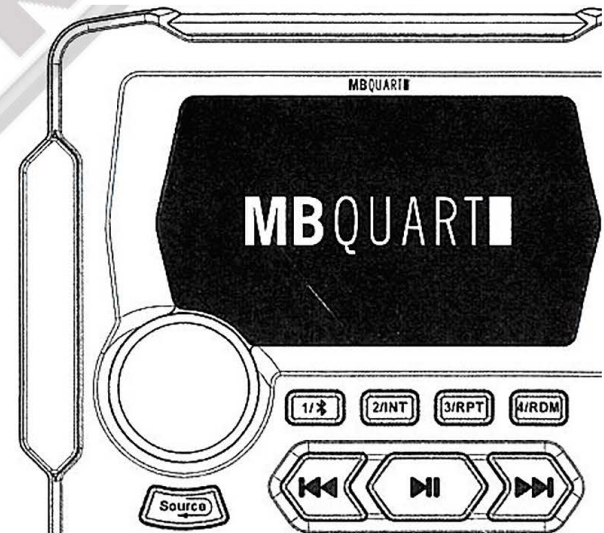

**Operator's Guide and
Installation Instructions**

Congratulations for choosing the AM/FM/USB Bluetooth Multimedia Controller by MB Quart. For more detailed information about the product, please visit MBQuart.com



Always consider consulting a professional audio installation technician before installing any mobile audio components. Be careful and take your time. Do not let wires make contact with metal edges, sources of moisture or hot engine components.

General Information

Powersports and Marine Multimedia Source Unit

AM/FM, USB, Bluetooth® and AUX sources
 160 Watts Peak Power with Pre Amplifier Line Outputs
 Marine Certified to IPX67 for Water and Dust Intrusion

Auxiliary A/V Sources

Quick Connect Bluetooth Audio
 USB Audio Input w/Charging
 Auxiliary RCA Stereo Preamp Input

AM / FM

USA Frequency: FM87.5 – 107.9MHz / AM530-1710kHz
 Europe Frequency: FM87.5 – 108MHz / AM522 – 1620kHz
 Intermediate AM/FM Frequency: 10.7MHz
 Intermediate Frequency Rejection: 50dB
 Noise Limit Sensitivity: >5uV

USB / AUX / Bluetooth Audio Section

RCA S/N: >81dB Powered Outputs S/N: >74dB
 USB A/D Conversion: 16bit Frequency Response: 20Hz – 20KHz

Audio Section & Other Features

Power Output: 4 x 40 Watts Max (160 Watts Peak Power)
 Load Impedance: 4 - 8 Ohms / Channel
 Preamp Output Voltage: 4 volts

Installation Specifications

4" / 100mm - Total Mounting Depth Required (Incl. U-Bracket)
 3" / 76.2mm - Cut Out Diameter

Wiring and Connections

Water Tight Plug Face Shown (Wires to Connect Exit Rear)

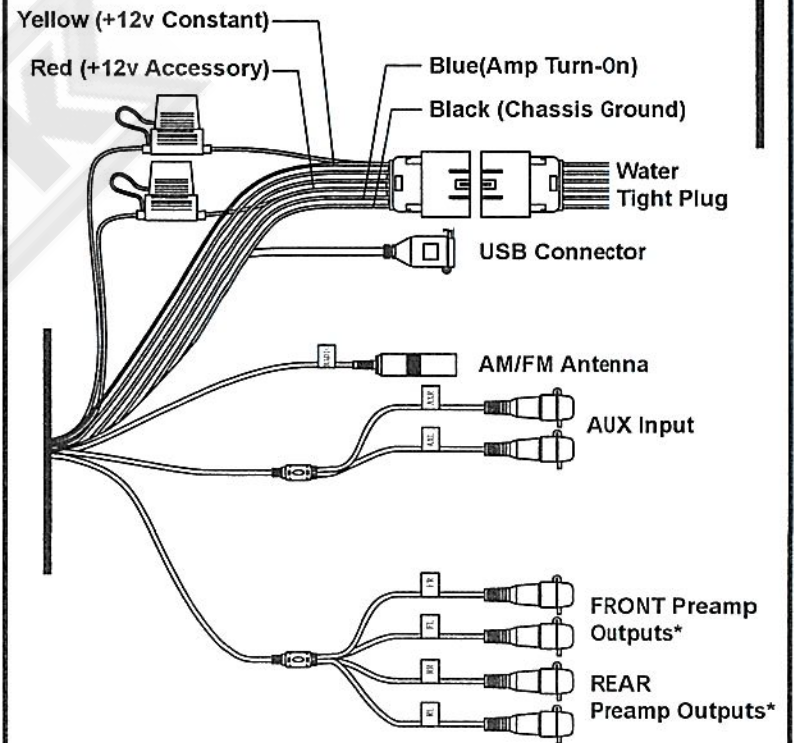
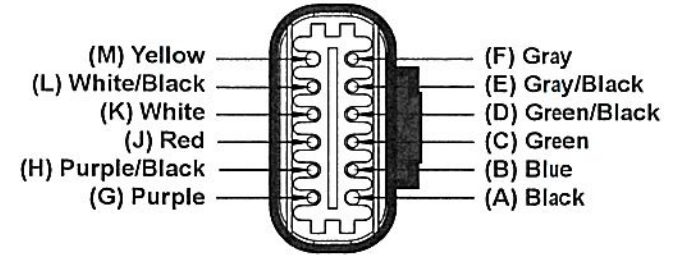

Note: See wiring chart on next page for connection tips, wire colors and functions.

Wiring and Connections

- We recommend wire-to-wire connections such as power, ground and speaker wiring are soldered and protected with either heat shrink tubing or high quality electrical tape.
- The main (yellow) power wire should be connected to a source with at least 10 amps of additional current capability to support the unit.

Wire Color	Location	Function
Black	Plug Pin A	Negative Chassis Ground (-)
Blue	Plug Pin B	Amp Turn-On (+12v Output)
Green	Plug Pin C	Left Rear Speaker (+)
Green/Black	Plug Pin D	Left Rear Speaker (-)
Gray/Black	Plug Pin E	Right Front Speaker (+)
Gray	Plug Pin F	Right Front Speaker (-)
Purple	Plug Pin G	Right Rear Speaker (+)
Purple/Black	Plug Pin H	Right Rear Speaker (-)
Red	Plug Pin J	+12 volt Accessory
White	Plug Pin K	Left Front Speaker (+)
White/Black	Plug Pin L	Left Front Speaker (-)
Yellow	Plug Pin M	+12 volt Constant (>10a)

Preamp Level Audio Connections

- Front and rear RCA preamp outputs are labeled as such. These are intended to be connected to external amplifiers, not included.

Rear Mounting Instructions

- Check for appropriate mounting depth and mechanical or electrical obstacles behind the mounting panel BEFORE any cutting. Including the "U"-shaped aluminum mounting bracket, at least 4" (100mm) depth is required.
- Using a 3" hole saw or air saw, cut a 3" (76.2mm) diameter hole in the mounting panel. Use a file or sandpaper to smooth out any rough edges after the cut is complete.
- Thread the two supplied bolts into the back of the multimedia controller using a 9/32" nut driver or deep socket. The threaded holes are located just above the wiring harness in the heatsink.

Rear Mounting Instructions (Continued)

- Thread the two supplied bolts into the back of the multimedia controller using a 9/32" nut driver or deep socket. The threaded holes are located just above the wiring harness in the heatsink.
- Thread two of the supplied 9/32" mounting nuts upside down on the bolts. The flat surface of the nut will sit flush with the inside of the mounting bracket to allow spacing (if needed).
- Insert the source unit through the mounting hole opening. Be sure to allow enough depth for wiring to be securely tied up once the installation is complete.
- Attach the aluminum mounting bracket to gauge the sizing and that it will fit over the supplied threaded bolts. If necessary, use pliers to break away the marked sections until the bracket fits snugly against the mounting panel. Be sure the bracket clears the wiring on the back of the unit without rubbing or heavily bending the wires.
- Attach the remaining supplied 9/32" mounting nuts on the threaded bolts to secure the mounting bracket.

Installation Opening & Depths

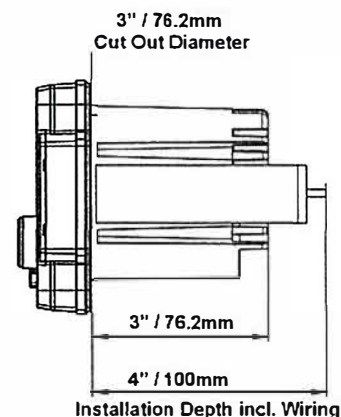

Mounting Bracket Details

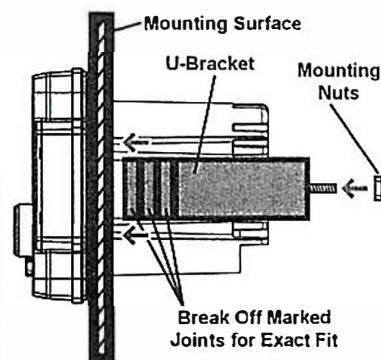

Front Mounting Instructions

- Check for appropriate mounting depth and mechanical or electrical obstacles behind the mounting panel **BEFORE** any cutting. At least 3.75" (95.25mm) depth is required.
- Using a 3" hole saw or air saw, cut a 3" (76.2mm) diameter hole in the mounting panel. Use a file or sandpaper to smooth out any rough edges after the cut is complete.
- Remove the snap-in covers on the front panel hiding the mounting holes. Use a small flat head screw driver in the two small indents on each cover to gently pry open.
- Insert the source unit through the mounting hole opening. Be sure to allow enough depth for wiring to be securely tied up once the installation is complete. Ensure the source unit is level.
- Mark four (4) holes using an awl, straight pick tool or 1/16" (1.5mm) drill bit to make the markings. **DO NOT DRILL THROUGH WITH THE SOURCE UNIT IN PLACE.**
- Remove the source unit and gently drill the four (4) marked locations for mounting holes using a drill with a 1/16" (1.5mm) drill bit.
- Re-insert the source unit in the opening. Gently install the four supplied screws in each of the mounting holes with a handheld screwdriver. Do not use drills or battery-powered screw guns for this step.
- Replace the snap-in covers on the source unit's front panel.

Installation Opening & Depths

3" / 76.2mm Cut Out Diameter

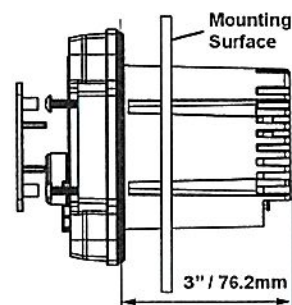

3.75" / 95.25mm Installation Depth incl. Wiring

Front Mounting Details

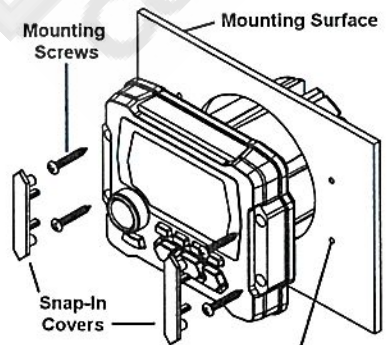

Drill (4) 1/16" / 1.5mm Holes

Front Panel Controls

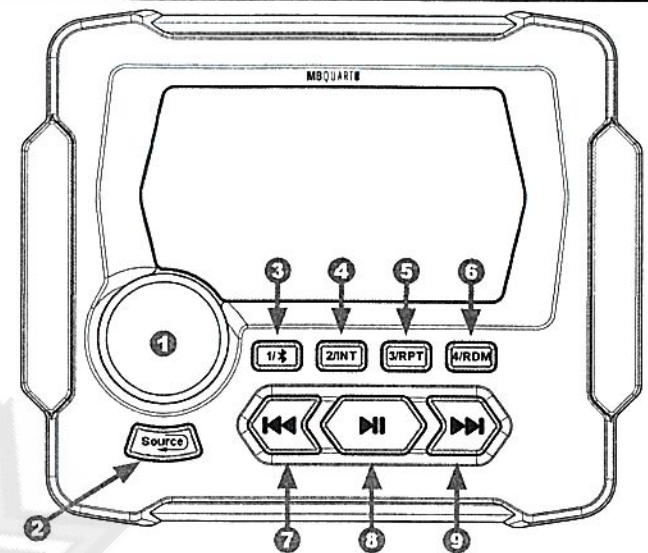

1 POWER/Selector and Volume Knob

- Press the POWER/Selector Knob to power on the unit.
- Rotate the POWER/Selector Knob to view sources when source selection menu wheel is displayed. To select a source, press and release the POWER/Selector Knob.
- Rotate the POWER/Selector and Volume Knob to increase or decrease sound levels once a source is selected.
- Press and hold the POWER/Selector Knob for 5 seconds to power the unit off.

2 SOURCE Button

- Press the SOURCE button to display the source selection menu wheel. See next page for details. Also functions as the "back" button in a SETTINGS menu.

3 1/3 Button

- Preset 1 for AM/FM, pairing on Bluetooth source.

4 2/INT Button

- Preset 2 for AM/FM. No other function.

5 3/RPT Button

- Preset 3 for AM/FM. Repeat play (1 or all) on USB source.

6 4/RDM Button

- Preset 4 for AM/FM. Random play (Shuffle) on USB source

7 Scan Down for AM/FM or Track Back for USB/Bluetooth source.

8 Mute for AM/FM and AUX or Play/Pause for USB/Bluetooth source.

9 Scan Up for AM/FM or Track Up for USB/Bluetooth source.

Source Selection



Press SOURCE Button to display source selection menu.

Note: On USB source, the unit "auto selects" USB input whenever a device is plugged in. All other sources must be selected by the user. When selecting Bluetooth, a device must be first paired to playback audio.

AM/FM Configuration

Several configurable AM/FM radio parameters are available.

- Select between AM or FM on the Source Menu wheel. Each has its own menu.
- Once the chosen source is selected, press and hold the SOURCE button for 2 seconds. The AM or FM menu will appear (whichever source is selected).



Press and Hold
(2 seconds).

- Use the source menu selector knob to scroll to the chosen parameter. Press the center of the knob to either adjust the parameter directly, or enter the sub-menu and adjust by scrolling and pressing the center of the knob again.
- A complete list of each parameter and its variables is listed on the following page.
- Use the SOURCE button to go back to the previous screen.
- Continue using the SOURCE button to exit AM or FM setup.

AM/FM Configuration

Settings Choices for AM

- **PRESETS** - This function shows stored AM presets 1-4 on AM1 or AM2.
- **SAVE PRESETS** - This function stores AM presets in spaces 1-6. Only presets 1-4 have front panel quick access buttons.
- **AM BAND** - This function selects AM1 or AM2 bands. Choose and store and recall AM presets. 4 on AM1, 4 on AM2.
- **AUTO STORE** - Automatically searches and stores presets in memory.

Settings Choices for FM

- **PRESETS** - This function shows stored FM presets 1-4 on FM1, FM2 or FM3.
- **SAVE PRESETS** - This function stores FM presets in spaces 1-4. Only presets 1-4 have front panel quick access buttons.
- **FM BAND** - This function selects between FM1, FM2 or FM3 bands. Choose and store and recall FM presets. 4 each on FM1, FM2 & FM3.
- **AUTO STORE** - Automatically searches and stores presets in memory.

AM/FM

Once setup is complete, select between AM or FM icons on the Source Menu wheel or simply press the SOURCE button to back up to the source screen showing the current AM or FM frequency.

- Press the **◀◀** or **▶▶** buttons less than 1 second to manually seek radio stations one frequency at a time.
- Press the **◀◀** or **▶▶** buttons more than 1 second to automatically seek the next / previous radio stations with strong reception.
- Press and hold buttons 1-4 below the screen to store a preset. Four AM and four FM preset locations are available on the front panel.
- Press the center **▶||** button to mute the AM or FM source. Press **▶||** again to unmute or simply rotate the volume control knob.

AM/FM (Continued)



FM Screen Example



AM Screen Example

Bluetooth Pairing

The multimedia controller supports Bluetooth A2DP for wireless music streaming from a mobile device, such as a smartphone or streaming music source component. The unit does not support the HF (Hands-Free) or PBAP (Phone Book Access for Contacts) profiles. No calling features are available, only Bluetooth music streaming.

Pairing a Bluetooth device:



BT Pair Screen

- Ensure the multimedia controller is on and Bluetooth is the selected source. The screen will show "BT Disconnected!"
- Ensure the Bluetooth functionality on the mobile device is enabled and supports A2DP audio streaming.
- Scan for **GMR-5** in the Bluetooth list on the mobile device.
- Select **GMR-5** and the connection will then be made automatically.
- A "BLUETOOTH Loading" screen will appear briefly as the mobile device's song info and album art are transferred to the multimedia source unit.

See next page if a pin code is required to pair.

Bluetooth Pairing & Operation

If a PIN Code is Required:

- Some Bluetooth devices require inputting a pass code for connection. Please input code "0000" and the connection will be made automatically.

Automatically Connecting:

- Once the multimedia controller has made a connection with the Bluetooth mobile device for the first time, the unit can then connect to the Bluetooth mobile device automatically within a valid range.

Manually Disconnecting:

- To disconnect temporarily, for example to take a phone call, press and hold the **1/2** button for 3 seconds and the mobile device will disconnect. If no phone call is in progress, it will automatically reconnect to the unit in about 15 seconds.
- To disconnect and allow another user to connect, use the mobile device to forget the "GMR-5" connection entirely.

Once a Bluetooth device is paired and recognized:

- Be sure the multimedia controller has the Bluetooth source selected. The multimedia controller should automatically begin playing where the mobile device last left off of the music player's song or playlist.
- If the unit does not automatically begin playing, press the center **▶▶** button to play the Bluetooth source. The play (**▶**) symbol will display when music is playing. The time elapsed in the song play is also displayed on the screen.
- Press **▶▶** again to mute and pause the song. The pause (**||**) symbol will display when music is paused.
- Press **▶▶** again to resume playback or simply rotate the volume control knob.
- Press the **◀◀** or **▶▶** buttons more than 1 second to manually fast forward or rewind within a song. Press the same button again to stop the fast forward or rewind function.
- Press the **◀◀** or **▶▶** buttons less than 1 second to automatically fast forward or rewind the next / previous song.

Note: Functions such as "Repeat" and "Random Play" (a.k.a "Shuffle") must be controlled at the mobile device directly.

See the USB Input section for smartphones connected via USB and the capability for Repeat and Random (Shuffle) functionality.

USB Input

The multimedia controller supports MP3, WMA, and WAV audio files with a USB thumb drive connected. Additionally, M4A or Apple Lossless file types are supported if the user connects an iPhone® using iTunes as the music player.

Most smartphones with a USB-based charging connector and USB thumb drives easily connect to the multimedia controller. Many smartphones include album art through the phone's music player. Some USB thumb drive files may not include album art, only song information.



To begin, connect a USB device and the unit reads the music files automatically. 32GB max USB thumb drive.

- A "USB Loading" screen appears as the device's song info. Smartphones take a few seconds longer than a USB thumb drive.
- If the unit does not automatically begin playing, press the center ►|| button to play the USB source. Press ►|| again to mute and pause the song. Press ►|| again to resume playback or simply rotate the volume control knob.
- Press the ◀◀ or ▶▶ buttons more than 1 second to manually fast forward or rewind within a song. Press the same button again to stop the fast forward or rewind function.
- Press the ◀◀ or ▶▶ buttons less than 1 second to automatically fast forward or rewind the next / previous song.

Read about Repeat (RPT) and Random (RDM) modes and controls on the following page. Smartphones behave differently than USB drives.

USB Thumb Drive Screen:

Music Note Icon
Song Title and Artist Info
Time Elapsed in Song Play
Play or Pause Status
Status of RPT (even when OFF)
Status of RDM (only when ON)

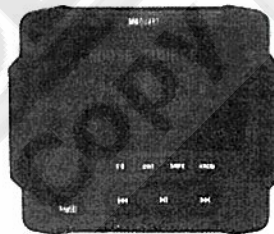

USB Thumb Drive Screen

USB Smartphone Screen:

Music Note Icon
Song Title and Artist Info
Time Elapsed in Song Play
Play or Pause Status
Status of RPT & RDM (only when ON)



USB Smartphone Screen

USB RPT and RDM Functionality

The multimedia controller has two modes of making a USB-connected music library more interesting with Repeat (RPT) and Random (RDM) functions. Random play is also called "Shuffle" on some mobile devices.

USB Thumb Drive RPT and RDM

With a thumb drive connected to the USB input, users see an icon on the right side of the screen (centered) that indicates the status of the RPT mode. The default status is off. RDM (Shuffle) default status is off and no icon shows until it is engaged.

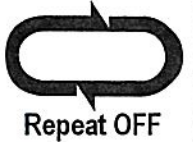

- The RPT sequence of button presses is as follows:



- The RDM (Shuffle) sequence of button presses is as follows:



USB Smartphone RPT and RDM

With a smartphone connected to the USB input, users see no icons. When a function is active, the screen displays a text message of the mode above 3/RPT button. The default status of RPT and RDM (Shuffle) are both off.

- The RPT sequence of button presses is as follows:



- The RDM (Shuffle) sequence of button presses is as follows:



Auxiliary (AUX) Input



After selecting **AUX** in the source menu, begin playing the music on the auxiliary device. Turn its volume up. Main volume can then be controlled via the unit along with muting audio.

Select the **AUX** icon in the menu.

SETTINGS Menu

To access **SETTINGS**, press Selector/Volume knob in any source. The "SETTINGS" menu appears immediately.

Press the Selector/Volume knob in any source, or select the "Gear" icon.

- Use the Selector/Volume knob to navigate the menu items. When the gray highlighted bar is on the chosen parameter, press the Selector/Volume knob to go into that menu (or sub-menu). This is similar to an "Enter" command. Use the Selector/Volume knob to navigate parameters within the menu. Once the parameter is set, use the **SOURCE** button to go back to the previous screen.

BASS Level

- Adjust the bass from -7 to +7. Default setting is "0." Center frequency is 100Hz.

TREBLE Level

- Adjust the treble range from -7 to +7. Default setting is "0." Center frequency is 10KHz.

BALANCE Control

- Adjust the balance from L10 - 00 - R10

SETTINGS Menu (Continued)

- Use the **SOURCE** button to close the balance screen when complete and return to the main menu.

FADER Control

- Adjust the fader from R - 10 - 00 - F10

Audio System Design Ideas

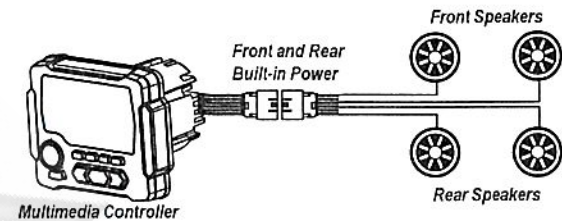

4-Speaker System using Built-in Power

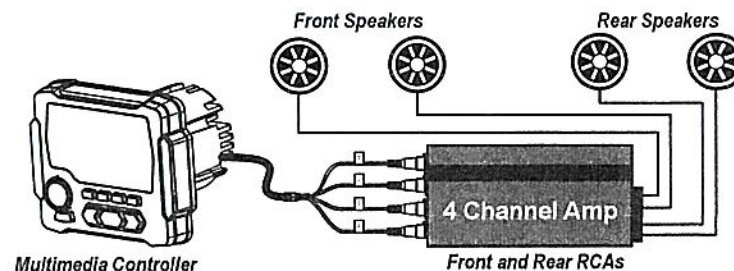

Amplified System

