



General Features

- * Die Cast Basket with Black Textured Finish
- * Kevlar Fiber Enhanced Non-Pressed Paper Cone with Textured Paint Finish
- * EROM Foam Surround with Red Stitching
- * 3.0" 4-Layer Hi-Temp Voice Coil
- * Fiberglass Woven Dust Cap
- * Enhanced Cooling T-yoke Design with Black Anodized Finish
- * Double Stacked 180oz High Energy Magnets
- * Double Black Poly Cotton Spiders with Mirror Image Layout
- * Customized Rubber Gasket and Magnet Boot
- * 10 Gauge Power Cable with Direct Lead Connection
- * Dual 4 Ohm Impedance & Dual 2 Ohm Impedance

Specifications

Mechanical		KILOX 104	KILOX 122	KILOX 124	KILOX 154				
Fs	Hz	40.2	37.2	36.4	36.0				
Qms		4.54	5.11	4.2	4.68				
Vas	liters	10.2	22.2	23.5	46.9				
Cms	mm/N	0.07	0.06	0.07	0.06				
Mms	g	229.2	286.2	287.9	341.0				
Rms	kg/s	12.9	13.1	15.7	16.5				
Watts Rms	W	1000	1000	1000	1000				
Peak Power	W	2000	2000	2000	2000				
Xmax	mm	14	14	14	14				
Xmech	mm	40	40	40	40				
Dia.	mm	205	255	255	322				
Sd	sq.m	0.033	0.051	0.051	0.081				
Vd	liters	4.23	5.35	5.35	7.45				
Electrical Parameters		Parallel	Series	Parallel	Series	Parallel	Series	Paralle	Series
Qes		0.64	0.67	0.55	0.60	0.67	0.66	0.71	0.77
Re	Ohms	1.8	7.2	0.9	3.6	1.8	7.2	1.8	7.2
Le	mH	0.94	3.21	0.60	2.44	0.93	3.18	0.98	3.25
BL	Tm	12.8	25.1	10.4	20.0	13.3	26.7	13.8	26.9
Pe	Watts	1000	1000	1000	1000	1000	1000	1000	1000
Electromechanical		Parallel	Series	Parallel	Series	Parallel	Series	Parallel	Series
Qts		0.56	0.58	0.50	0.54	0.57	0.57	0.62	0.66
no	%	0.10	0.10	0.21	0.18	0.16	0.16	0.31	0.28
1-W-SPL	dB	83.3	83.1	85.1	84.6	84.1	84.0	86.9	86.4
2.8V SPL	dB	86.5	86.0	87.3	87.0	86.8	86.7	88.7	88.3

1000
RMS WATTS

2000
PEAK WATTS



RoHS (E8)



P.O. Box 252004 Los Angeles, CA 90025 U.S.A.
WWW.MASSIVEAUDIO.COM



KILOX 104

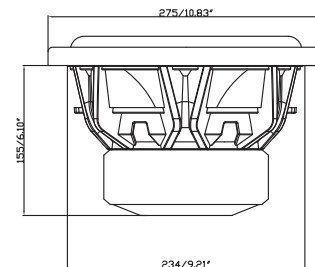

KILOX 124/ KILOX 122

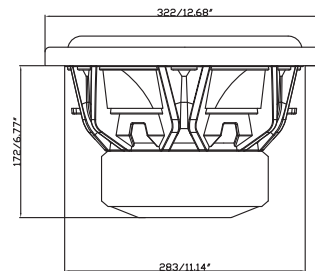

KILOX 154

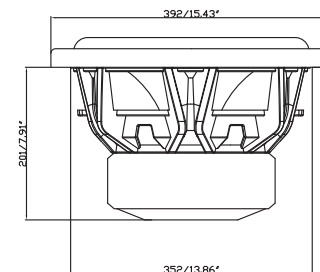



KILOX

For More Customized Box Volume Specifications
Please Visit www.massiveaudio.com

Dimensions	KILOX 104	KILOX 122	KILOX 124	KILOX 154
Mounting Depth (A)	6.10"	6.77"	6.77"	7.91"
Mounting Diameter (B)	10.83"	12.68"	12.68"	15.43"
Mounting Cut Diameter (C)	9.21"	11.14"	11.14"	13.86"
Shipping Weight (lb)	19.4 Lbs	20.3 Lbs	20.3 Lbs	21.6 Lbs
Displacement (ft3)	0.058	0.087	0.087	0.158

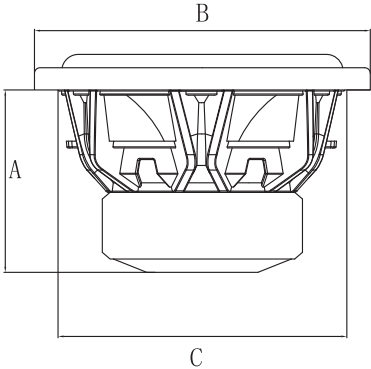

	KILOX 104		KILOX 122		KILOX 124		KILOX 154	
Single Sealed	Small	Large	Small	Large	Small	Large	Small	Large
Volume (cub. ft)	0.72	0.95	1.11	1.43	1.11	1.43	2	2.61
Internal (Width x Height x Depth) in.	1.2x10.8x10.4	12.4x11.2x11.9	13.1x12.7x11.5	14.3x13.1x13.2	13.1x12.7x11.5	14.3x13.1x13.2	16.2x15.8x13.4	17.4x16.6x15.6
F3 Hz	34	33	34	33	34	33	40	39
Qtc	0.707	0.707	0.707	0.707	0.707	0.707	0.707	0.707
Single Ported	Small	Large	Small	Large	Small	Large	Small	Large
Volume (cub. ft)	0.8	1.07	1.21	1.6	1.21	1.6	2.15	2.77
Internal (Width x Height x Depth) in.	12.4x10.8x10.4	13.1x11.6x12.2	14.3x12.7x11.5	15.1x13.5x13.5	14.3x12.7x11.5	15.1x13.5x13.5	17x16.2x13.4	17.8x17x15.8
Fb Hz	45	40	40	35	40	35	40	35
F3 Hz								
Port Round (D XL)	5.9x8	6.2x7.7	6.4x8.9	6.9x8.8	6.4x8.9	6.9x8.8	6.8x5.9	7.3x6.5
Port Area sq. in.	27	31	32	38	32	38	36	42
Dual Ported	Small	Large	Small	Large	Small	Large	Small	Large
Volume (cub. ft)	1.4	1.83	2.15	2.77	2.15	2.77	3.9	5.04
Internal (Width x Height x Depth) in.	21.6x10.8x10.4	22.4x11.6x12.2	25.4x12.7x11.5	26.2x13.5x13.5	25.4x12.7x11.5	26.2x13.5x13.5	30.9x16.2x13.4	31.7x17.4x15.8
Port (1) Sq. area in.	24.5	27.8	29	33	29	33	33	39
Port Length	9.5	9.2	10	10	10	10	7	7
F3 Hz	45	40	40	35	40	35	40	35

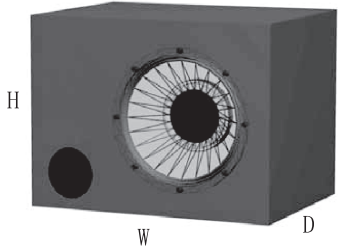

The port may have to be placed along the back wall facing the side. Place a brace between the subs about 4 inches wide on the inside.
Make sure that the end of the port "inside the box" is at least the same distance away from the back wall as the port diameter. If port is 4" round = 4.5" from wall

Attention:

- *Box sizes account for driver and port displacement
- *For higher SPL shortening the port length 3 in. will raise frequency +/- 5 Hz
- *Box specifications are internal. For external dimensions add the width of the box material to these dimensions.
- *A square port (slot) is preferred in high power applications for less vent noise.
- *Port area = width x height
- *For dual speaker, double the volume and the number of ports but keep the same length.
- *If possible use a divided box.
- *If a common chamber box is to be used, internal bracing is highly recommended
- *Please contact Massive Audio for custom applications.

