

POWER ACOUSTIK

RAZOR

Class D Full Range & Monoblock Amplifiers

RZ4-1200D

RZ1-1500D

RZ5-2500D

RZ4-2000D

RZ1-2300D

RZ4-3000D

RZ1-3500D



Features RZ4-1200D RZ4-2000D RZ4-3000D

- Compact 4.75" Chassis Design for Installation Versatility
- MOSFET Power Supply w/ Audiophile Grade IR™ Transistors
- Military Grade SMT PCB Maintains Dynamic Performance
- 2-ohm Stereo & 4-ohm Bridged Full Range Operation
- Direct Short, Thermal, & Overload Circuits Protect Amplifier
- 200mv-6V Low Level RCA Balanced Inputs
- High Level Input w/ Signal Sense Auto Turn-on
- Variable 12dB High Pass & Low Pass Crossovers
- 8ga Direct Connect Speaker Wire Terminals
- 8ga Direct Connect Power/Ground Wire Terminals
- Selectable 80Hz 12dB High Pass & Low Pass Crossover (1200D & 2000D)
- Variable 35-250Hz 12dB High Pass & Low Pass Crossover (3000D)

RZ4-1200D RZ4-2000D

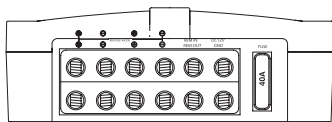
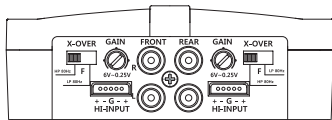

RZ4-3000D

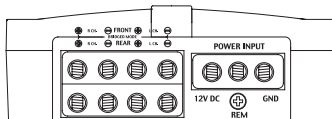
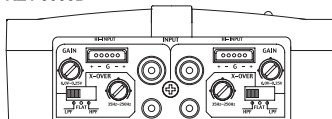

Features RZ5-2500D

- Compact 4.75" Chassis Design for Installation Versatility
- MOSFET Power Supply w/ Audiophile Grade IRTM Transistors
- Military Grade SMT PCB Maintains Dynamic Performance
- 2-ohm Stereo & 4-ohm Bridged Full Range Operation
- Direct Short, Thermal, & Overload Circuits Protect Amplifier
- 200mv-12V Low Level RCA Balanced Inputs
- High Level Input w/ Signal Sense Auto Turn-on
- Dash Mount Remote Gain Control Included
- Variable 12dB High Pass & Low Pass Crossovers
- 8ga Direct Connect Speaker Wire Terminals
- 8ga Direct Connect Power/Ground Wire Terminals
- Variable 35-250Hz 12dB High Pass Crossover (ch. 1-4)
- Variable 35-250Hz 12dB Low Pass Crossover (ch. 5)
- Variable 0-12dB 50Hz Bass Boost (ch. 5)

RZ5-2500D

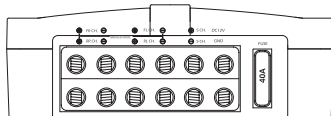
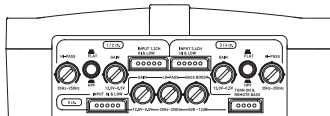

Features **RZ1-1500D RZ1-2300D RZ1-3500D**

- Compact 4.75" Chassis Design for Installation Versatility
- MOSFET Power Supply w/ Audiophile Grade IR™ Transistors
- Military Grade SMT PCB Maintains Dynamic Performance
- 2-Ohm Minimum Impedance Stable Class D Amplifier (1500D & 2300D)
- 1-Ohm Minimum Impedance Stable Class D Amplifier (3500D)
- Direct Short, Thermal, & Overload Circuits Protect Amplifier
- 200mv-6V Low Level RCA Balanced Inputs
- High Level Input w/ Signal Sense Auto Turn-on
- Dash Mount Remote Gain Control Included
- Variable 12dB Low Pass & Subsonic Crossovers
- 8ga Direct Connect Speaker Wire Terminals
- 8ga Direct Connect Power/Ground Wire Terminals
- Variable 35Hz-250Hz 12dB Low Pass Crossover
- Variable 10Hz-50Hz 12dB Subsonic Crossover
- Variable 0-12dB 45Hz Subwoofer Bass Boost

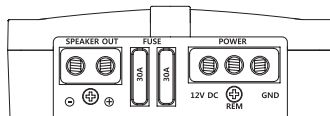
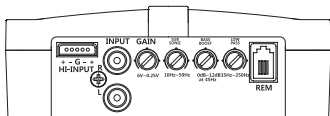

Specification

POWER RATINGS	RZ4-1200D	RZ4-2000D	RZ4-3000D
RMS Power 4 Ω, 14.4V	100w x 4	190w x 4	285w x 4
RMS Power 2 Ω, 14.4V	150w x 4	250w x 4	375w x 4
RMS Power 4 Ω Bridged, 14.4V	300w x 2	500w x 2	750w x 2
Dimensions (4.75"w x 1.5"h)	9"	11"	12.25"

POWER RATINGS	RZ5-2500D	RZ1-1500D	RZ1-2300D	RZ1-3500D
RMS Power 4 Ω, 14.4V	100w x 4ch + 400w	600w	900w	900w
RMS Power 2 Ω, 14.4V	150w x 4ch + 600w	900w	1,400w	1,400w
RMS Power 1 Ω, 14.4V	-	-	-	2,100w
RMS Power 4 Ω Bridged, 14.4V	300w x 2ch + 600w	-	-	-
Dimensions (4.75"w x 1.5"h)	12.25"	10"	11"	12.25"

Power Connections

It is important to have good quality power and ground connections. Remember, to complete an electrical circuit, the ground connection is just as important as the positive power connection. Before any power connections are made, disconnect the ground cable of the battery. Use 8 gauge or larger automotive grade wire if the distance from the battery to the amp is excessive. Avoid sharp or rough edges as a safeguard against short circuiting and potential fire hazards.

GND = Connect the proper gauge ground wire to the amplifier GND terminal. Locate the position on the chassis of the car where the amplifier will be grounded. Use solder or a crimped ring terminal to connect the ground wire. Pre-drill the prepped chassis to bolt the ground ring terminal with a nut, bolt, and lock washer. Insulate the metal and the connector with paint or silicone to prevent rust and oxidation. Silicone also works great to prevent nuts and bolts from working loose in harsh environments of an automobile. Upon completion of the ground connection, grab the wire and connector to confirm the connection is solid. To prevent engine noise, it is recommended to ground the head unit and other electronic audio devices to the same location.

REM = Connect the remote wire (power antenna output) from the head unit to the REM terminal. If the head unit is not equipped with a remote/antenna output, locate a wire that is controlled by the accessory position of the key. It is important to have the amplifier turn off with the radio or key. If the amplifier remains on, the battery will drain.

12V = Connect the proper gauge power wire to the B+ terminal. Trace the power wire through the car to the in-line fuse or circuit breaker that is no more than 18" from the battery. Remember, the in-line fuse or circuit breaker protects the car in the event of short circuit. Connect the in-line fuse or circuit breaker to the battery, but do not install the fuse or activate the circuit breaker yet.

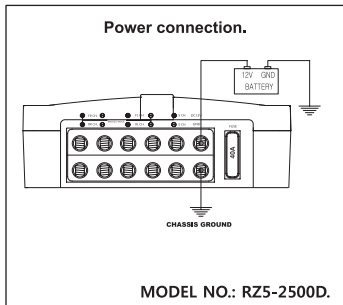
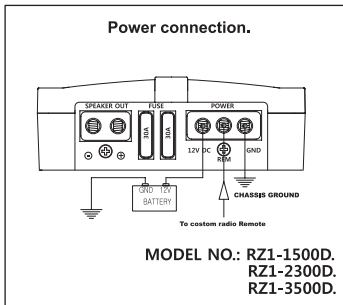
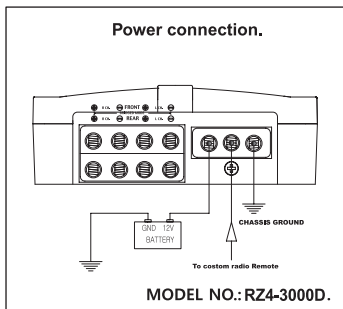
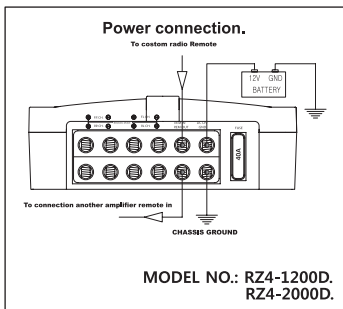

High Level input connections

The high level inputs are for use with speaker level wiring. Most factory source units do not have RCA outputs. Use this connection if your source unit does not have RCA outputs.

CAUTION: Never use the high and low level inputs at the same time!

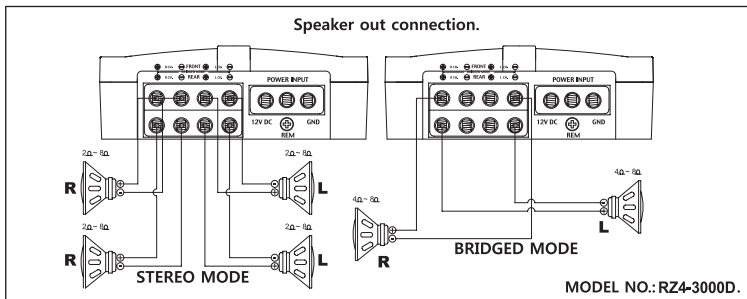
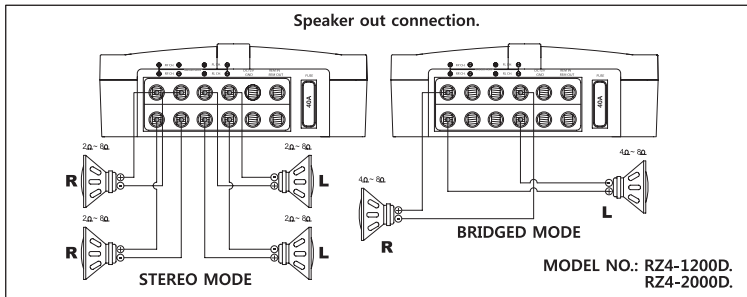

Speaker out connection.

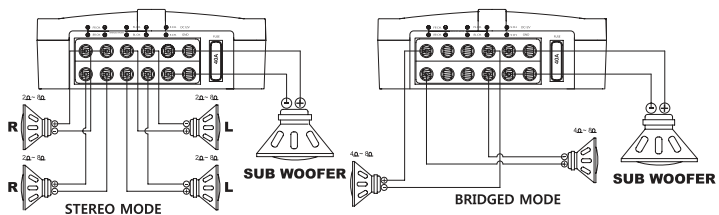

MODEL NO.: RZ5-2500D.

Speaker out connection.

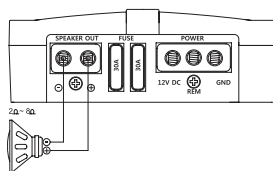

MODEL NO.: RZ1-1500D.
RZ1-2300D.
RZ1-3500D.

RAZOR PRE-AMP FEATURES

1. Remote Level Control Connection

Connect the remote level control to this terminal. The remote level control allows adjustment of the subwoofer level from a remote location in the vehicle.

2. Low Pass Crossover

Adjust the frequency setting of the low pass crossover. The frequency range is 35Hz-250Hz. Frequencies higher than the setting will be filtered out of the audio signal.

3. Subsonic Crossover

Adjust the frequency setting of the subsonic crossover. The frequency range is 10Hz-50Hz. Frequencies lower than the setting will be filtered out of the audio signal.

4. Power & Protection Indicator LED

When the amplifier is on and in proper working condition, the green LED will illuminate. Refer to the Troubleshooting Guide for possible solutions if the amplifier will not power on. If the amplifier activates its protection mode, the red LED will illuminate. Refer to the Troubleshooting Guide for possible solutions if the amplifier activates its protection mode.

5. Level Sensitivity

Adjust the amplifiers pre-amp sensitivity level. The minimum sensitivity level is 250mv, while the maximum level is 6V.

Note : Remote trigger input power must be connected well tight and firmly on the 3.5 pie port, Amplifier won't be able to turn on if its loosen or not connected.

6. RCA Audio Input Connection

Using high quality shielded stereo RCA cables, connect the source signal to the amplifier RCA inputs.

7. High Level Input

Connect the speaker outputs from the head unit to the high level input if RCA outputs are not available. NEVER use high level and RCA inputs at the same time.

8. Bass Boost

Adjust the amplifiers 45Hz Bass Boost level up to 12dB.

9. Crossover Selection Switch

Choose an 80Hz fixed frequency high pass crossover, 80Hz fixed frequency low pass crossover, or full range operation.

10. Variable High Pass Filter 35Hz~250Hz

For use as a dedicated mid high range channel, set filter switch to " HIGH PASS". The Input circuit filters out all frequencies below 35Hz~250Hz

11. The 5 channel amplifier will be activated remote trigger input with bass control unit on the 3.5 pie port same time in the mode. It requires connect remote trigger input on power input connector section to turn on the amplifier if user won't need to connect the bass control unit

4 CH. FUNCTIONS.

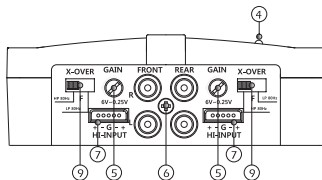

MODEL NO.: RZ4-1200D.
RZ4-2000D.

4 CH. FUNCTIONS.

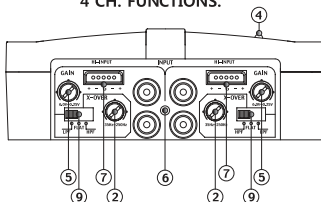

MODEL NO.: RZ4-3000D.

5 CH. FUNCTIONS.

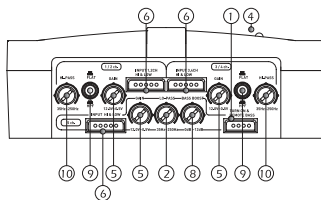

MODEL NO.: RZ5-2500D.

MONO BLOCK FUNCTIONS.

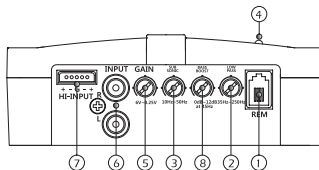

MODEL NO.: RZ1-1500D.
RZ1-2300D.
RZ1-3500D.

Mounting Your Razor

Choosing the best mounting location for your Razor amplifier is crucial. The amplifier should be mounted to any wood, metal, or carpeted surface. The heatsink can be mounted directly to the chassis of the car, or isolated for best performance. It needs proper ventilation, so avoid mounting the amp under seats, in the engine bay, or any other area that moisture might accumulate. Be sure the mounting screws do not penetrate the fuel tank, brake lines, or any other crucial fluid lines. Never mount the amplifier to a subwoofer enclosure, as excessive vibrations can cause damage.

Warning

Power Acoustik highly recommends that an in-line fuse or circuit breaker be installed within 18" of the battery. Although your Razor amplifier has adequate internal protection, it is possible a damaged wire between the component and the battery may result in a fire. The in-line fuse or circuit breaker should be installed in a location that is easy to access, and all wiring should be routed safely, following the below suggestions:

- Avoid placing wires near hot or moving objects
- Always use wire grommets when routing wire through the firewall or any other metal surfaces
- Avoid the potential for damaged wires by routing all wires away from moving hinges, seats, brake & gas pedals, hood and trunk hinges, etc.

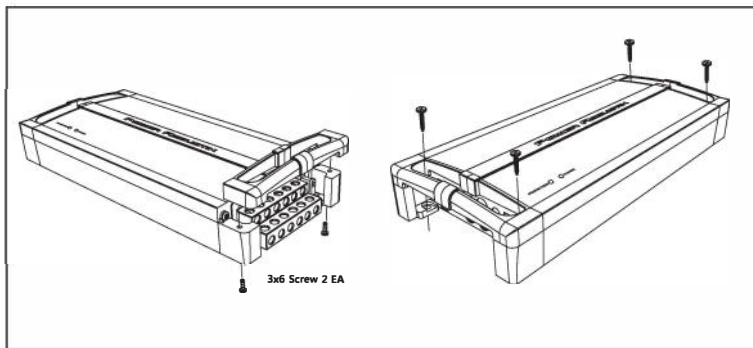

Setting the gains:

It is a fact that very few people, including professional installers, know how to set gains correctly. Failure to do so yields higher distortion, a higher noise floor which decreases dynamic headroom, less than optimum operating conditions for electronic equipment, and higher failure rate for both the electronic equipment and transducers alike.

While most people set this control by ear to how loud they want their music, this is not the intent of this control. The range is from 0.25 volts to 6 volts. The control is meant for matching the output of the source unit's signal voltage. For example, if you have a source unit with low output voltage, you would probably have the control set fairly high, towards the 0.25V range. A lot of head units have 4 volts of output signal voltage which means that your control would be set midway through the range. If you happen to have a line driver (signal booster) that yields 6 volts or more, you will set the gain at the minimum position, towards the 6V range.

In all of these examples, when properly level matched, the amplifier will put out full volume. Setting the control above the proper point may cause damage to the amplifier and speakers, and can result in poor sound quality and overall undesirable results.

Bass Boost control:

The monoblock amplifiers feature a variable Bass Boost control, centered at 45Hz. You can adjust the amount of boost from 0dB to 18dB.

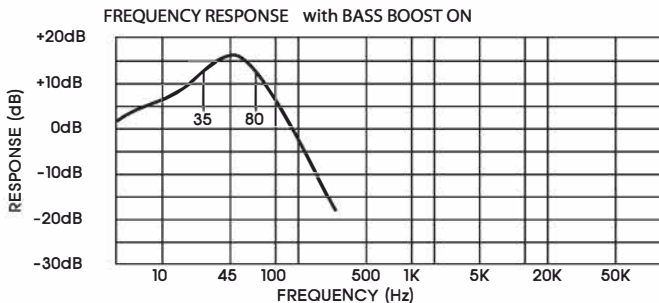

Trouble shooting.

SYMPTOMS	CHECK	REMEDY
NO SOUND	Is the power LED illuminated? (NO)	Check all fuses to amplifier. Be sure Turn-on lead is connected Check signal leads. Check gain control. Check Tuner/Deck volume level. Clean contacts on fuse holders.
	Is the Diagnostic LED illuminated? (YES)	Check for speaker short or amplifier overheating.
AMP NOT SWITCHING ON	No power to power wire	Repair power wire or connections.
	No power to remote wire with receiver on	Check connections to radio.
	Burnt or broken fuse	Replace fuse
NO SOUND, ON ONE CHANNEL	Check Speaker Leads	Inspect for short circuit or an open connection.
	Check Audio Leads	Reverse Left and Right RCA inputs to determine if the problem is occurring before the amp.
AMP TURNING OFF MEDIUM/ HIGH VOLUME	Check Speaker load impedance	Be sure proper speaker load impedance recommendations are observed. (If you use an ohmmeter to check speaker resistance, please remember that DC resistance and AC impedance may not be the same.)
PROTECTION LAMP ON	Shutdown	Turn radio down Wait for AMP to cool
	Speaker wires shorted	Separate speaker wires and insulate

Warning

Investigate the layout of your vehicle before drilling or cutting any holes. Take care when you are working near the gas tank, brake lines, hydraulic lines, and electrical wiring. Do not use the amplifier without securely mounting it, as the amp or vehicle may be damaged in the event of an accident. Do not mount the amplifier where the wire connections are unprotected or are subject to pinching or damage from other vehicle components. The 12V power wire must be fused within 18" of the battery. Ensure the source unit is powered off before making any wiring connections. If you need to replace the fuses, use only the same type and size. Using a fuse of a different type or rating may result in damage to the amplifier or vehicle, which will not be covered under the manufacturer's warranty.

RAZOR

LIMITED 90-DAY CONSUMER WARRANTY LIMITED ONE-YEAR CONSUMER WARRANTY WITH PURCHASE AND INSTALLATION BY A POWER ACOUSTIK AUTHORIZED RETAILER

Power Acoustik promises to the original purchaser, to repair or replace this product with a new or refurbished unit (at Power Acoustik's sole and absolute discretion) should it prove to be defective in workmanship or material under normal use, for a period of one-year from the date of purchase from the Power Acoustik authorized retailer, PROVIDED the product was purchased and installed by a Power Acoustik authorized retailer. During this one-year period, there will be no charge for product repair or replacement, PROVIDED the unit is returned to Power Acoustik, return shipping pre-paid, along with the required proof of installation, the bill of sale or other dated proof of purchase, and the consumer's contact information.

If the unit is installed by anyone other than a Power Acoustik authorized retailer, the warranty period will be 90-days from the date of purchase. This warranty is nontransferable and does not apply to any unit that has been modified or used in a manner contrary to its intended purpose, and does not cover damage to the unit caused by installation or removal of the unit. During this 90-day period, there will be no charge for the repair or replacement PROVIDED the unit is returned to Power Acoustik, return shipping prepaid, along with the bill of sale or other dated proof of purchase and the consumer's contact information.

This warranty is void if the product has been damaged by accident or unreasonable use, neglect, improper service or other causes not arising out of defects in materials or construction. This warranty does not cover the elimination of externally generated static or noise, or the correction of antenna problems or weak reception, damage to speakers, accessories, electrical systems, cosmetic damage or damage due to negligence, misuse, failure to follow operating instructions, accidental spills or customer applied cleaners, damage due to environmental causes such as floods, airborne fallout, chemicals, salt, hail, lightning or extreme temperatures, damage due to accidents, road hazards, fire, theft, loss or vandalism, damage due to improper connection to equipment of another manufacturer, modification of existing equipment, or Product which has been opened or tampered for any reason. Units which are found to be damaged by abuse resulting in thermally damaged voice coils are not covered by this warranty but may be replaced at the absolute and sole discretion of Power Acoustik. Unit must be returned to Power Acoustik, postage pre-paid, with bill of sale or other dated proof of purchase bearing the following information: consumer's name, telephone number, and address, authorized retailer's name and address, and product description. Please contact Power Acoustik warranty office at 800-724-1377, email to repairs@poweracoustik.com, or visit poweracoustik.com/warranty to obtain a Return Authorization Number prior to shipping the product.

Note: This warranty does not cover labor costs for the removal and reinstallation of the unit. IN ORDER FOR THE ONE-YEAR WARRANTY TO BE VALID, YOUR UNIT MUST BE SHIPPED WITH PROOF OF PURCHASE & INSTALLATION BY A POWER ACOUSTIK AUTHORIZED RETAILER. ALL UNITS RECEIVED BY POWER ACOUSTIK FOR WARRANTY REPAIR WITHOUT PROOF OF POWER ACOUSTIK AUTHORIZED DEALER INSTALLATION AND PURCHASE WILL BE COVERED BY THE LIMITED 90-DAY WARRANTY.

BY PURCHASING THIS PRODUCT, ALL WARRANTIES INCLUDING BUT NOT LIMITED TO EXPRESS WARRANTY, IMPLIED WARRANTY, WARRANTY OF MERCHANTABILITY, FITNESS FOR PARTICULAR PURPOSE, AND WARRANTY OF NON-INFRINGEMENT OF INTELLECTUAL PROPERTY ARE EXPRESSLY EXCLUDED TO THE MAXIMUM EXTENT ALLOWED BY LAW, AND POWER ACOUSTIK NEITHER ASSUMES NOR AUTHORIZES ANY PERSON TO ASSUME FOR IT ANY LIABILITY IN CONNECTION WITH THE SALE OF THE PRODUCT. POWER ACOUSTIK HAS ABSOLUTELY NO LIABILITY FOR ANY AND ALL ACTS OF THIRD PARTIES INCLUDING ITS AUTHORIZED DEALERS OR INSTALLERS. BY PURCHASING THIS PRODUCT, THE CONSUMER AGREES AND CONSENTS THAT ALL DISPUTES BETWEEN THE CONSUMER AND POWER ACOUSTIK SHALL BE RESOLVED IN ACCORDANCE WITH CALIFORNIA LAWS IN LOS ANGELES COUNTY, CALIFORNIA. Some states do not allow limitation on how long an implied warranty lasts. In such states, the limitation or exclusions of this Limited Warranty may not apply. Some states do not allow the exclusion or limitation of incidental or consequential damages. In such states, the exclusion or limitation of this Limited Warranty may not apply to you. This Limited Warranty gives you specific legal rights, and you may have other rights which vary from state to state.



POWER ACOUSTIK®

Please Keep This Information For Your Records

Product Model: _____

Serial Number: _____

Date Purchased: _____

Name of Dealer: _____

Dealer Address: _____

City: _____ State: _____ Zip: _____

Owners Registration Card.

Please complete and return immediately to the address on the reverse side

Name: _____

Address: _____

City: _____ State: _____ Zip: _____

Phone: _____ E-mail: _____

Vehicle Make/Model: _____

Product Model: _____

Serial Number: _____

Date Purchased: _____

Name of Dealer: _____

Dealer Address: _____

City: _____ State: _____ Zip: _____



STAMP

POWER ACOUSTIK®

1550 S. Maple Ave.
Montebello, CA 90640
Attn. Customer Service