



## HOW TO USE THIS INSTALL GUIDE

- 1** Open the Bookmarks menu and find your vehicle OR scroll down until you find the install guide for your vehicle.
- 2** Print only the pages for your vehicle using the advanced options in the Print menu.
- 3** Install your Maestro RR according to the guide for your vehicle.

## WARNING

Pressing the printer icon or “quick printing” this document will print all of the guides in this compilation.



# INSTALL GUIDE ACURA CSX WITH AMP WITHOUT NAV 2006-2011

RETAIN STEERING WHEEL CONTROLS, FACTORY AMPLIFIER AND MORE!



#### PRODUCTS REQUIRED

iDatalink Maestro RR Radio Replacement Interface  
iDatalink Maestro HO1 Installation Harness

#### OPTIONAL ACCESSORIES

None

#### PROGRAMMED FIRMWARE

ADS-RR(SR)-HON01-AS

NOTICE: Automotive Data Solutions Inc. (ADS) recommends having this installation performed by a certified technician. Logos and trademarks used here in are the properties of their respective owners.

# WELCOME

Congratulations on the purchase of your iDatalink Maestro RR Radio replacement solution. You are now a few simple steps away from enjoying your new car radio with enhanced features.

Before starting your installation, please ensure that your iDatalink Maestro module is programmed with the correct firmware and that you carefully review the Installation Diagram and Vehicle Wire Reference Chart.

**Please note that Maestro RR will only retain functionalities that were originally available in the vehicle.**

# NEED HELP?

 **1 866 427-2999**

 [support@idatalink.com](mailto:support@idatalink.com)

 [maestro.idatalink.com/support](http://maestro.idatalink.com/support)  
[www.12voltdata.com/forum](http://www.12voltdata.com/forum)

## DURING INSTALLATION

Installation Instructions	<b>3</b>
Wiring Diagram	<b>4</b>
Radio Wire Reference Chart	<b>5</b>

# INSTALLATION INSTRUCTIONS

## BEFORE INSTALLING

- To determine if the vehicle is equipped with a factory amplifier, look at the rear deck. If there is a subwoofer present in the rear deck, the vehicle has an amplifier. If there are only two speakers in the rear deck, it is NOT amplified.
- Remove the factory radio.

### STEP 1

- Unbox the aftermarket radio and locate its main harness.
- Make the connections shown on the wiring diagram from the aftermarket radio main harness to the H01 T-harness and match the wire functions.

### STEP 2

- Connect the white junction plug of the H01 T-harness to the 20 pin auxiliary harness. Connect the factory harness to the H01 T-harness.

### STEP 3

- Plug the OBDII connector into the OBDII of the vehicle, under driver dash.

### STEP 4

- Plug the aftermarket radio harnesses into the aftermarket radio.
- Plug the steering wheel control cable into the aftermarket radio.
- Insert the RCA connectors (AUX IN) into the aftermarket radio (if equipped).

### STEP 6

- Connect all the harnesses to the Maestro RR module then test your installation.

## TROUBLESHOOTING TIPS:

- To reset the module back its factory settings, turn the key to the OFF position then disconnect all connectors from the module. Press and hold the module's programming button and connect all the connectors back to the module. Wait, the module's LED will flash RED rapidly (this may take up to 10 seconds). Release the programming button. Wait, the LED will turn solid GREEN for 2 seconds.
- For technical assistance call 1-866-427-2999 or e-mail "support@idatalink.com". Visit us at "maestro.idatalink.com/support" and "www.12voltdata.com/forum/"

# WIRING DIAGRAM *with an Amplifier*

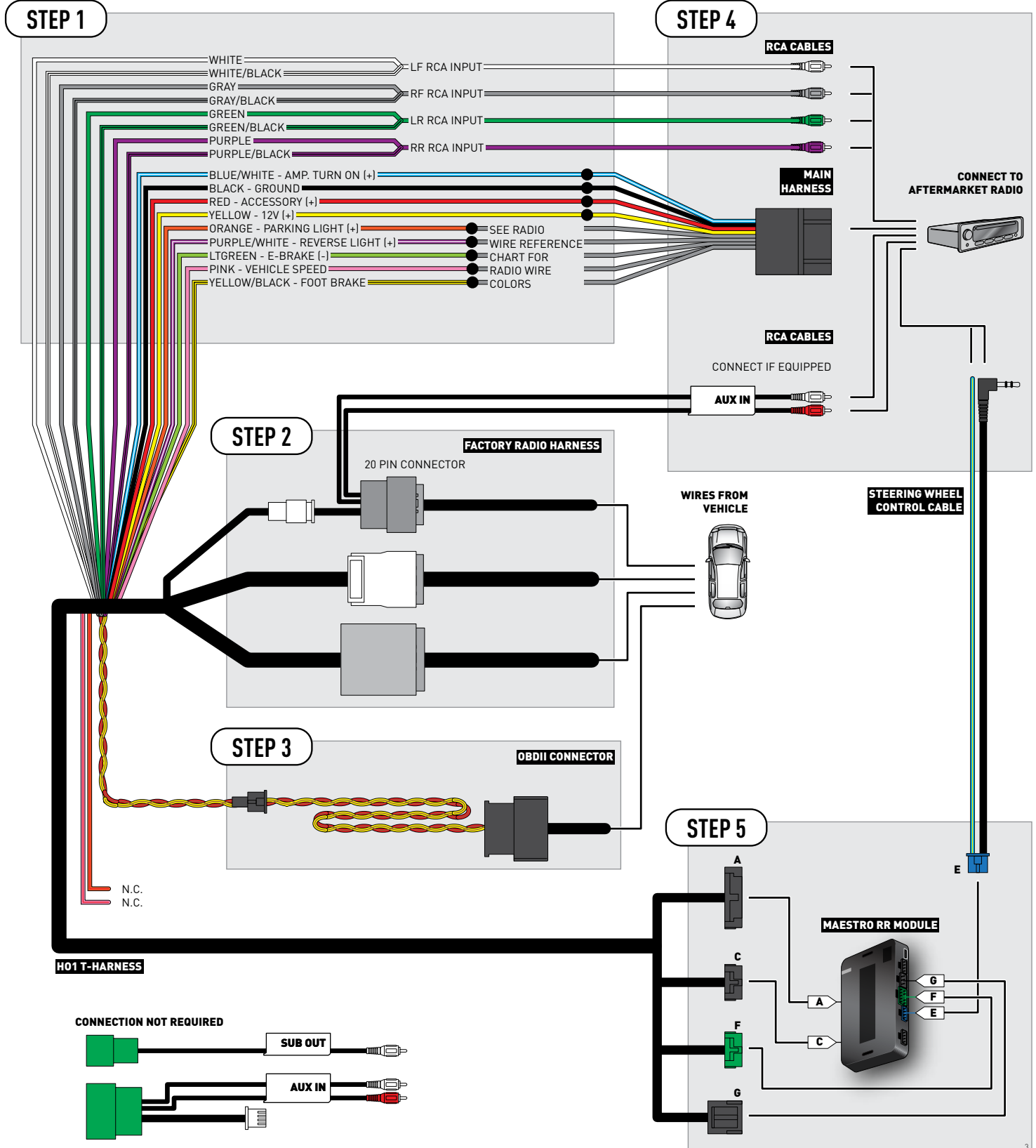

# RADIO WIRE REFERENCE CHART

Wire Description	Polarity	Wire Color on Maestro T-Harness	Wire Color on Alpine cable	Wire Color on Kenwood cable	Wire Color on Pioneer cable
Illumination	(+)	Orange	N/A	Orange/White	Orange/White
Reverse Light	(+)	Purple/White	Orange/White	Purple/White	Purple/White
E-Brake	(-)	Lt Green	Yellow/Blue	Lt Green	Lt Green
Foot Brake	(+)	Yellow/Black	Yellow/Black	N/A	N/A
VSS (vehicle speed sensor)	(DATA)	Pink	Green/White	N/A	Pink



# INSTALL GUIDE ACURA CSX WITH NAV 2006-2008

RETAIN STEERING WHEEL CONTROLS, FACTORY AMPLIFIER AND MORE!



#### PRODUCTS REQUIRED

iDatalink Maestro RR Radio Replacement Interface  
iDatalink Maestro HO1 Installation Harness

#### OPTIONAL ACCESSORIES

None

#### PROGRAMMED FIRMWARE

ADS-RR(SR)-HON01-AS

NOTICE: Automotive Data Solutions Inc. (ADS) recommends having this installation performed by a certified technician. Logos and trademarks used here in are the properties of their respective owners.

# WELCOME

Congratulations on the purchase of your iDatalink Maestro RR Radio replacement solution. You are now a few simple steps away from enjoying your new car radio with enhanced features.

Before starting your installation, please ensure that your iDatalink Maestro module is programmed with the correct firmware and that you carefully review the Installation Diagram and Vehicle Wire Reference Chart.

**Please note that Maestro RR will only retain functionalities that were originally available in the vehicle.**

# NEED HELP?

 **1 866 427-2999**

 **[support@idatalink.com](mailto:support@idatalink.com)**

 **[maestro.idatalink.com/support](http://maestro.idatalink.com/support)  
[www.12voltdata.com/forum](http://www.12voltdata.com/forum)**

## DURING INSTALLATION

Installation Instructions	<b>3</b>
Wiring Diagram	<b>4</b>
Radio Wire Reference Chart	<b>5</b>



# INSTALLATION INSTRUCTIONS

## STEP 1

- Unbox the aftermarket radio and locate its main harness.
- Remove the factory radio.
- Make the connections shown on the wiring diagram from the aftermarket radio main harness to the H01 T-harness and match the wire functions.

## STEP 2

- Connect the white junction plug of the H01 T-harness to the 22 pin auxiliary harness. Connect the factory harness to the H01 T-harness.
- Connect the ORANGE/RED wire from the H01 T-harness to the GREEN wire in pin 4 of the factory harness.

## STEP 3

- Plug the OBDII connector into the OBDII of the vehicle, under driver dash.

## STEP 4

- Plug the aftermarket radio harnesses into the aftermarket radio.
- Plug the steering wheel control cable into the aftermarket radio.
- Insert the RCA connectors into the aftermarket radio.

## STEP 5

- Connect all the harnesses to the Maestro RR module then test your installation.

## TROUBLESHOOTING TIPS:

- To reset the module back its factory settings, turn the key to the OFF position then disconnect all connectors from the module. Press and hold the module's programming button and connect all the connectors back to the module. Wait, the module's LED will flash RED rapidly (this may take up to 10 seconds). Release the programming button. Wait, the LED will turn solid GREEN for 2 seconds.
- For technical assistance call 1-866-427-2999 or e-mail "support@idatalink.com". Visit us at "maestro.idatalink.com/support" and "www.12voltdata.com/forum/"

# WIRING DIAGRAM *with Navigation*

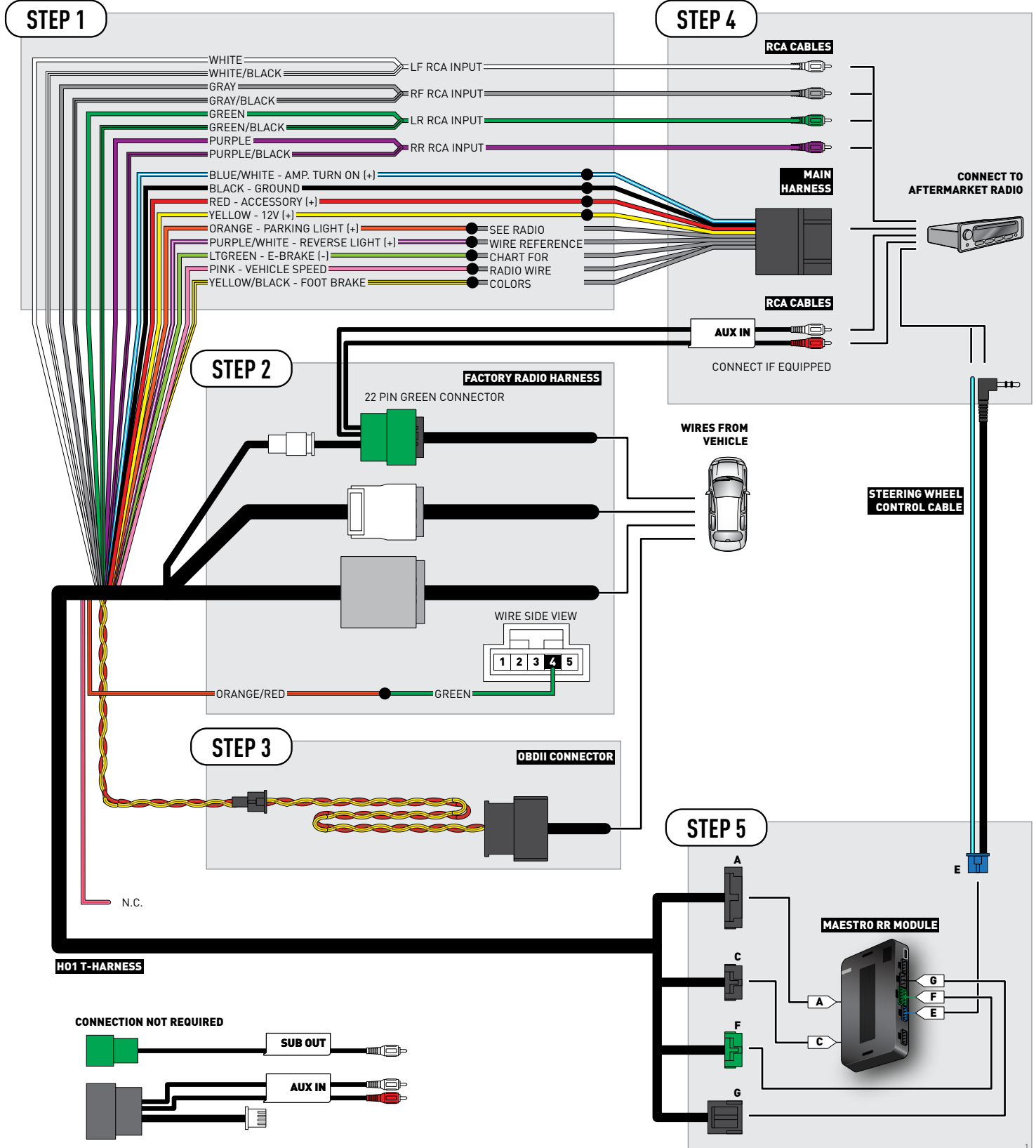

# RADIO WIRE REFERENCE CHART

Wire Description	Polarity	Wire Color on Maestro T-Harness	Wire Color on Alpine cable	Wire Color on Kenwood cable	Wire Color on Pioneer cable
Illumination	(+)	Orange	N/A	Orange/White	Orange/White
Reverse Light	(+)	Purple/White	Orange/White	Purple/White	Purple/White
E-Brake	(-)	Lt Green	Yellow/Blue	Lt Green	Lt Green
Foot Brake	(+)	Yellow/Black	Yellow/Black	N/A	N/A
VSS (vehicle speed sensor)	(DATA)	Pink	Green/White	N/A	Pink



# INSTALL GUIDE ACURA CSX WITHOUT AMP WITHOUT NAV 2006-2011

RETAIN STEERING WHEEL CONTROLS, FACTORY AMPLIFIER AND MORE!



#### PRODUCTS REQUIRED

iDatalink Maestro RR Radio Replacement Interface  
iDatalink Maestro HO1 Installation Harness

#### OPTIONAL ACCESSORIES

None

#### PROGRAMMED FIRMWARE

ADS-RR(SR)-HON01-AS

NOTICE: Automotive Data Solutions Inc. (ADS) recommends having this installation performed by a certified technician. Logos and trademarks used here in are the properties of their respective owners.

# WELCOME

Congratulations on the purchase of your iDatalink Maestro RR Radio replacement solution. You are now a few simple steps away from enjoying your new car radio with enhanced features.

Before starting your installation, please ensure that your iDatalink Maestro module is programmed with the correct firmware and that you carefully review the Installation Diagram and Vehicle Wire Reference Chart.

**Please note that Maestro RR will only retain functionalities that were originally available in the vehicle.**

# NEED HELP?

 **1 866 427-2999**

 **[support@idatalink.com](mailto:support@idatalink.com)**

 **[maestro.idatalink.com/support](http://maestro.idatalink.com/support)  
[www.12voltdata.com/forum](http://www.12voltdata.com/forum)**

## DURING INSTALLATION

Installation Instructions	<b>3</b>
Wiring Diagram	<b>4</b>
Radio Wire Reference Chart	<b>5</b>

# INSTALLATION INSTRUCTIONS

## BEFORE INSTALLING

- To determine if the vehicle is equipped with a factory amplifier, look at the rear deck. If there is a subwoofer present in the rear deck, the vehicle has an amplifier. If there are only two speakers in the rear deck, it is NOT amplified.
- Remove the factory radio.

### STEP 1

- Unbox the aftermarket radio and locate its main harness.
- Make the connections shown on the wiring diagram from the aftermarket radio main harness to the H01 T-harness and match the wire functions.

### STEP 2

- Connect the white junction plug of the H01 T-harness to the 20 pin auxiliary harness. Connect the factory harness to the H01 T-harness.

### STEP 3

- Plug the OBDII connector into the OBDII of the vehicle, under driver dash.

### STEP 4

- Plug the aftermarket radio harnesses into the aftermarket radio.
- Plug the steering wheel control cable into the aftermarket radio.
- Insert the RCA connectors (AUX IN) into the aftermarket radio (if equipped).

### STEP 6

- Connect all the harnesses to the Maestro RR module then test your installation.

## TROUBLESHOOTING TIPS:

- To reset the module back its factory settings, turn the key to the OFF position then disconnect all connectors from the module. Press and hold the module's programming button and connect all the connectors back to the module. Wait, the module's LED will flash RED rapidly (this may take up to 10 seconds). Release the programming button. Wait, the LED will turn solid GREEN for 2 seconds.
- For technical assistance call 1-866-427-2999 or e-mail "support@idatalink.com". Visit us at "maestro.idatalink.com/support" and "www.12voltdata.com/forum/"

# WIRING DIAGRAM *without an Amplifier*

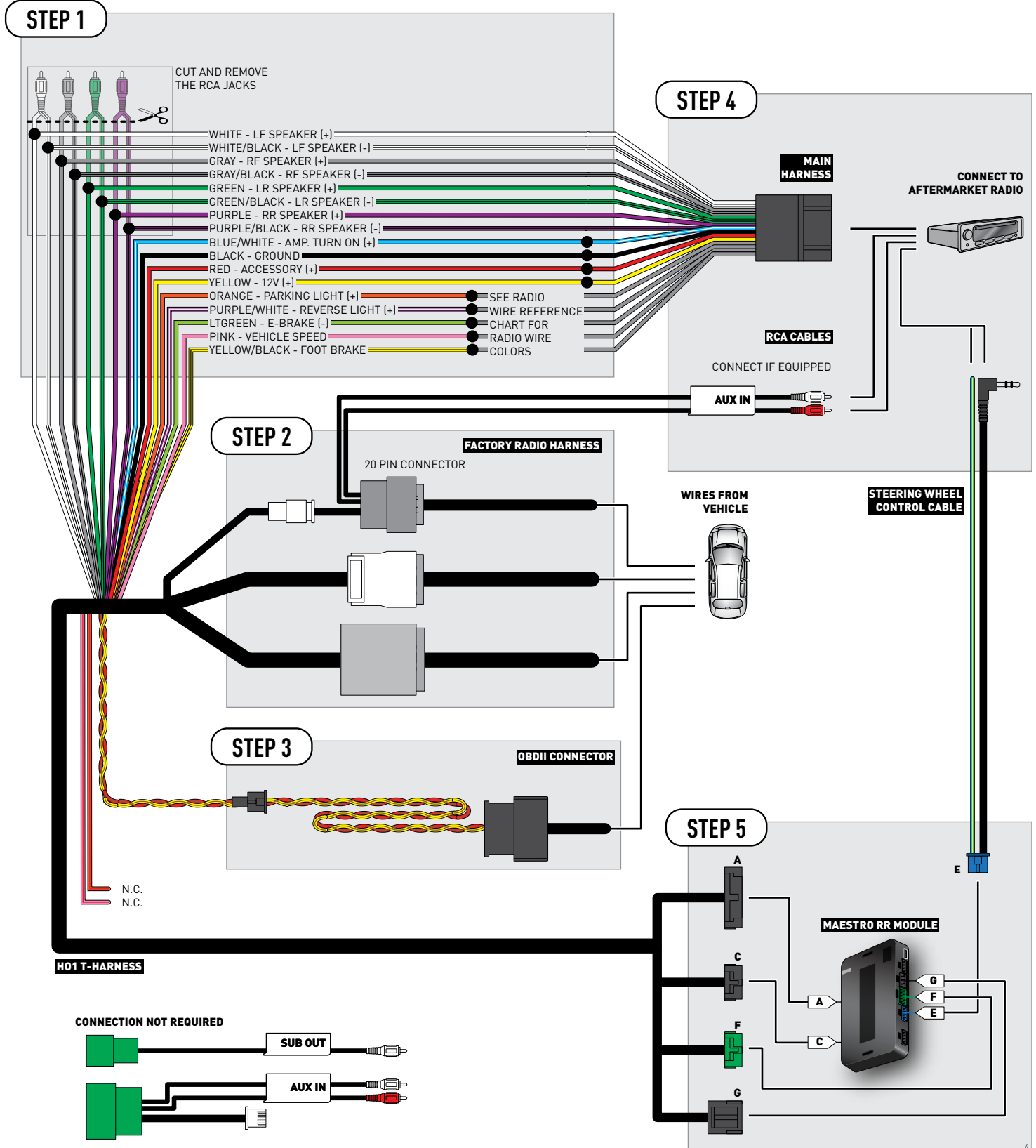

# RADIO WIRE REFERENCE CHART

Wire Description	Polarity	Wire Color on Maestro T-Harness	Wire Color on Alpine cable	Wire Color on Kenwood cable	Wire Color on Pioneer cable
Illumination	(+)	Orange	N/A	Orange/White	Orange/White
Reverse Light	(+)	Purple/White	Orange/White	Purple/White	Purple/White
E-Brake	(-)	Lt Green	Yellow/Blue	Lt Green	Lt Green
Foot Brake	(+)	Yellow/Black	Yellow/Black	N/A	N/A
VSS (vehicle speed sensor)	(DATA)	Pink	Green/White	N/A	Pink





# INSTALL GUIDE HONDA CIVIC WITH AMP WITHOUT NAV 2006-2011

RETAIN STEERING WHEEL CONTROLS, FACTORY AMPLIFIER AND MORE!



#### PRODUCTS REQUIRED

iDatalink Maestro RR Radio Replacement Interface  
iDatalink Maestro HO1 Installation Harness

#### OPTIONAL ACCESSORIES

None

#### PROGRAMMED FIRMWARE

ADS-RR(SR)-HON01-AS

NOTICE: Automotive Data Solutions Inc. (ADS) recommends having this installation performed by a certified technician. Logos and trademarks used here in are the properties of their respective owners.

# WELCOME

Congratulations on the purchase of your iDatalink Maestro RR Radio replacement solution. You are now a few simple steps away from enjoying your new car radio with enhanced features.

Before starting your installation, please ensure that your iDatalink Maestro module is programmed with the correct firmware and that you carefully review the Installation Diagram and Vehicle Wire Reference Chart.

**Please note that Maestro RR will only retain functionalities that were originally available in the vehicle.**

# NEED HELP?

 **1 866 427-2999**

 **[support@idatalink.com](mailto:support@idatalink.com)**

 **[maestro.idatalink.com/support](http://maestro.idatalink.com/support)  
[www.12voltdata.com/forum](http://www.12voltdata.com/forum)**

## DURING INSTALLATION

Installation Instructions	<b>3</b>
Wiring Diagram	<b>4</b>
Radio Wire Reference Chart	<b>5</b>

# INSTALLATION INSTRUCTIONS

## BEFORE INSTALLING

- To determine if the vehicle is equipped with a factory amplifier, look at the rear deck. If there is a subwoofer present in the rear deck, the vehicle has an amplifier. If there are only two speakers in the rear deck, it is NOT amplified.
- Remove the factory radio.

### STEP 1

- Unbox the aftermarket radio and locate its main harness.
- Make the connections shown on the wiring diagram from the aftermarket radio main harness to the H01 T-harness and match the wire functions.

### STEP 2

- Connect the white junction plug of the H01 T-harness to the 20 pin auxiliary harness. Connect the factory harness to the H01 T-harness.

### STEP 3

- Plug the OBDII connector into the OBDII of the vehicle, under driver dash.

### STEP 4

- Plug the aftermarket radio harnesses into the aftermarket radio.
- Plug the steering wheel control cable into the aftermarket radio.
- Insert the RCA connectors (AUX IN) into the aftermarket radio (if equipped).

### STEP 6

- Connect all the harnesses to the Maestro RR module then test your installation.

## TROUBLESHOOTING TIPS:

- To reset the module back its factory settings, turn the key to the OFF position then disconnect all connectors from the module. Press and hold the module's programming button and connect all the connectors back to the module. Wait, the module's LED will flash RED rapidly (this may take up to 10 seconds). Release the programming button. Wait, the LED will turn solid GREEN for 2 seconds.
- For technical assistance call 1-866-427-2999 or e-mail "support@idatalink.com". Visit us at "maestro.idatalink.com/support" and "www.12voltdata.com/forum/"

# WIRING DIAGRAM *with an Amplifier*

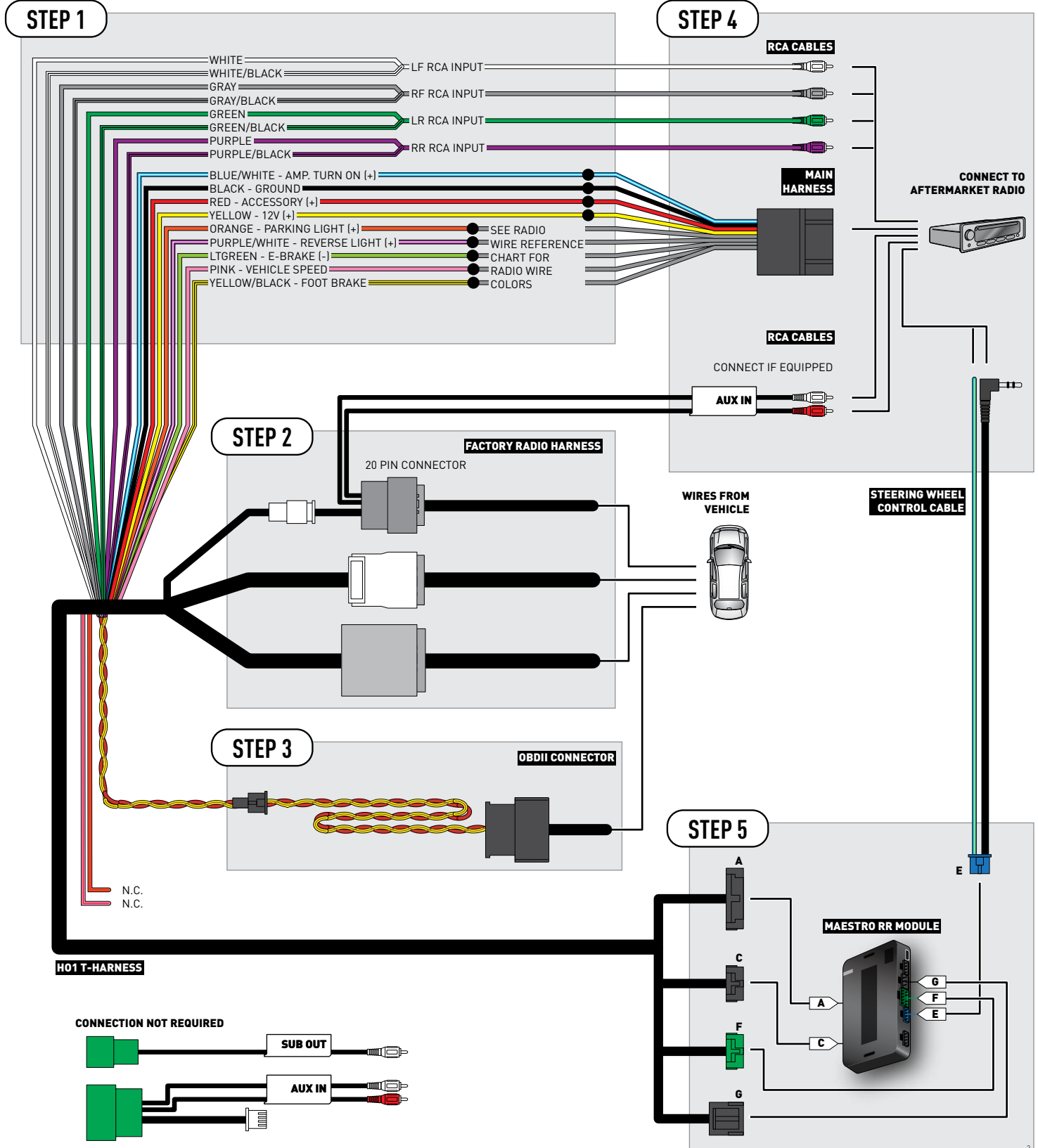

# RADIO WIRE REFERENCE CHART

Wire Description	Polarity	Wire Color on Maestro T-Harness	Wire Color on Alpine cable	Wire Color on Kenwood cable	Wire Color on Pioneer cable
Illumination	(+)	Orange	N/A	Orange/White	Orange/White
Reverse Light	(+)	Purple/White	Orange/White	Purple/White	Purple/White
E-Brake	(-)	Lt Green	Yellow/Blue	Lt Green	Lt Green
Foot Brake	(+)	Yellow/Black	Yellow/Black	N/A	N/A
VSS (vehicle speed sensor)	(DATA)	Pink	Green/White	N/A	Pink



# INSTALL GUIDE HONDA CIVIC WITH NAV 2006-2008

RETAIN STEERING WHEEL CONTROLS, FACTORY AMPLIFIER AND MORE!



#### PRODUCTS REQUIRED

iDatalink Maestro RR Radio Replacement Interface  
iDatalink Maestro HO1 Installation Harness

#### OPTIONAL ACCESSORIES

None

#### PROGRAMMED FIRMWARE

ADS-RR(SR)-HON01-AS

NOTICE: Automotive Data Solutions Inc. (ADS) recommends having this installation performed by a certified technician. Logos and trademarks used here in are the properties of their respective owners.

# WELCOME

Congratulations on the purchase of your iDatalink Maestro RR Radio replacement solution. You are now a few simple steps away from enjoying your new car radio with enhanced features.

Before starting your installation, please ensure that your iDatalink Maestro module is programmed with the correct firmware and that you carefully review the Installation Diagram and Vehicle Wire Reference Chart.

**Please note that Maestro RR will only retain functionalities that were originally available in the vehicle.**

# NEED HELP?

 **1 866 427-2999**

 [support@idatalink.com](mailto:support@idatalink.com)

 [maestro.idatalink.com/support](http://maestro.idatalink.com/support)  
[www.12voltdata.com/forum](http://www.12voltdata.com/forum)

## DURING INSTALLATION

Installation Instructions	3
Wiring Diagram	4
Radio Wire Reference Chart	5

# INSTALLATION INSTRUCTIONS

## STEP 1

- Unbox the aftermarket radio and locate its main harness.
- Remove the factory radio.
- Make the connections shown on the wiring diagram from the aftermarket radio main harness to the H01 T-harness and match the wire functions.

## STEP 2

- Connect the white junction plug of the H01 T-harness to the 22 pin auxiliary harness. Connect the factory harness to the H01 T-harness.
- Connect the ORANGE/RED wire from the H01 T-harness to the GREEN wire in pin 4 of the factory harness.

## STEP 3

- Plug the OBDII connector into the OBDII of the vehicle, under driver dash.

## STEP 4

- Plug the aftermarket radio harnesses into the aftermarket radio.
- Plug the steering wheel control cable into the aftermarket radio.
- Insert the RCA connectors into the aftermarket radio.

## STEP 5

- Connect all the harnesses to the Maestro RR module then test your installation.

### TROUBLESHOOTING TIPS:

- To reset the module back its factory settings, turn the key to the OFF position then disconnect all connectors from the module. Press and hold the module's programming button and connect all the connectors back to the module. Wait, the module's LED will flash RED rapidly (this may take up to 10 seconds). Release the programming button. Wait, the LED will turn solid GREEN for 2 seconds.
- For technical assistance call 1-866-427-2999 or e-mail "support@idatalink.com". Visit us at "maestro.idatalink.com/support" and "www.12voltdata.com/forum/"



# WIRING DIAGRAM *with Navigation*

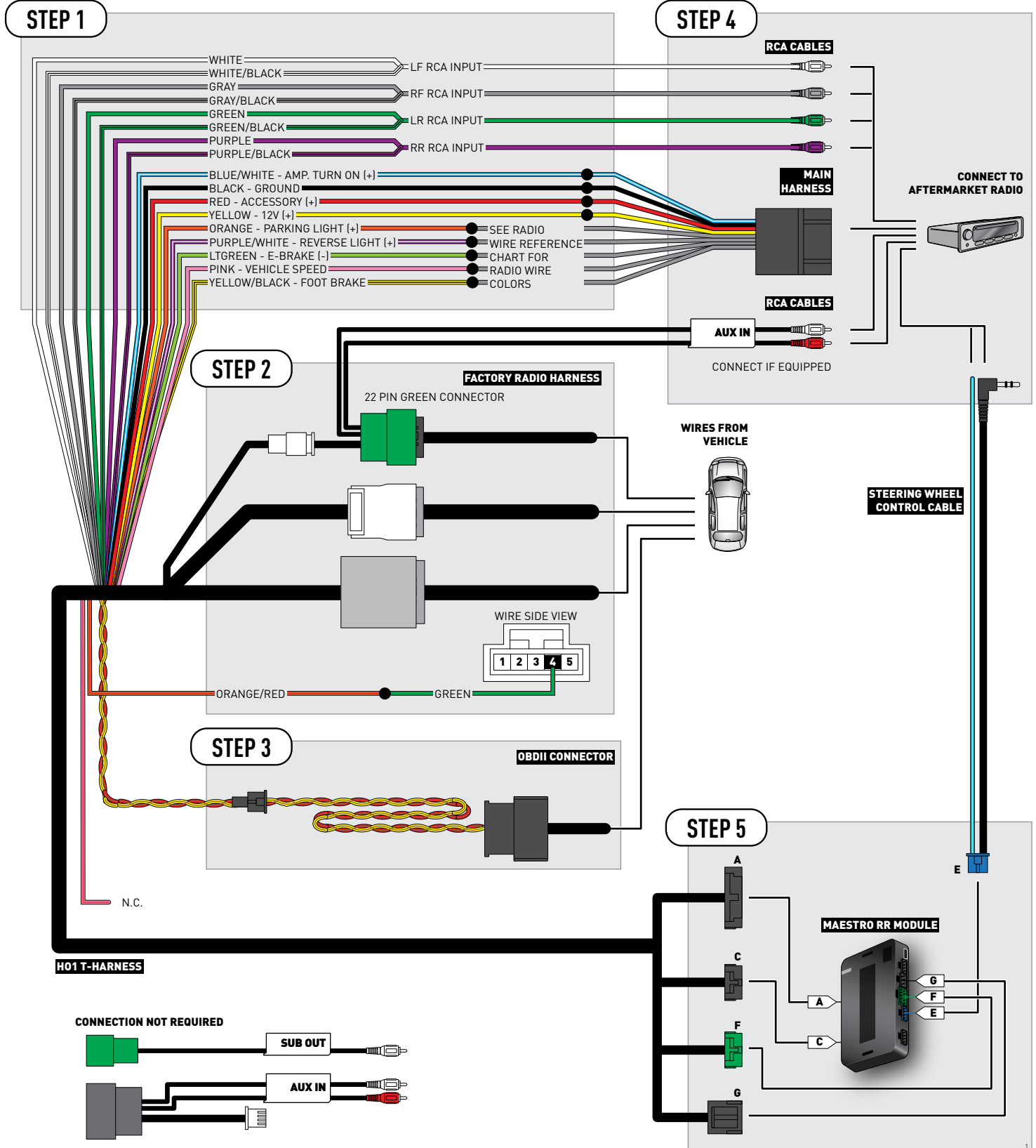

# RADIO WIRE REFERENCE CHART

Wire Description	Polarity	Wire Color on Maestro T-Harness	Wire Color on Alpine cable	Wire Color on Kenwood cable	Wire Color on Pioneer cable
Illumination	(+)	Orange	N/A	Orange/White	Orange/White
Reverse Light	(+)	Purple/White	Orange/White	Purple/White	Purple/White
E-Brake	(-)	Lt Green	Yellow/Blue	Lt Green	Lt Green
Foot Brake	(+)	Yellow/Black	Yellow/Black	N/A	N/A
VSS (vehicle speed sensor)	(DATA)	Pink	Green/White	N/A	Pink



# INSTALL GUIDE HONDA CIVIC WITHOUT AMP WITHOUT NAV 2006-2011

RETAIN STEERING WHEEL CONTROLS, FACTORY AMPLIFIER AND MORE!



#### PRODUCTS REQUIRED

iDatalink Maestro RR Radio Replacement Interface  
iDatalink Maestro HO1 Installation Harness

#### OPTIONAL ACCESSORIES

None

#### PROGRAMMED FIRMWARE

ADS-RR(SR)-HON01-AS

NOTICE: Automotive Data Solutions Inc. (ADS) recommends having this installation performed by a certified technician. Logos and trademarks used here in are the properties of their respective owners.

# WELCOME

Congratulations on the purchase of your iDatalink Maestro RR Radio replacement solution. You are now a few simple steps away from enjoying your new car radio with enhanced features.

Before starting your installation, please ensure that your iDatalink Maestro module is programmed with the correct firmware and that you carefully review the Installation Diagram and Vehicle Wire Reference Chart.

**Please note that Maestro RR will only retain functionalities that were originally available in the vehicle.**

# NEED HELP?

 **1 866 427-2999**

 [support@idatalink.com](mailto:support@idatalink.com)

 [maestro.idatalink.com/support](http://maestro.idatalink.com/support)  
[www.12voltdata.com/forum](http://www.12voltdata.com/forum)

## DURING INSTALLATION

Installation Instructions	<b>3</b>
Wiring Diagram	<b>4</b>
Radio Wire Reference Chart	<b>5</b>

# INSTALLATION INSTRUCTIONS

## BEFORE INSTALLING

- To determine if the vehicle is equipped with a factory amplifier, look at the rear deck. If there is a subwoofer present in the rear deck, the vehicle has an amplifier. If there are only two speakers in the rear deck, it is NOT amplified.
- Remove the factory radio.

### STEP 1

- Unbox the aftermarket radio and locate its main harness.
- Make the connections shown on the wiring diagram from the aftermarket radio main harness to the H01 T-harness and match the wire functions.

### STEP 2

- Connect the white junction plug of the H01 T-harness to the 20 pin auxiliary harness. Connect the factory harness to the H01 T-harness.

### STEP 3

- Plug the OBDII connector into the OBDII of the vehicle, under driver dash.

### STEP 4

- Plug the aftermarket radio harnesses into the aftermarket radio.
- Plug the steering wheel control cable into the aftermarket radio.
- Insert the RCA connectors (AUX IN) into the aftermarket radio (if equipped).

### STEP 6

- Connect all the harnesses to the Maestro RR module then test your installation.

## TROUBLESHOOTING TIPS:

- To reset the module back its factory settings, turn the key to the OFF position then disconnect all connectors from the module. Press and hold the module's programming button and connect all the connectors back to the module. Wait, the module's LED will flash RED rapidly (this may take up to 10 seconds). Release the programming button. Wait, the LED will turn solid GREEN for 2 seconds.
- For technical assistance call 1-866-427-2999 or e-mail "support@idatalink.com". Visit us at "maestro.idatalink.com/support" and "www.12voltdata.com/forum/"

# WIRING DIAGRAM *without an Amplifier*

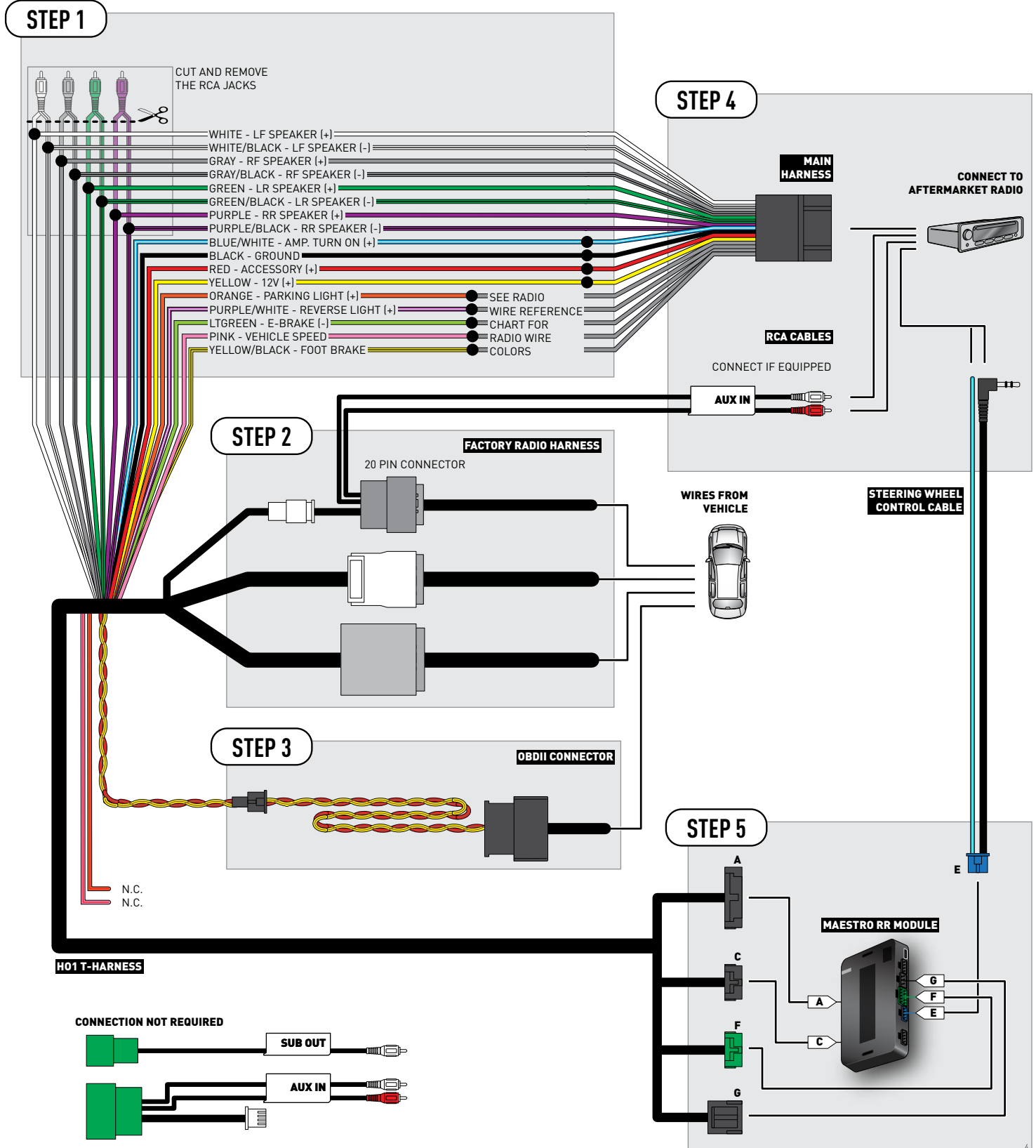

# RADIO WIRE REFERENCE CHART

Wire Description	Polarity	Wire Color on Maestro T-Harness	Wire Color on Alpine cable	Wire Color on Kenwood cable	Wire Color on Pioneer cable
Illumination	(+)	Orange	N/A	Orange/White	Orange/White
Reverse Light	(+)	Purple/White	Orange/White	Purple/White	Purple/White
E-Brake	(-)	Lt Green	Yellow/Blue	Lt Green	Lt Green
Foot Brake	(+)	Yellow/Black	Yellow/Black	N/A	N/A
VSS (vehicle speed sensor)	(DATA)	Pink	Green/White	N/A	Pink



# INSTALL GUIDE HONDA CRV WITH NAV 2007-2009

RETAIN STEERING WHEEL CONTROLS, FACTORY AMPLIFIER AND MORE!



#### PRODUCTS REQUIRED

iDatalink Maestro RR Radio Replacement Interface  
iDatalink Maestro HO1 Installation Harness

#### OPTIONAL ACCESSORIES

None

#### PROGRAMMED FIRMWARE

ADS-RR(SR)-HON01-AS

NOTICE: Automotive Data Solutions Inc. (ADS) recommends having this installation performed by a certified technician. Logos and trademarks used here in are the properties of their respective owners.



# WELCOME

Congratulations on the purchase of your iDatalink Maestro RR Radio replacement solution. You are now a few simple steps away from enjoying your new car radio with enhanced features.

Before starting your installation, please ensure that your iDatalink Maestro module is programmed with the correct firmware and that you carefully review the Installation Diagram and Vehicle Wire Reference Chart.

**Please note that Maestro RR will only retain functionalities that were originally available in the vehicle.**

# NEED HELP?

 **1 866 427-2999**

 **[support@idatalink.com](mailto:support@idatalink.com)**

 **[maestro.idatalink.com/support](http://maestro.idatalink.com/support)  
[www.12voltdata.com/forum](http://www.12voltdata.com/forum)**

## DURING INSTALLATION

Installation Instructions	<b>3</b>
Wiring Diagram	<b>4</b>
Radio Wire Reference Chart	<b>5</b>

# INSTALLATION INSTRUCTIONS

## STEP 1

- Unbox the aftermarket radio and locate its main harness.
- Remove the factory radio.
- Make the connections shown on the wiring diagram from the aftermarket radio main harness to the H01 T-harness and match the wire functions.

## STEP 2

- Connect the white junction plug of the H01 T-harness to the 22 pin auxiliary harness.
- Connect the factory harness to the H01 T-harness.
- Connect the subwoofer harness to the vehicle (if equipped).
- Connect the ORANGE/RED wire from the H01 T-harness to the GREEN wire in pin 4 of the factory harness.

## STEP 3

- Connect the PINK/RED wire from the H01 T-harness to the BLUE wire in pin 2 at the Bluetooth module, located below the radio, in the center of the dash.

## STEP 3

- Plug the OBDII connector into the OBDII of the vehicle, under driver dash.

## STEP 4

- Plug the aftermarket radio harnesses into the aftermarket radio.
- Plug the steering wheel control cable into the aftermarket radio.
- Insert the RCA connectors into the aftermarket radio.

## STEP 6

- Connect all the harnesses to the Maestro RR module then test your installation.

## TROUBLESHOOTING TIPS:

- To reset the module back its factory settings, turn the key to the OFF position then disconnect all connectors from the module. Press and hold the module's programming button and connect all the connectors back to the module. Wait, the module's LED will flash RED rapidly (this may take up to 10 seconds). Release the programming button. Wait, the LED will turn solid GREEN for 2 seconds.
- For technical assistance call 1-866-427-2999 or e-mail "support@idatalink.com". Visit us at "maestro.idatalink.com/support" and "www.12voltdata.com/forum/"

# WIRING DIAGRAM *with Navigation*

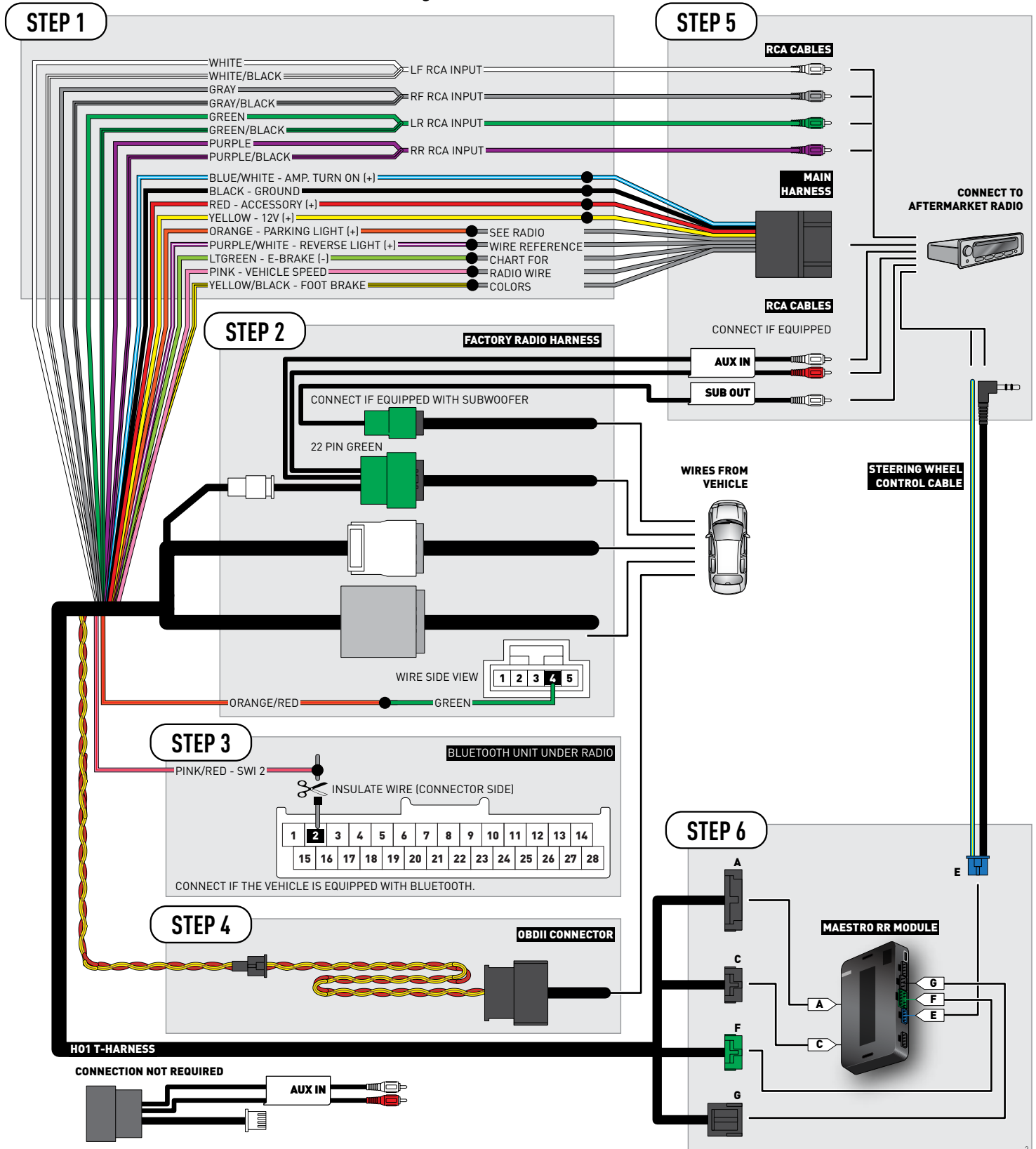

# RADIO WIRE REFERENCE CHART

Wire Description	Polarity	Wire Color on Maestro T-Harness	Wire Color on Alpine cable	Wire Color on Kenwood cable	Wire Color on Pioneer cable
Illumination	(+)	Orange	N/A	Orange/White	Orange/White
Reverse Light	(+)	Purple/White	Orange/White	Purple/White	Purple/White
E-Brake	(-)	Lt Green	Yellow/Blue	Lt Green	Lt Green
Foot Brake	(+)	Yellow/Black	Yellow/Black	N/A	N/A
VSS (vehicle speed sensor)	(DATA)	Pink	Green/White	N/A	Pink



# INSTALL GUIDE HONDA CRV WITHOUT NAV 2007-2011

RETAIN STEERING WHEEL CONTROLS, FACTORY AMPLIFIER AND MORE!



#### PRODUCTS REQUIRED

iDatalink Maestro RR Radio Replacement Interface  
iDatalink Maestro HO1 Installation Harness

#### OPTIONAL ACCESSORIES

None

#### PROGRAMMED FIRMWARE

ADS-RR(SR)-HON01-AS

NOTICE: Automotive Data Solutions Inc. (ADS) recommends having this installation performed by a certified technician. Logos and trademarks used here in are the properties of their respective owners.

# WELCOME

Congratulations on the purchase of your iDatalink Maestro RR Radio replacement solution. You are now a few simple steps away from enjoying your new car radio with enhanced features.

Before starting your installation, please ensure that your iDatalink Maestro module is programmed with the correct firmware and that you carefully review the Installation Diagram and Vehicle Wire Reference Chart.

**Please note that Maestro RR will only retain functionalities that were originally available in the vehicle.**

# NEED HELP?

 **1 866 427-2999**

 [support@idatalink.com](mailto:support@idatalink.com)

 [maestro.idatalink.com/support](http://maestro.idatalink.com/support)  
[www.12voltdata.com/forum](http://www.12voltdata.com/forum)

## DURING INSTALLATION

Installation Instructions	<b>3</b>
Wiring Diagram	<b>4</b>
Radio Wire Reference Chart	<b>5</b>

# INSTALLATION INSTRUCTIONS

## STEP 1

- Unbox the aftermarket radio and locate its main harness.
- Remove the factory radio.
- Make the connections shown on the wiring diagram from the aftermarket radio main harness to the H01 T-harness and match the wire functions.

## STEP 2

- Connect the white junction plug of the H01 T-harness to the 20 pin auxiliary harness. Connect the factory harness to the H01 T-harness.

## STEP 3

- Plug the OBDII connector into the OBDII of the vehicle, under driver dash.

## STEP 4

- Plug the aftermarket radio harnesses into the aftermarket radio.
- Plug the steering wheel control cable into the aftermarket radio.
- Insert the RCA connectors (AUX IN) into the aftermarket radio (if equipped).

## STEP 6

- Connect all the harnesses to the Maestro RR module then test your installation.

## TROUBLESHOOTING TIPS:

- To reset the module back its factory settings, turn the key to the OFF position then disconnect all connectors from the module. Press and hold the module's programming button and connect all the connectors back to the module. Wait, the module's LED will flash RED rapidly (this may take up to 10 seconds). Release the programming button. Wait, the LED will turn solid GREEN for 2 seconds.
- For technical assistance call 1-866-427-2999 or e-mail "support@idatalink.com". Visit us at "maestro.idatalink.com/support" and "www.12voltdata.com/forum/"

# WIRING DIAGRAM *without an Amplifier*

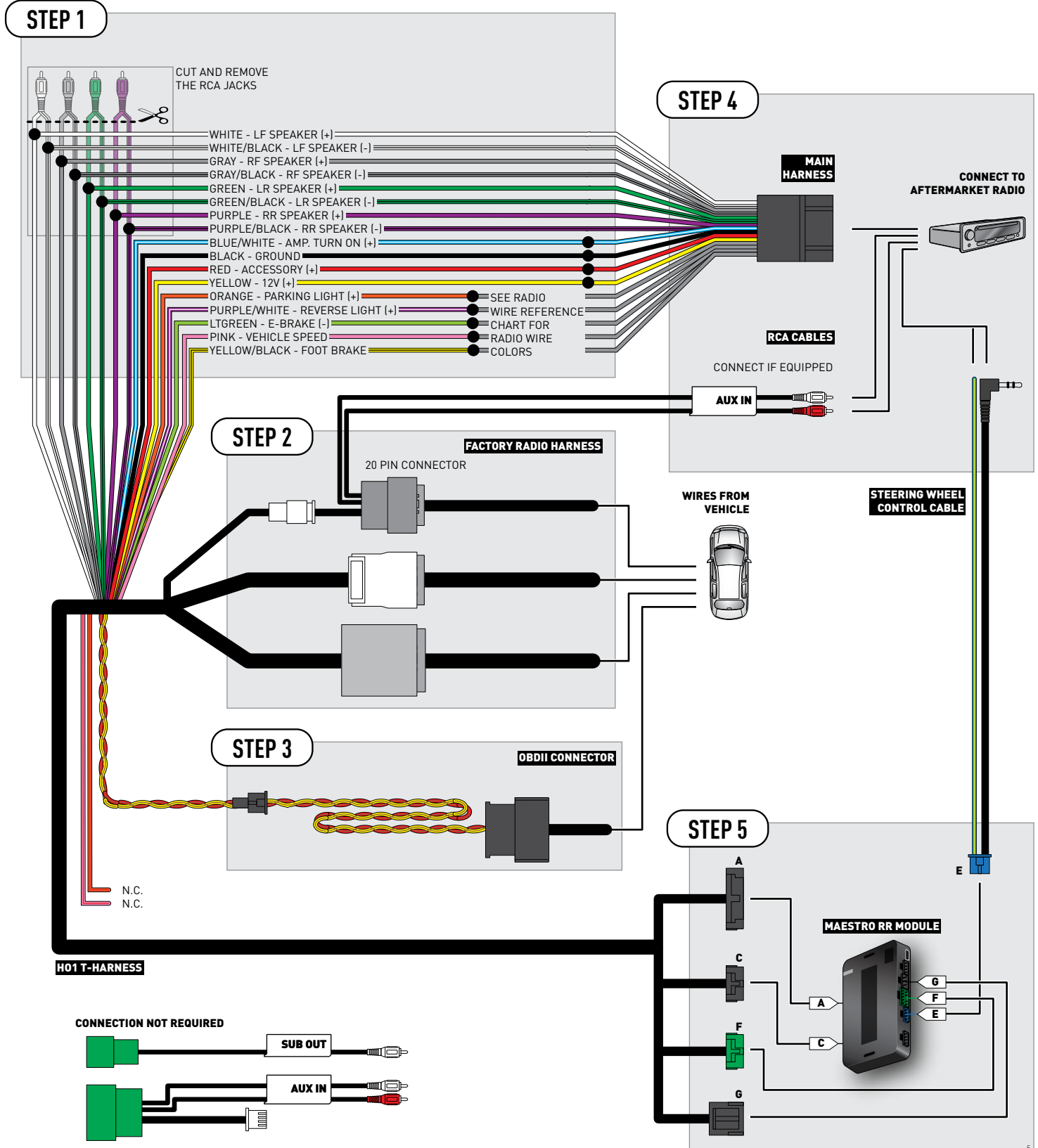



# RADIO WIRE REFERENCE CHART

Wire Description	Polarity	Wire Color on Maestro T-Harness	Wire Color on Alpine cable	Wire Color on Kenwood cable	Wire Color on Pioneer cable
Illumination	(+)	Orange	N/A	Orange/White	Orange/White
Reverse Light	(+)	Purple/White	Orange/White	Purple/White	Purple/White
E-Brake	(-)	Lt Green	Yellow/Blue	Lt Green	Lt Green
Foot Brake	(+)	Yellow/Black	Yellow/Black	N/A	N/A
VSS (vehicle speed sensor)	(DATA)	Pink	Green/White	N/A	Pink