

FOR VEHICLE USE ONLY/
POUR UNE UTILISATION À L'INTÉRIEUR D'UN VÉHICULE UNIQUEMENT/SÓLO PARA VEHÍCULOS

ALPINE®

KTA-200M

MONO POWER AMPLIFIER

- **OWNER'S MANUAL**
Please read this manual to maximize your enjoyment of the outstanding performance and feature capabilities of the equipment, then retain the manual for future reference.
- **MODE D'EMPLOI**
Veuillez lire ce mode d'emploi pour tirer pleinement profit des excellentes performances et fonctions de cet appareil, et conservez-le pour toute référence future.
- **MANUAL DE OPERACION**
Lea este manual, por favor, para disfrutar al máximo de las excepcionales prestaciones y posibilidades funcionales que ofrece el equipo, luego guarde el manual para usarlo como referencia en el futuro.

ALPINE ELECTRONICS, INC.
Tokyo office:
1-1-8 Nishi-Gotanda, Shinagawa-ku,
Tokyo 141-8501, Japan
Phone: 81(3) 3494-1101

**ALPINE ELECTRONICS
MARKETING, INC.**
1-7, Yukigaya-otsukamachi, Ota-ku,
Tokyo, 145-0067, Japan
Phone: 81(3)5499-8111

ALPINE ELECTRONICS GMBH
Ohmstrasse 4, D-85716
Unterschleissheim Germany
Phone: 49(0)89-324264-0

**ALPINE ELECTRONICS OF
AMERICA**
1500 Atlantic Blvd.
Auburn Hills, Michigan 48326 USA
Tel: 1-800-ALPINE-1 (1-800-257-4631)

**ALPINE ELECTRONICS
FRANCE S.A.R.L.**
184 allée des Erables
CS 52016 – Villepinte 95 945 Roissy
CDG cedex FRANCE
phone: +33 1 48 63 89 89

ALPINE ITALIA S.P.A.
Viale C. Colombo 8 20090 Trezzano
Sul Naviglio (MI), Italy
phone: 39(02)484781

**ALPINE ELECTRONICS OF
U.K., LTD**
Alpine House Earplace Business
Park Fletchamstead Highway
Coventry CV4, 9TW, U.K.
phone: 44-2476-719500

**ALPINE ELECTRONICS DE
ESPANA S.A.**
Portal de Gamarra 36 Pabellon 32,
01013 Vitoria (Alava)
APDO 133 SPAIN
phone: 34(945)283588

**ALPINE ELECTRONICS OF
AUSTRALIA PTY., LTD**
161-165 Princes Highway
Hallam Victoria 3803 AUSTRALIA
phone: 61(3)8787-1200

**ALPINE ELECTRONICS
(CHINA) CO., LTD**
East 28F, Hanwei Plaza No.7
Guanghua Street Chaoyang district,
Beijing (100004) PR CHINA
Phone: 86(10)6566-0308

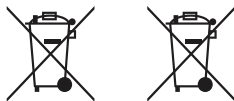

ENGLISH

Information on Disposal of Old Electrical and Electronic Equipment and Battery (applicable for countries that have adopted separate waste collection systems)

If you want to dispose this product, do not mix it with general household waste. There is a separate collection system for used electronic products in accordance with legislation that requires proper treatment, recovery and recycling. Contact your local authority for details in locating a recycle facility nearest to you. Proper recycling and waste disposal will help conserve resources whilst preventing detrimental effects on our health and the environment.

ESPAÑOL

Información sobre la eliminación de Viejos Equipos Eléctricos y Electrónicos, así como Baterías (aplicable en los países que han adoptado sistemas de recogida selectiva de residuos)

Si desea deshacerse de este producto, no lo mezcle con los residuos generales de su hogar. Existe un sistema de recogida selectiva para aparatos electrónicos usados de acuerdo a la legislación, que requiere un tratamiento adecuado de recuperación y reciclado. Póngase en contacto con las autoridades locales para obtener más información sobre el punto de recogida y tratamiento más cercano. El apropiado reciclado y eliminación de residuos ayuda a conservar los recursos y a contribuir en la prevención de los efectos negativos y perjudiciales sobre nuestra salud y el medio ambiente.

FRANCAIS

Information sur le traitement des Déchets Electriques et Electroniques (DEEE), pour les pays ayant adopté un traitement séparés de ces déchets

Si vous possédez des appareils Electriques ou Electroniques usagés, ne les jetez pas dans le système général. Conformément à la Directive Européenne, transposée dans votre pays, il existe un système séparé de recyclage et de traitement de ces déchets. Veuillez contacter l'administration locale afin de prendre connaissance du lieu de recyclage et de traitement le plus proche de chez vous. Ce système est destiné à protéger l'environnement.



ENGLISH

Introduction:

Please read this OWNER'S MANUAL thoroughly to familiarize yourself with each control and function. We at ALPINE hope that your new KTA-200M will give you many years of listening enjoyment.

In case of problems when installing your KTA-200M, please contact your authorized ALPINE dealer.

CAUTION: These controls are for tuning your system. Please consult your authorized Dealer for adjustment.

 WARNING	This symbol means important instructions. Failure to heed them can result in serious injury or death.
 CAUTION	This symbol means important instructions. Failure to heed them can result in injury or property damages.

WARNING

- **DO NOT OPERATE ANY FUNCTION THAT TAKES YOUR ATTENTION AWAY FROM SAFELY DRIVING YOUR VEHICLE.** Any function that requires your prolonged attention should only be performed after coming to a complete stop. Always stop the vehicle in a safe location before performing these functions. Failure to do so may result in an accident.
- **KEEP THE VOLUME AT A LEVEL WHERE YOU CAN STILL HEAR OUTSIDE NOISES WHILE DRIVING.** Excessive volume levels that obscure sounds such as emergency vehicle sirens or road warning signals (train crossings, etc.) can be dangerous and may result in an accident. LISTENING AT LOUD VOLUME LEVELS IN A CAR MAY ALSO CAUSE HEARING DAMAGE.
- **DO NOT DISASSEMBLE OR ALTER.** Doing so may result in an accident, fire or electric shock.
- **USE THIS PRODUCT FOR MOBILE 12V APPLICATIONS.** Use for other than its designed application may result in fire, electric shock or other injury.
- **DO NOT BLOCK VENTS OR RADIATOR PANELS.** Doing so may cause heat to build up inside and may result in fire.
- **MAKE THE CORRECT CONNECTIONS.** Failure to make the proper connections may result in fire or product damage.
- **USE ONLY IN VEHICLES WITH A 12 VOLT NEGATIVE GROUND.** (Check with your dealer if you are not sure.) Failure to do so may result in fire, etc.
- **BEFORE WIRING, DISCONNECT THE CABLE FROM THE NEGATIVE BATTERY TERMINAL.** Failure to do so may result in electric shock or injury due to electrical shorts.
- **DO NOT ALLOW CABLES TO BECOME ENTANGLED IN SURROUNDING OBJECTS.** Arrange wiring and cables in compliance with the manual to prevent obstructions when driving. Cables or wiring that obstruct or hang up on places such as the steering wheel, gear lever, brake pedals, etc. can be extremely hazardous.
- **DO NOT SPLICE INTO ELECTRICAL CABLES.** Never cut away cable insulation to supply power to other equipment. Doing so will exceed the current carrying capacity of the wire and result in fire or electric shock.
- **DO NOT DAMAGE PIPE OR WIRING WHEN DRILLING HOLES.** When drilling holes in the chassis for installation, take precautions so as not to contact, damage or obstruct pipes, fuel lines, tanks or electrical wiring. Failure to take such precautions may result in fire.
- **DO NOT USE BOLTS OR NUTS IN THE BRAKE OR STEERING SYSTEMS TO MAKE GROUND CONNECTIONS.** Bolts or nuts used for the brake or steering systems (or any other safety-related system), or tanks should NEVER be used for installations or ground connections. Using such parts could disable control of the vehicle and cause fire etc.
- **KEEP SMALL OBJECTS SUCH AS BOLTS OR SCREWS OUT OF THE REACH OF CHILDREN.** Swallowing them may result in serious injury. If swallowed, consult a physician immediately.

CAUTION

- **HALT USE IMMEDIATELY IF A PROBLEM APPEARS.** Failure to do so may cause personal injury or damage to the product. Return it to your authorized Alpine dealer or the nearest Alpine Service Center for repairing.
- **HAVE THE WIRING AND INSTALLATION DONE BY EXPERTS.** The wiring and installation of this unit requires special technical skill and experience. To ensure safety, always contact the dealer where you purchased this product to have the work done.
- **USE SPECIFIED ACCESSORY PARTS AND INSTALL THEM SECURELY.** Be sure to use only the specified accessory parts. Use of other than designated parts may damage this unit internally or may not securely install the unit in place. This may cause parts to become loose resulting in hazards or product failure.
- **ARRANGE THE WIRING SO IT IS NOT CRIMPED OR PINCHED BY A SHARP METAL EDGE.** Route the cables and wiring away from moving parts (like the seat rails) or sharp or pointed edges. This will prevent crimping and damage to the wiring. If wiring passes through a hole in metal, use a rubber grommet to prevent the wire's insulation from being cut by the metal edge of the hole.
- **DO NOT INSTALL IN LOCATIONS WITH HIGH MOISTURE OR DUST.** Avoid installing the unit in locations with high incidence of moisture or dust. Moisture or dust that penetrates into this unit may result in product failure.

SERVICE CARE

◆ **IMPORTANT NOTICE**

This Amplifier has been type tested and found to comply with the limits for a Class B computing device in accordance with the specifications in Subpart J of Part 15 of FCC Rules. This equipment generates and uses radio frequency energy, and it must be installed and used properly in accordance with the manufacturer's instructions.

◆ **For European Customers**

Should you have any questions about warranty, please consult your store of purchase.

◆ **For Customers in other Countries**

IMPORTANT NOTICE

Customers who purchase the product with which this notice is packaged, and who make this purchase in countries other than the United States of America and Canada, please contact your dealer for information regarding warranty coverage.

SERIAL NUMBER:	_____
INSTALLATION DATE:	_____
INSTALLATION TECHNICIAN:	_____
PLACE OF PURCHASE:	_____

◆ **IMPORTANT**

Please record the serial number of your unit in the space provided here and keep it as a permanent record. The serial number plate is located on the rear of the unit.

SPECIFICATIONS

Power Output	Ref: 14.4V, 4Ω, @ ≤1% THD+N	200W RMS x 1
	Ref: 14.4V, 2Ω, @ ≤1% THD+N	200W RMS x 1
DPP(Dynamic Peak Power) Output	Ref: 14.4V, 4Ω, @ ≤1% THD+N	400W RMS x 1
	Ref: 14.4V, 2Ω, @ ≤1% THD+N	400W RMS x 1
THD+N	Ref: 10W into 4Ω	<0.2% THD+N
	Ref: Rated Power into 4Ω	<0.1% THD+N
	Ref: 10W into 2Ω	<0.1% THD+N
	Ref: Rated Power into 2Ω	<0.1% THD+N
S/N Ratio	AES-17, Ref: 1 W into 4Ω	> 85dB
	AES-17, Ref: Rated Power into 4Ω	> 95dB
Frequency Response	+0 / -3 dB, Ref: 1 W into 4Ω	20-400Hz
Input Sensitivity	Ref: Rated Power into 4Ω, RCA	0.2-4.0V
Crossover	Selectable Low Pass Filter	OFF/60/80/120Hz
Dimensions	Width	89mm (3-1/2")
	Height (inches) [with universal bracket]	36mm (1-7/16") [39mm]
	Length (inches) [with universal bracket]	181mm (7-1/8") [198mm]
Weight		0.6kg (1.3lbs)

NOTE:

- Product improvements and specification are subject to change with out notice.

ACCESSORIES

- Input/Output/Power Wire Harness 1
- Universal bracket set; 1 left & 1 right 1ea
- W650 mounting bracket with mounting screws, button head 4
- Cable Tie 4
- Self Tapping screw 4
- W650 bracket to HU screws, M2.6 x 8mm 2

CONNECTIONS (Fig. 1)

Before making connections, be sure to turn the power off to all audio components. Connect the yellow battery lead from the amp directly to the positive (+) terminal of the vehicle's battery. Do not connect this lead to the fuse block.

⚠ CAUTION

◆ Caution on connection terminals/parts

- Keep electrically conductive objects away from the unit's terminals/parts (power terminals, fuses, speaker output terminals, RCA connectors, etc.). Doing so prevents a possible short circuit and damage to the unit.
- Use appropriate electrical source. The person installing this will choose the appropriate electrical source.

To prevent external noise from entering the audio system.

- Locate the unit and route the leads at least 10 cm (3-15/16") away from the car harness.
- Keep the battery power leads as far away from other leads as possible.
- Connect the ground lead securely to a bare metal spot (remove any paint or grease if necessary) of the car chassis.
- Your Alpine dealer knows best about noise prevention measures so consult your dealer for further information.

① Input/Output/Power Connector

② Input/Output/Power Wire Harness

③ Subwoofer Output Leads

Be sure to observe correct subwoofer output connections in the system. Connect the positive output (+) to the positive subwoofer terminal and the negative output (-) to the negative subwoofer terminal.

Note:

- Do not connect subwoofer leads together or to chassis ground.

④ Input Signal Leads

RCA Input Jacks

Connect these jacks to the line out leads on your head unit, you may or may not require extension cable.

⑤ Ground Lead (Black)

Connect this lead securely to a clean, bare metal spot on the vehicle's chassis. Verify this point to be a true ground by checking for continuity between that point and the negative (-) terminal of the vehicle's battery. Ground all your audio components to the same point on the chassis to prevent ground loops.

⑥ Battery Lead (Yellow)

Connect battery lead directly to BATT +

Be sure to add a 20A fuse (sold separately) as close as possible to the battery's (+) terminal.

⑦ Remote Turn-On Lead (Blue/White)

Connect this lead to the remote turn-on or power antenna (positive trigger, (+) 12V only) lead of your head unit.

⑧ Remote Bass Level Connector

Connect this lead to Alpine's remote control bass knob (RUX-KNOB.2 sold separately)

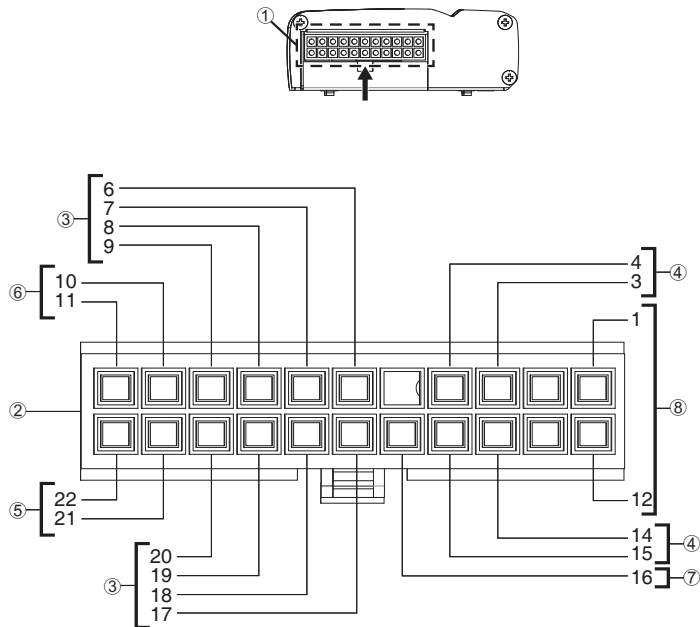

Pin	Color	function
1	Black	Rem Bass Control, (-)
2	NC	
3	Black	Audio Input, front right (-)
4	Black	Audio Input, front left (-)
5	NC	
6	Brown / black	Audio Output, Subwoofer (-)
7	Brown / black	Audio Output, Subwoofer (-)
8	Brown / black	Audio Output, Subwoofer (-)
9	Brown / black	Audio Output, Subwoofer (-)
10	Yellow	Battery, Positive leads
11	Yellow	Battery, Positive leads
12	Black / Gray	Rem Bass Control, (+)
13	NC	
14	Black / red	Audio Input, front right (+)
15	Black / white	Audio Input, front left (+)
16	Blue / white	Remote on
17	Brown	Audio Output, Subwoofer (+)
18	Brown	Audio Output, Subwoofer (+)
19	Brown	Audio Output, Subwoofer (+)
20	Brown	Audio Output, Subwoofer (+)
21	Black	Ground
22	Black	Ground

Fig. 1

KTA-200M Left side panel/Panneau de gauche/Panel izquierdo

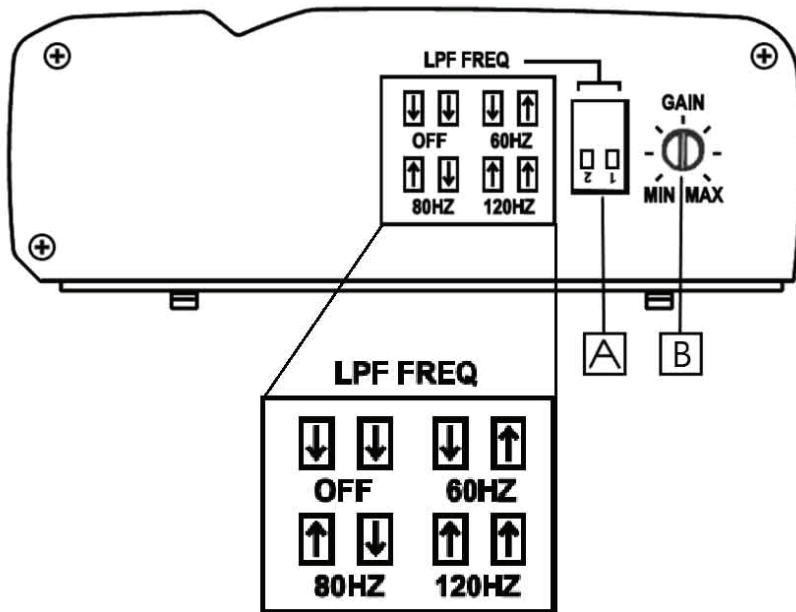
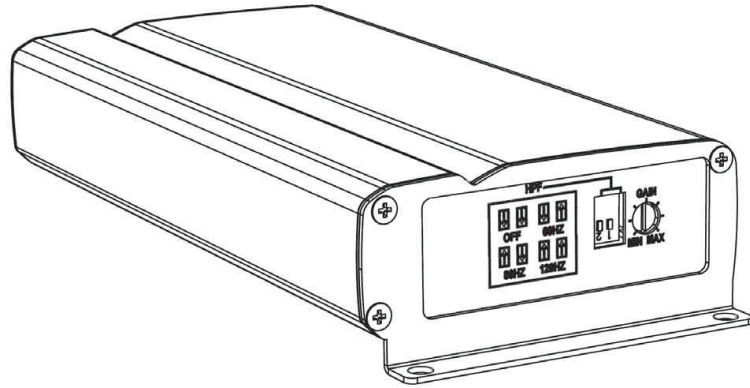





Fig. 2

SWITCH SETTINGS (Fig. 2)

- ⑨ **Gain Setting**
Set the KTA-200M input gain to the minimum position. Using a dynamic CD as a source, increase the head unit volume until the output distorts. Then, reduce the volume 1 step (or until the output is no longer distorted). Now, increase the amplifier gain until the sound from the subwoofer becomes distorted. Reduce the gain slightly so the sound is no longer distorted to achieve the optimum gain setting.
- ⑩ **Low Pass Filter Selector Switches**
Switch number 1 and 2 are for low pass filter settings. Default setting for low pass filter is off.

Control section	Switch number	Function
A	1 & 2	Filter configuration
B	N/A	Gain control

FILTER Configuration **A** :

-  Filter off position: Switch 2 and 1 down.
OFF
-  Filter is set for 60Hz low pass; switch 2 down and 1 is up.
60HZ
-  Filter is set for 80Hz low pass; switch 2 up and 1 is down.
80HZ
-  Filter is set for 120Hz low pass; switch 2 up and 1 is up.
120HZ

Function	Switch number & position
LPF off	2 down & 1 down
LPF 60Hz	2 down & 1 up
LPF 80Hz	2 up & 1 down
LPF 120Hz	2 up & 1 up

Gain control **B** :

This control is for input voltage sensitivity adjustment to allow use with various signal sources with RCA level subwoofer outputs.

1. Full rated output is obtained with the appropriate settings.
2. Distortion can be had when the gain control is set incorrectly.

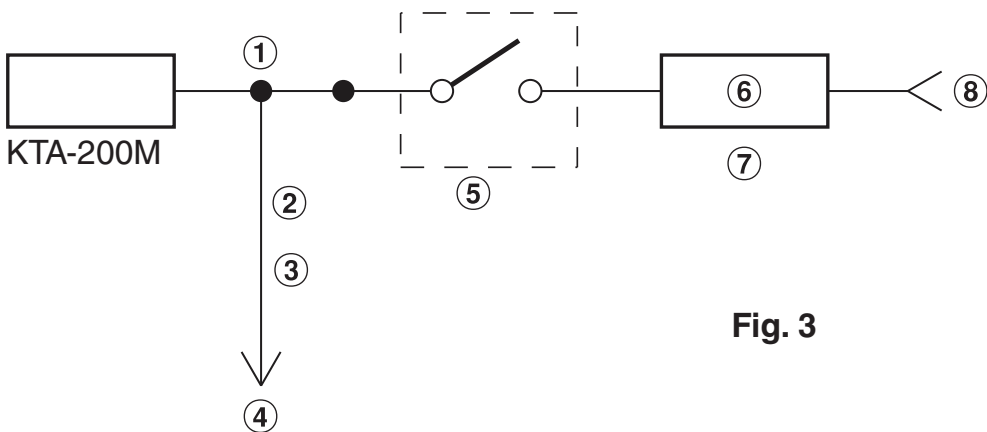

Fig. 3

ALTERNATIVE AMPLIFIER TURN-ON OPTIONS (Fig. 3)

If your head unit does not have a traditional amplifier turn-on lead, refer to the options below for connection.

Please check your head unit for the conditions listed below: (Fig. 3)

- The head unit does not have a remote turn-on or power antenna lead.
- The head unit's power antenna lead is activated only when the radio is on (turns off in Bluetooth or CD mode).
- The head unit's power antenna lead is logic level output (+) 5V, negative trigger (grounding type), or cannot sustain (+) 12V when connected to other equipment in addition to the vehicle's power antenna. If any of the above conditions exist, the remote turn-on lead of your KTA-200M must be connected to a switched power source (ignition) in the vehicle. Be sure to use a 3A fuse as close as possible to this ignition tap. Using this connection method, the KTA-200M will turn on and stay on as long as the ignition switch is on.

If this is objectionable, a SPST (Single Pole, Single Throw) switch, in addition to the 3A fuse mentioned above, may be installed in-line on the KTA-200M turn-on lead. This switch will then be used to turn on (and off) the KTA-200M. Therefore, the switch should be mounted so that is accessible by the driver. Make sure the switch is turned off when the vehicle is not running. Otherwise, the amplifier will remain on and drain the battery.

- ① Blue/White
- ② Power Antenna
- ③ Remote Turn-On Lead
- ④ To other Alpine components' Remote Turn-On Leads
- ⑤ SPST Switch (optional)
- ⑥ Fuse (3A)
- ⑦ As close as possible to the vehicle's ignition tap
- ⑧ Ignition Source

TYPICAL SYSTEM CONNECTIONS/CONNEXIONS TYPIQUES DU SYSTEME/CONEXIONES TIPICAS DEL SISTEMA

RCA Input System/Système d'entrée RCA/Sistema de entrada RCA

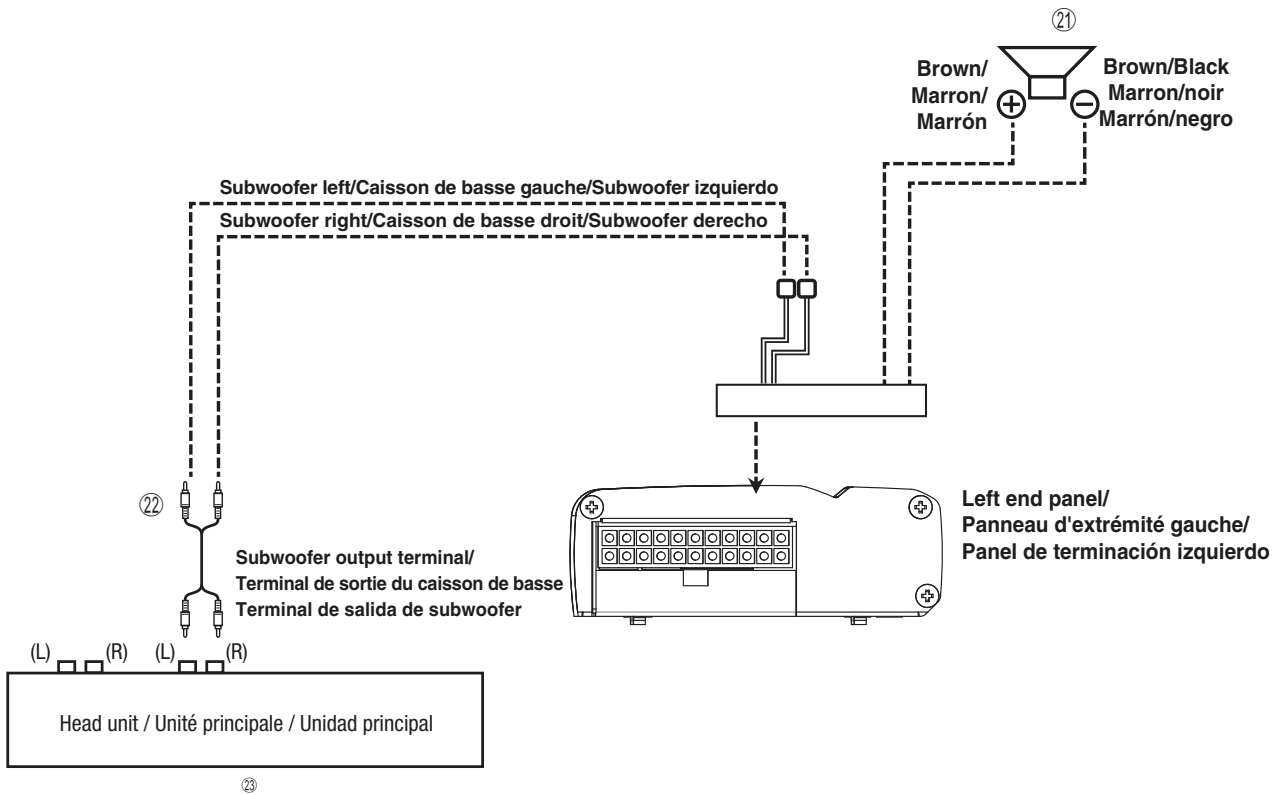

Fig. 4

[English]

- ① Subwoofer (sold separately)
- ② RCA Extension Cable (sold separately)
- ③ Head Unit

[Français]

- ① Caisson de basse (vendu séparément)
- ② Câble d'extension RCA (vendu séparément)
- ③ Unité principale

[Español]

- ① Subwoofer (a la venta por separado)
- ② Cable de extensión RCA (se vende por separado)
- ③ Unidad principal

Assembly of;

1. HU bracket to amp.

- a. Attach bracket to amp; use the 4 black button head screws included. Tighten with 3mm hex tool.
- b. Place button head screws in place and tighten to be snug.
- c. Secure the screw by tightening just about ¼ turn more.
- d. Follow diagram below.

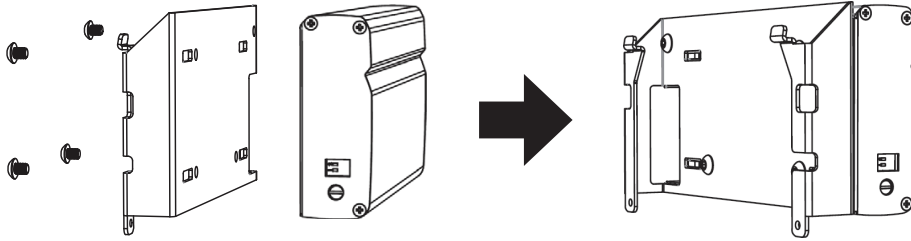

2. HU bracket connected to HU

- a. Remove the 2 bottom corner screws from HU and place to the side. These are not used.
 - i. Use the 8mm screws in the kit. These replace the short screws removed from the HU and placed to the side.
- b. The attachment process is to insert the assembled amp and its bracket with two tabs into their slot on the upper portion of radio rear panel. Pivot down. See below image: Mount point A

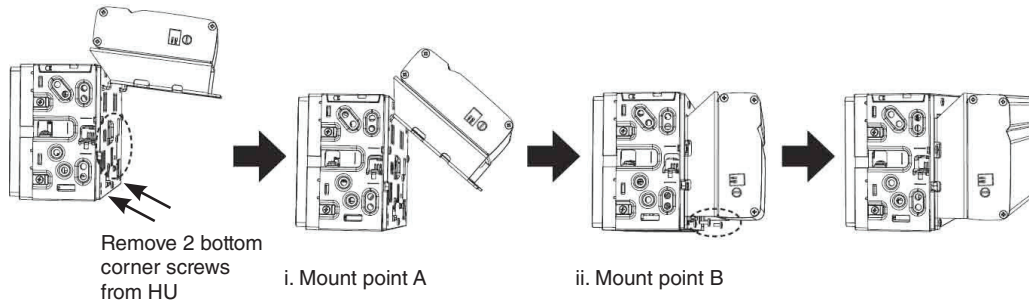

- c. Move antenna cable to the cut out space and then finish pivoting the amp to make contact.
- d. Replace the 2 screws. Do not use an electric screw gun, you will strip it. See above image: Mount point B.

3. Universal bracket to amp.

- a. Each end gets a unique bracket.
- b. Remove 3 Philips screws from end panels, do not lose these.

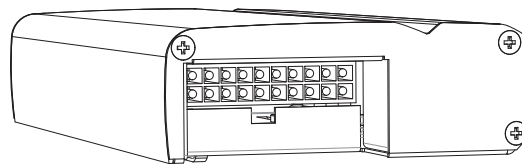

- c. Place each bracket so that the 3 holes are visible and aligned.
 - i. For the switch control side the silk screen will be completely visible.
 - ii. Re use the 3 screws and replace. This will fix the bracket in place.
 - iii. Tighten to snug plus 1/8 turn to be tight.
 - iv. Repeat for opposite side.

- d. Completed side:

