



INTERFACE COMPONENTS

- AXDSPX-MI2 interface
- AXDSPX-MI2 interface harness
- AXDSPX-MI2 vehicle T-harness • Bass knob
- AXDSPX-MI2 display T-harness

APPLICATIONS

Visit AxessInterfaces.com for current application list

For **Dash Disassembly Instructions**, refer to metraonline.com. Enter the year, make, and model of the vehicle in the **Vehicle Fit Guide** for **Radio Install kits**.



DSP Data Interface with Pre-Wired Harness

Fits Select Mitsubishi Models 2007-2020

INTERFACE FEATURES

- Designed for non-amplified systems
- Selectable 31-band Graphic EQ or 5-band parametric EQ on each channel with high pass, low pass, and bandpass filters
- 6 inputs and 10 individually assignable outputs
- Selectable slope (12, 24, 36, or 48db per octave)
- Selectable Graphic or Parametric EQ
- Independent equalization on each of the 10 outputs
- Each channel can be delayed independently up to 10 ms
- Clipping detection and limiting circuits
- Bass knob included
- Settings adjusted wirelessly in the free AX-DSP-XL app available for smartphones and tablets
- Easy behind the radio installation
- Can be used with factory and aftermarket radios
- Read, write, and store configurations for future recall
- Password protect feature available in the app
- Micro “B” USB updatable

TABLE OF CONTENTS

Installation & Installation Options.....	2
Connections.....	3-4
Mobile App: Quick Setup.....	5-6
Specifications.....	7

TOOLS & INSTALLATION ACCESSORIES REQUIRED

- Crimping tool and connectors, or solder gun, solder, and heat shrink • Tape • Wire cutter
- Zip-ties • Multimeter tester

Download AX-DSP-XL App

Android™ 9 or higher



iOS® 12.1 or higher



ATTENTION: With the key out of the ignition, disconnect the negative battery terminal before installing this product. Ensure that all installation connections, especially the air bag indicator lights, are plugged in before reconnecting the battery or cycling the ignition to test this product.

NOTE: Refer also to the instructions included with the aftermarket accessory before installing this device.

INSTALLATION OPTIONS

Adding a subwoofer to a factory system:

The diagram on **Page 3** shows the connections that need to be made to add a subwoofer to the factory system.

Note: RCA jacks sold separately.)

Adding a full-range of amps and subwoofer to a factory system:

The diagram on **Page 4** shows the connections that need to be made to add: Subwoofer (RCA jacks sold separately)

Amplifier (SPDT relay E-123 required) or Additional Amp (RCA jacks sold separately).

Note: The interface provides a 12-volt 1-amp output to turn on aftermarket amp(s). If installing multiple amps, an SPDT automotive relay will be required if the amp turn-on current of all amps combined exceeds 1-amp. Use Metra part number E-123 (sold separately) for best results.

INSTALLATION

1. Disassemble the dash, unplug all connectors, and then remove the factory radio.*
2. Install the **AXDSPX-MI2 vehicle T-harness** to the vehicle and make all necessary connections, but leave the amp turn-on wire disconnected.
3. Plug the **AXDSPX-MI2 vehicle T-harness** to the **AXDSPX-MI2 interface**.
4. Plug the **AXDSPX-MI2 interface harness** to the **AXDSPX-MI2 interface**.
5. Download and install the **AX-DSP-XL app** for your smart device.
6. Open the app then select the **Bluetooth Connection** tab. Follow the instructions to pair the mobile device to the interface. Refer to **Page 5** for more information.
7. Scroll to the **Configuration** tab then select the vehicle type. Press the **Lock Down**** button to save the configuration. Refer to **Page 6** for more information.
8. Connect the amp turn-on wire.
9. Adjust the settings in the app as desired. Press the **Lock Down**** button to save any new configurations.

* For dash disassembly instructions, refer to metraonline.com Enter the year, make, and model of the vehicle in the Vehicle Fit Guide and find instructions under Metra Radio Install kits.

** Anytime the interface is locked down the key must be cycled off then back on.

ADDING A SUBWOOFER TO A FACTORY SYSTEM

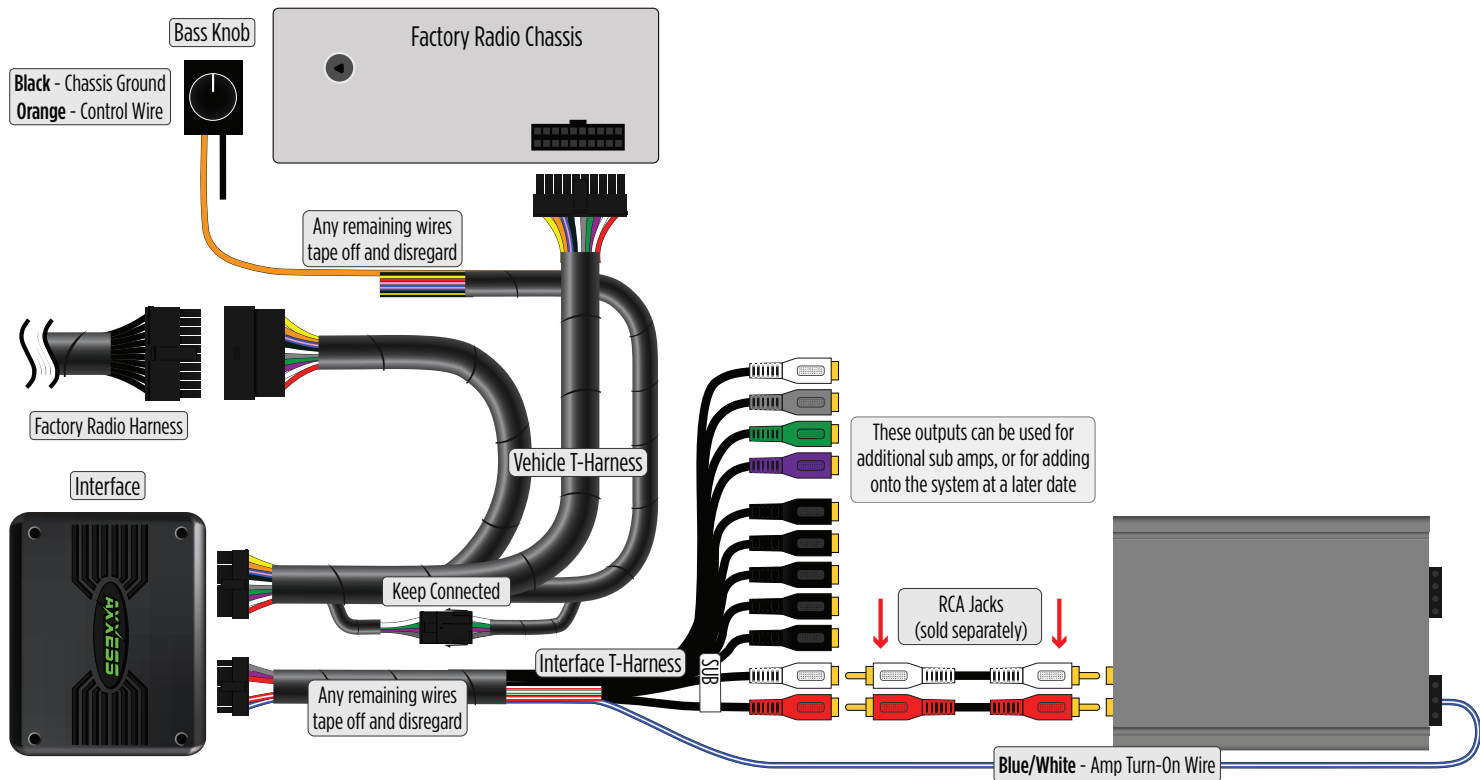

ADDING A FULL-RANGE AMPLIFIER & SUBWOOFER TO A FACTORY SYSTEM

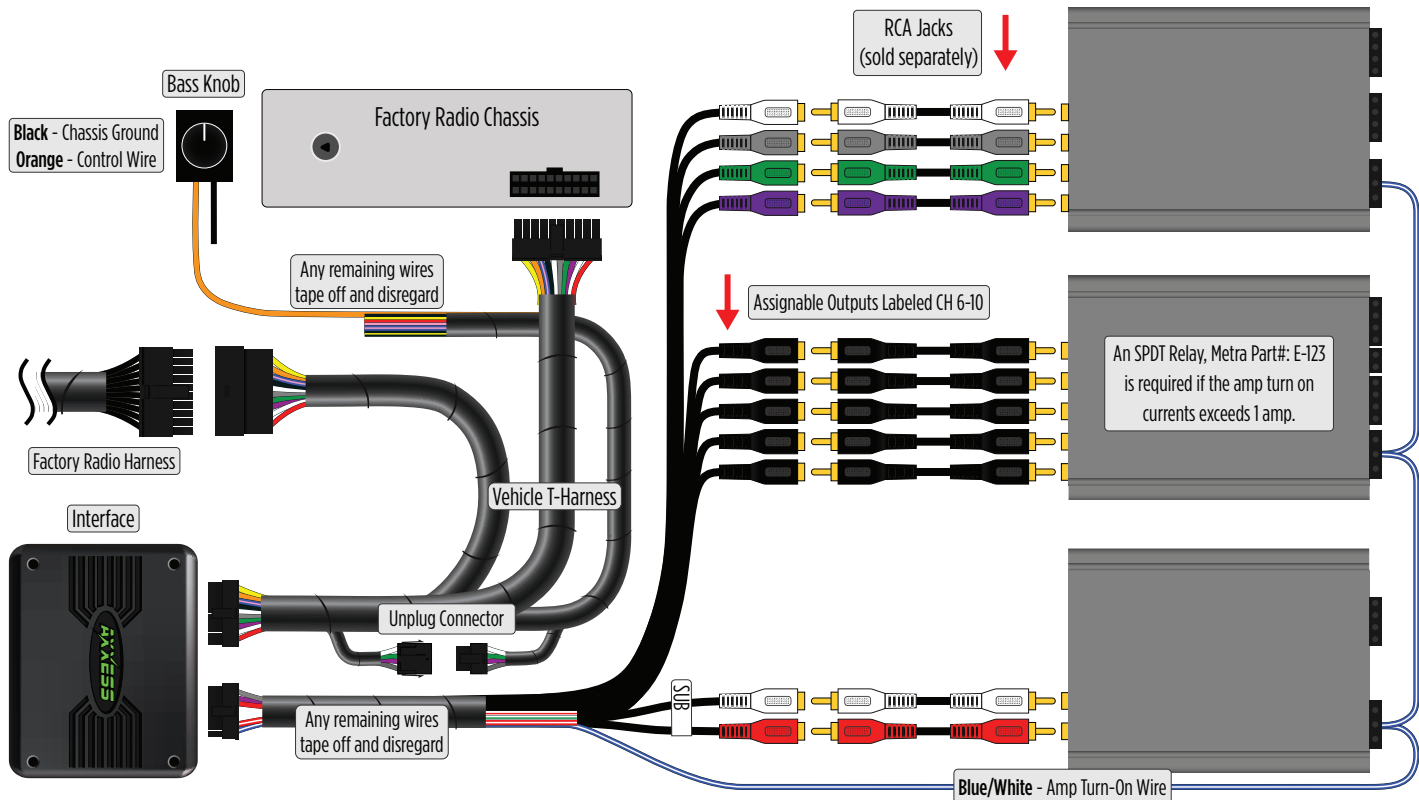

MOBILE APP: QUICK SETUP STEPS THROUGH AXDSP-XL APP

Android™ 9 or higher



iOS® 12.1 or higher



1. Download and install the **AX-DSP-XL app** for your smart device.
2. Turn Vehicle Ignition on. Make sure the Remote Turn on lead is disconnected.
3. Open the app: Select **Bluetooth Connections** page.
 - Select **Scan**, all available AXDSP devices within range will be displayed. Select your AXDSP and hit connect. (Figure A)
4. Select the Configuration page.
 - Select **Vehicle Type** Icon
 - Select the Vehicle Make: ____ (Example: **MITSUBISHI**)
 - Select the Vehicle's model: ____ (Example: **MONTERO**)
 - Select **Without OE Amp**
 - Hit **Apply** (Figure B)
5. Make sure radio volume is all the way down.
6. Connect the amp turn-on wire from the **AXDSPX-M12 T-harness** to the aftermarket amplifiers.



(Figure A)

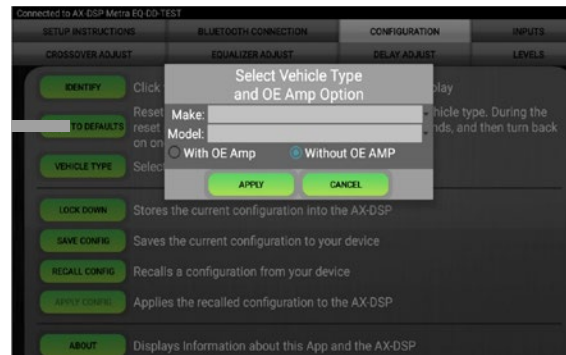

(Figure B)

Continued on the next page

MOBILE APP: QUICK SETUP STEPS THROUGH AXDSP-XL APP (CONT.)

- From the **Configuration** page click the **Identify** button to confirm that the **AXDSPX-M12** is connected properly. If so, a chime will be heard from the front left speaker.
- Press the **Lock Down** button to save the configuration. (Do not turn ignition off until this process is completed) (Figure C)
- Select the **Bluetooth Configurations** page and disconnect the DSPX.
- Turn ignition off, close all door then lock vehicle using the key fob. The vehicle will need to sit uninterrupted for 10 minutes while the vehicle goes to sleep. (Make sure Key fob is 15 feet away from the vehicle)
- Unlock Vehicle, turn ignition on and test radio's functions.
- Adjust the DSP settings in the app as desired. Refer to the instructions under the **Setup Instructions** tab, or online at Axxessinterfaces.com for an explanation of each tab in the app.

Locking Down Data

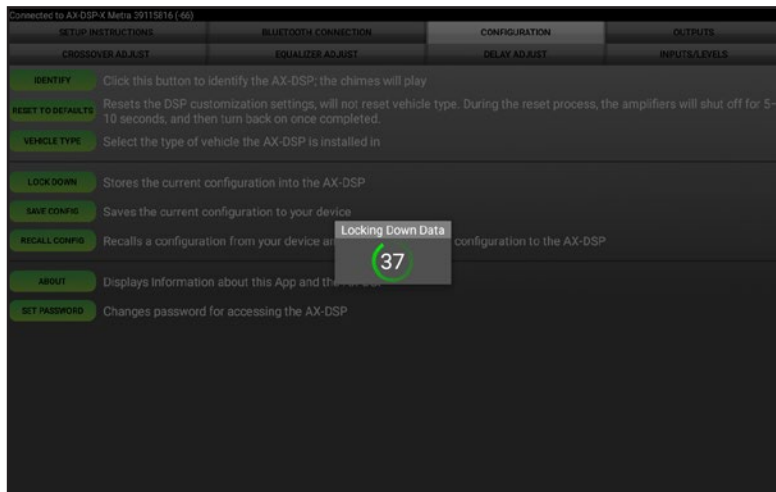

(Figure C)

**Last and the most important:
You MUST lock down your
configuration and cycle the key!!!**

SPECIFICATIONS

Specifications

Input Impedance	1M Ohm
Input Channels	6 High/Low level Selectable
Input Options	High Level or Low Level
Input Type	Differential-Balanced
Input Voltage	
High Level Range	0 - 28v Peak to Peak
Low Level Range	0 - 4.9v Peak to Peak
Output Channels	10
Output Voltage	Up to 5v RMS
Output Impedance	50 Ohms
Equalizer Type	31 Band Graphic EQ, +/- 10dB
THD	<0.03%
Frequency Response	20Hz - 20kHz
Crossover	3-Way LPF, BPF, HPF THP per channel
Crossover Type	Linkwitz-Riley 24DB Slope, Fixed
Sampling	48kHz
S/N Ratio	105dB @ 5V RMS

General

Operating Voltage	10 - 16VDC
Standby Current Draw	~7mA
Operation Current Draw	~150mA
Adjustments/Controls	Application via Bluetooth
Remote Output	12VDC, Signal Sense or with Ignition



AXDSPX-M12

INSTALLATION INSTRUCTIONS

Having difficulties? We're here to help.



Contact our Tech Support line at:

386-257-1187



Or via email at:

techsupport@metra-autosound.com

Tech Support Hours (Eastern Standard Time)

Monday - Friday: 9:00 AM - 7:00 PM

Saturday: 10:00 AM - 5:00 PM

Sunday: 10:00 AM - 4:00 PM



**Metra recommends MECP
certified technicians**