

KICKER® MWLE10

Loaded Premium Marine Subwoofer Enclosure



Info Card | Tarjeta de Información | Carte Info | Infokarte

IMPORTANT: KICKER recommends a professional installation performed by authorized retailers. You are solely responsible for safely mounting and wiring your products.

IMPORTANTE: KICKER recomienda que se realice una instalación profesional con proveedores con licencia. Usted es el único responsable por la instalación segura y el cableado de sus productos.

IMPORTANT : KICKER recommande une installation professionnelle effectuée par des fournisseurs agréés. Vous êtes l'unique responsable du montage et du câblage de vos produits en toute sécurité.

WICHTIG: KICKER empfiehlt eine professionelle Montage durch lizenzierte Anbieter. Sie haben die alleinige Verantwortung für die sichere Montage und Verkabelung Ihrer Geräte.



Scan here for
product page
Escanee aquí para
página del producto



Scannez ici pour
fiche produit
Scannen Sie hier nach
Produktseite

CAUTION: KICKER PRODUCTS CAN PRODUCE SOUND LEVELS THAT CAN PERMANENTLY DAMAGE YOUR HEARING! TURNING UP A SYSTEM TO A LEVEL THAT HAS AUDIBLE DISTORTION IS MORE DAMAGING TO YOUR EARS THAN LISTENING TO AN UNDISTORTED SYSTEM AT THE SAME VOLUME LEVEL. THE THRESHOLD OF PAIN IS ALWAYS AN INDICATOR THE SOUND LEVEL IS TOO LOUD AND MAY PERMANENTLY DAMAGE YOUR HEARING. PLEASE USE COMMON SENSE WHEN CONTROLLING VOLUME.

ADVERTENCIA: LOS EXCITADORES KICKER SON CAPACES DE PRODUCIR NIVELES DE SONIDO QUE PUEDEN DAÑAR PERMANENTEMENTE EL OÍDO. SUBIR EL VOLUMEN DEL SISTEMA HASTA UN NIVEL QUE PRODUZCA DISTORSIÓN ES MÁS DAÑINO PARA EL OÍDO QUE ESCUCHAR UN SISTEMA SIN DISTORSIÓN AL MISMO VOLUMEN. EL DOLOR ES SIEMPRE UNA INDICACIÓN DE QUE EL SONIDO ES MUY FUERTE Y QUE PUEDE DAÑAR PERMANENTEMENTE EL OÍDO. SEA PRECAVIDO CUANDO CONTROLE EL VOLUMEN.

AVERTISSEMENT: LES HAUT-PARLEURS KICKER ONT LA CAPACITÉ DE PRODUIRE DES NIVEAUX SONORES POUVANT ENDOMMAGER L'OUÏE DE FAÇON IRRÉVERSIBLE ! L'AUGMENTATION DU VOLUME D'UN SYSTÈME JUSQU'À UN NIVEAU PRÉSENTANT UNE DISTORSION AUDIBLE ENDOMMAGE D'AVANTAGE L'OUÏE QUE L'ÉCOUTE D'UN SYSTÈME SANS DISTORSION AU MÊME VOLUME. LE SEUIL DE LA DOULEUR EST TOUJOURS LE SIGNE QUE LE NIVEAU SONORE EST TROP ÉLEVÉ ET RISQUE D'ENDOMMAGER L'OUÏE DE FAÇON IRRÉVERSIBLE. RÉGLEZ LE VOLUME EN FAISANT PREVUE DE BON SENS !

WARNUNG: KICKER-TREIBER KÖNNEN EINEN SCHALLPEGEL ERZEUGEN, DER ZU PERMANENTEN GEHÖRSCHÄDEN FÜHREN KANN! WENN SIE EIN SYSTEM AUF EINEN PEGEL STELLEN, DER HÖRBARE VERZERRUNGEN ERZEUGT, SCHADET DAS IHREN OHREN MEHR, ALS EIN NICHT VERZERRTES SYSTEM AUF DEM GLEICHEN LAUTSTÄRKEPEGEL. DIE SCHMERZSCHWELLE IST IMMER EINE ANZEIGE DAFÜR, DASS DER SCHALLPEGEL ZU LAUT IST UND ZU PERMANENTEN GEHÖRSCHÄDEN FÜHREN KANN. SEIEN SIE BEI DER LAUTSTÄRKEEINSTELLUNG BITTE VERNÜNFTIG!

KICKER PRODUCTS ARE WARRANTED AGAINST DEFECTS. DURATION AND TERMS OF WARRANTY DEPEND ON THE LAWS IN THE COUNTRY IN WHICH IT WAS PURCHASED. FOR DETAILS SEE YOUR LOCAL KICKER DEALER OR WWW.KICKER.COM/WARRANTY.

OUR GOODS COME WITH GUARANTEES THAT CANNOT BE EXCLUDED UNDER THE AUSTRALIAN CONSUMER LAW. YOU ARE ENTITLED TO A REPLACEMENT OR REFUND FOR A MAJOR FAILURE AND FOR COMPENSATION FOR ANY OTHER REASONABLY FORESEEABLE LOSS OR DAMAGE. YOU ARE ALSO ENTITLED TO HAVE THE GOODS REPAIRED OR REPLACED IF THE GOODS FAIL TO BE OF ACCEPTABLE QUALITY AND THE FAILURE DOES NOT AMOUNT TO A MAJOR FAILURE.

LOS PRODUCTOS KICKER ESTÁN GARANTIZADOS CONTRA DEFECTOS. LA DURACIÓN Y LOS TÉRMINOS DE LA GARANTÍA DEPENDEN DE LAS LEYES DEL PAÍS EN DONDE SE REALIZÓ LA COMPRA. PARA MÁS DETALLES CONSULTE A SU DISTRIBUIDOR LOCAL DE KICKER O VISITE WWW.KICKER.COM/WARRANTY.

LES PRODUITS KICKER SONT GARANTIS CONTRE LES DÉFAUTS. LA DURÉE ET LES MODALITÉS DE LA GARANTIE DÉPENDENT DES LOIS DU PAYS DANS LEQUEL LE PRODUIT A ÉTÉ ACHETÉ. POUR PLUS D'INFORMATION VEUILLEZ VÉRIFIER AUPRÈS DE VOTRE DISTRIBUTEUR LOCAL KICKER OU VISITER LE SITE : WWW.KICKER.COM/WARRANTY.

KICKER-PRODUKTE HABEN EINE GARANTIE GEGEN MATERIAL- UND VERARBEITUNGSFEHLER. DAUER UND BEDINGUNGEN DER GARANTIE HÄNGEN VON DEN GESETZEN DES LANDES AB, IN DEM SIE ERWORBEN WURDEN. BZGL. EINZELHEITEN WENDEN SIE SICH BITTE AN IHREN ÖRTLICHEN KICKER-HÄNDLER ODER BESUCHEN SIE WWW.KICKER.COM/WARRANTY

Down-Firing

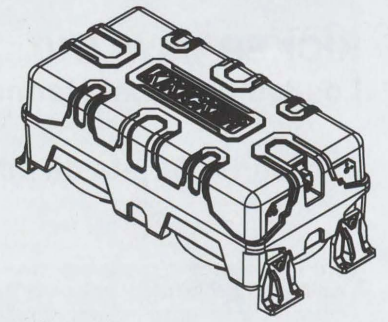
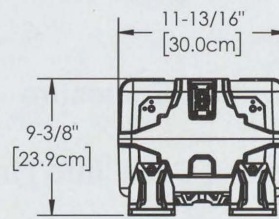
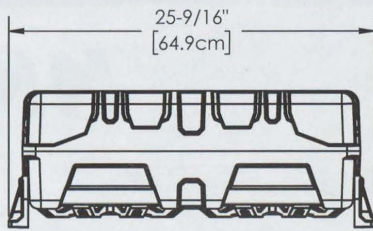

Forward-Firing

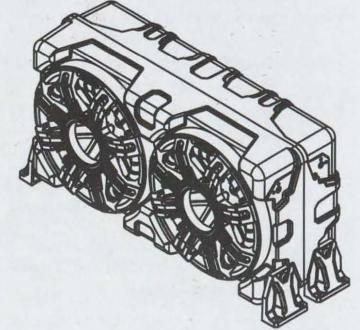
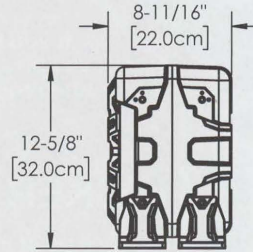
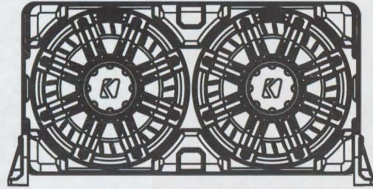

Up-Firing

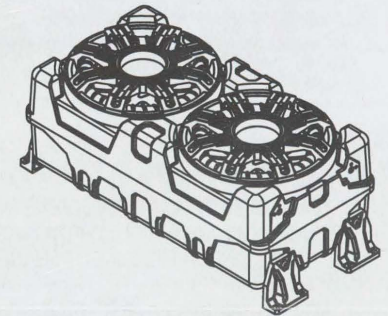
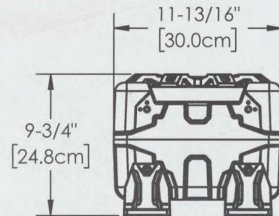
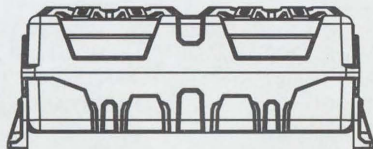

Wiring | Cabelado | Câblage | Verkabelung

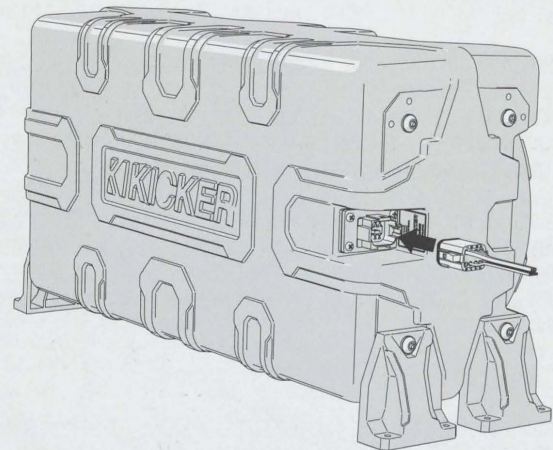
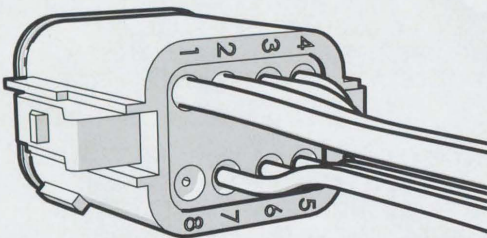

- 1. Speaker +
- 2. Speaker -
- 3. White LED (negative)
- 4. Blue LED (negative)
- 5. Red LED (negative)
- 6. Green LED (negative)
- 7. Black LED (positive)

- 1. Altavoz +
- 2. Altavoz -
- 3. LED blanco (negativo)
- 4. LED azul (negativo)
- 5. LED rojo (negativo)
- 6. LED verde (negativo)
- 7. LED negro (positivo)

Splice and combine the negative wires to yield a different color.
 Empalme y combine los cables de puesta a negativa para conseguir un color diferente.
 Raccorder et combiner les fils de prise de négative pour obtenir une couleur différente.
 Splicein und kombinieren Sie die negativen Drähte, um eine andere Farbe zu erhalten.

- 1. Haut-parleur +
- 2. Haut-parleur -
- 3. LED blanche (négatif)
- 4. LED bleue (négatif)
- 5. LED rouge (négatif)
- 6. LED verte (négatif)
- 7. LED noire (positive)

- 1. Lautsprecher +
- 2. Lautsprecher -
- 3. Weiße LED (negativ)
- 4. Blaue LED (negativ)
- 5. Rote LED (negativ)
- 6. Grüne LED (negativ)
- 7. Schwarze LED (positiv)

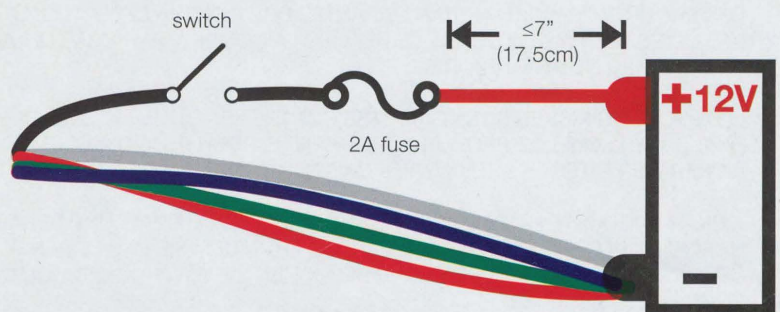

KICKER®

Owner's Manual
Manual del Propietario
Manuel d'utilisation
Benutzerhandbuch

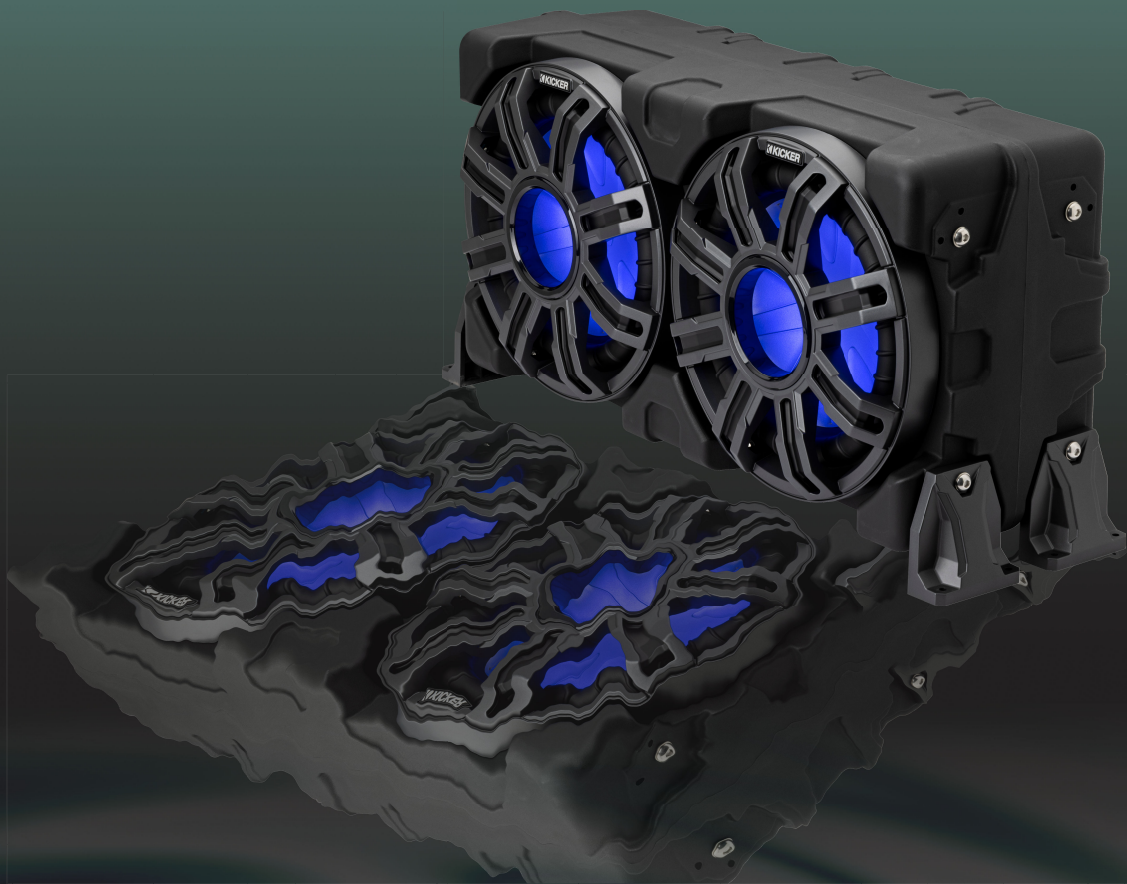

select language



MWLE10 Loaded Enclosure



*seleccione
el idioma*

MWLE10 Caja de Subwoofer

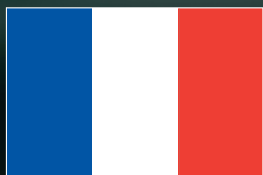

*choisir la
langue*

Caisson de Graves MWLE10



*sprache
auswählen*

MWLE10 Tieftönergehäuse

Contents

Overview	3
Specifications	4
Installation	5
Wiring Configuration.....	5
Mounting.....	8
Warranty	10
Garantía Garantie.....	

Overview

IMPORTANT SAFETY WARNING

PROLONGED CONTINUOUS OPERATION OF AN AMPLIFIER, SPEAKER, OR SUBWOOFER IN A DISTORTED, CLIPPED OR OVER-POWERED MANNER CAN CAUSE YOUR AUDIO SYSTEM TO OVERHEAT, POSSIBLY CATCHING FIRE AND RESULTING IN SERIOUS DAMAGE TO YOUR COMPONENTS AND/OR VEHICLE. AMPLIFIERS REQUIRE UP TO 4 INCHES (10CM) OPEN VENTILATION. SUBWOOFERS SHOULD BE MOUNTED WITH AT LEAST 1 INCH (2.5CM) CLEARANCE BETWEEN THE FRONT OF THE SPEAKER AND ANY SURFACE. KICKER PRODUCTS ARE CAPABLE OF PRODUCING SOUND LEVELS THAT CAN PERMANENTLY DAMAGE YOUR HEARING! TURNING UP A SYSTEM TO A LEVEL THAT HAS AUDIBLE DISTORTION IS MORE DAMAGING TO YOUR EARS THAN LISTENING TO AN UNDISTORTED SYSTEM AT THE SAME VOLUME LEVEL. THE THRESHOLD OF PAIN IS ALWAYS AN INDICATOR THAT THE SOUND LEVEL IS TOO LOUD AND MAY PERMANENTLY DAMAGE YOUR HEARING. PLEASE USE COMMON SENSE WHEN CONTROLLING VOLUME.

The KICKER Premium Marine MWLE Enclosure is a top-of-the-line sealed subwoofer enclosure packed with the kind of premium features required to dominate out on the water. The sub is made with weather-resistant Poly Cone & a Co-Molded TPE surround to ensure protection from the elements, which not only protects the woofer but produces highly-accurate bass & high power handling for maximum output. The enclosure is a rotomolded high-density polyethelene that is UV & Water-resistant, with all components built to be sealed from water, including the quick-connect plug. The passive ReFLEX Sub increases output and low-end extension, which is how you get such high-performance out of a small package. This high power-handling loaded sub box comes with lockable mounting feet & accessories which can be configured in an Up-, Down-, or Front-firing position. We hope you have the chance to combine this industry-defining sub enclosure with our whole line of new premium marine products, including speakers and amplifiers, for the best audio experience money can buy!

Specifications

<i>MWLE Sealed Enclosure</i>	<i>MWLE10</i>
Woofer [in, cm]	10, 25
Peak Power Handling [Watts]	800
Recommended Amplifier Power [Watts RMS]	200–400
Rated Impedance [Ω]	4
Frequency Response [Hz]	20–500
Tuning Frequency [Hz]	33
Sensitivity [1W, 1m]	88
Enclosure Depth [in, cm]	8-11/16, 22
Enclosure Height [in, cm]	9-3/4, 25
Enclosure Width [in, cm]	25-9/16, 65

Note: All specifications and performance figures are subject to change. Please visit **www.kicker.com** for the most current information. To get the best performance from your new KICKER speakers, we recommend using genuine KICKER accessories and wiring. Please allow two weeks of break-in time for the speakers to reach optimum performance.

Installation

Wiring Configuration

The MWLE was designed to provide the easiest install and cable management possible using a quick-connect plug that carries audio and LED lighting.

1. Connect the MWLE plug to the MWLE enclosure

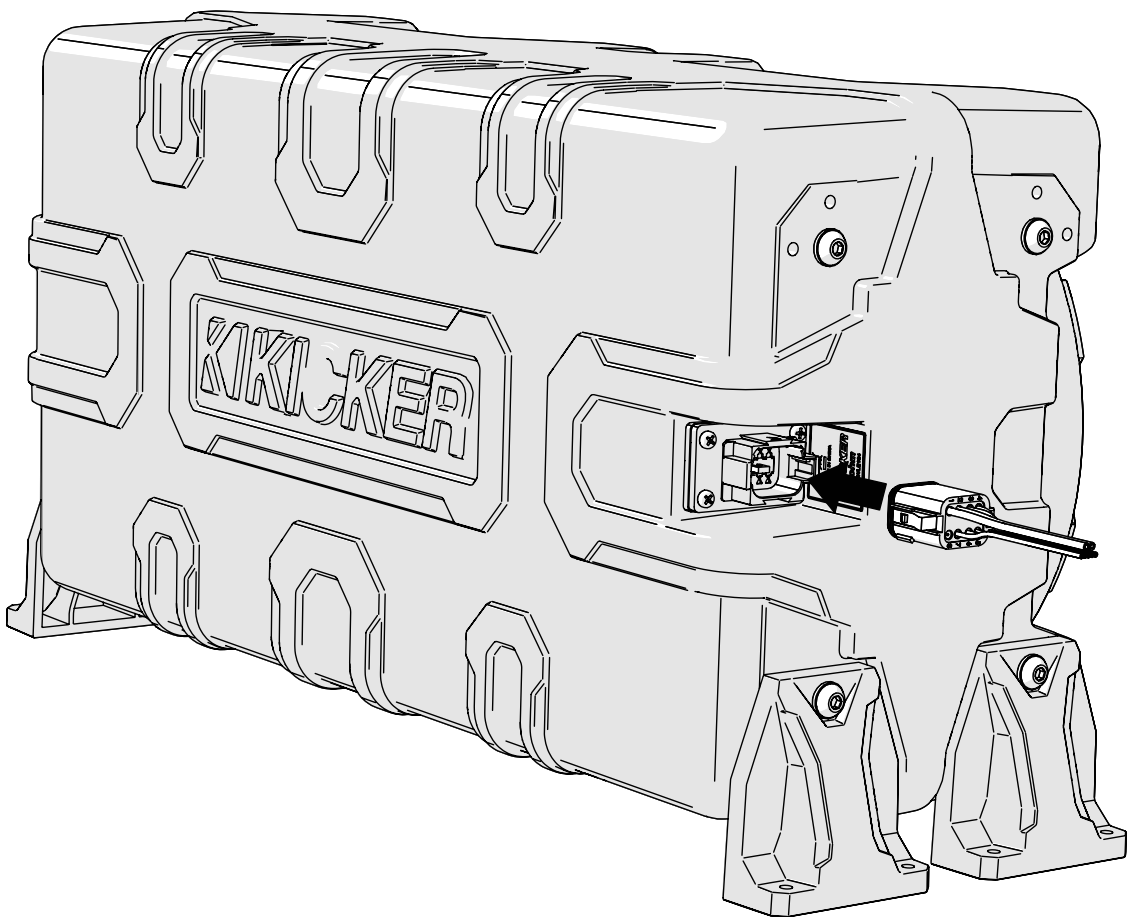

Pro Tip: You're a KICKER [KXM amplifier](#) and [a few cables](#) away from a full system upgrade that will dominate out on the water! Also, ask your [KICKER Dealer](#) about KICKER Premium Marine speaker & amplifier upgrades!

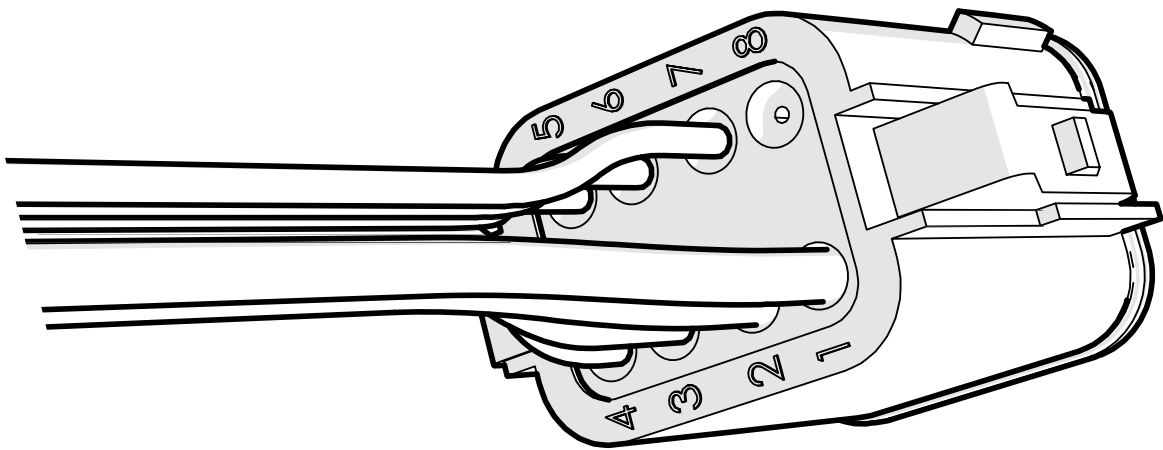

1. Speaker +

2. Speaker -

3. White LED (negative)

4. Blue LED (negative)

5. Red LED (negative)

6. Green LED (negative)

7. Black LED (positive)

2. Connect the positive and negative wires to your amplifier:

3. Connect the LED wires to your battery. Splice and combine the negative wires to yield a different color. See the following page for more detail.

When wiring the LED lighting, the black lead is +12V and the blue, red, green and white leads are ground.

1. Connect the black LED wire to the positive terminal of the battery.

a. Place a 2-amp fuse (not included) no further than 7" away from the battery terminal.

b. Install a switch (not included) on the black LED wire between the fuse and the speaker, so the LED's can be turned off. Without a switch to turn them off, they will always be on.

2. Connect the red, blue, green, and/or white LED wires to the negative terminal of the battery. See the chart below for available combinations.

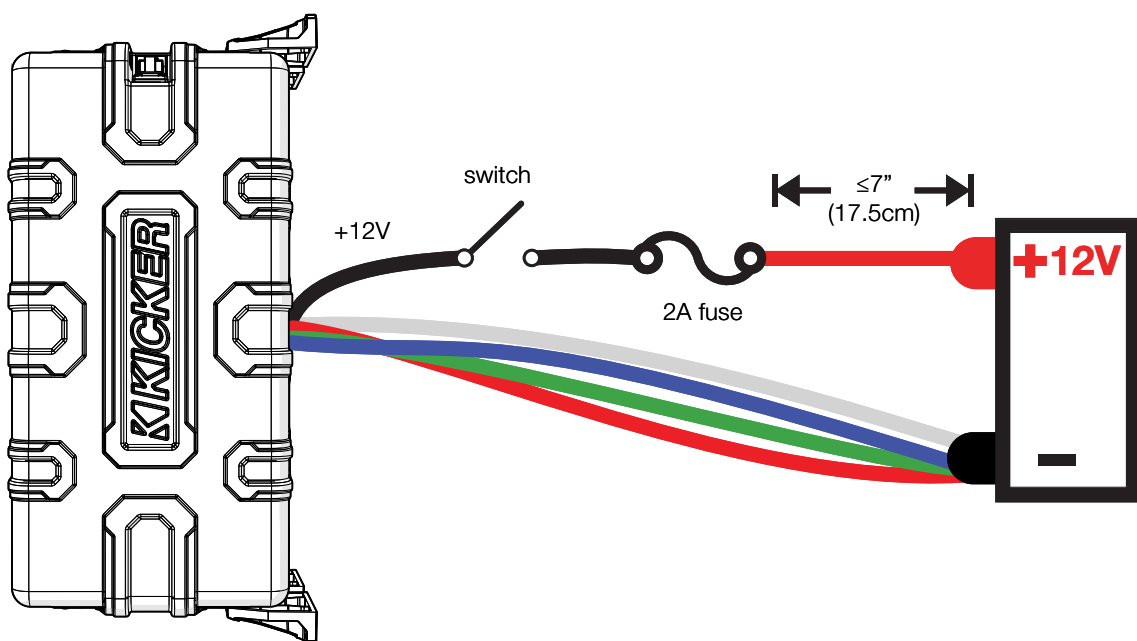

Color Combinations: Splice and combine the ground wires to yield a different color.

Wires Connected to Negative Terminal	LED Color
Red	Red
Green	Green
Blue	Blue
White	White
Red/Green	Lime Green
Red/Blue	Magenta
Blue/Green	Aquamarine
Red/Green/Blue	Blue-White

Mounting

To avoid potential injury or possible death from forward movement of the enclosure during abrupt stops or accidents, the enclosure must be properly installed and securely fastened. You are solely responsible for securely fastening the enclosure. Make sure the mounting screws will not puncture the gas tank, wiring or interfere with any mechanical parts on the underside of the mounting surface.

Mount the brackets to the enclosure using one of three configurations:

Forward-Firing

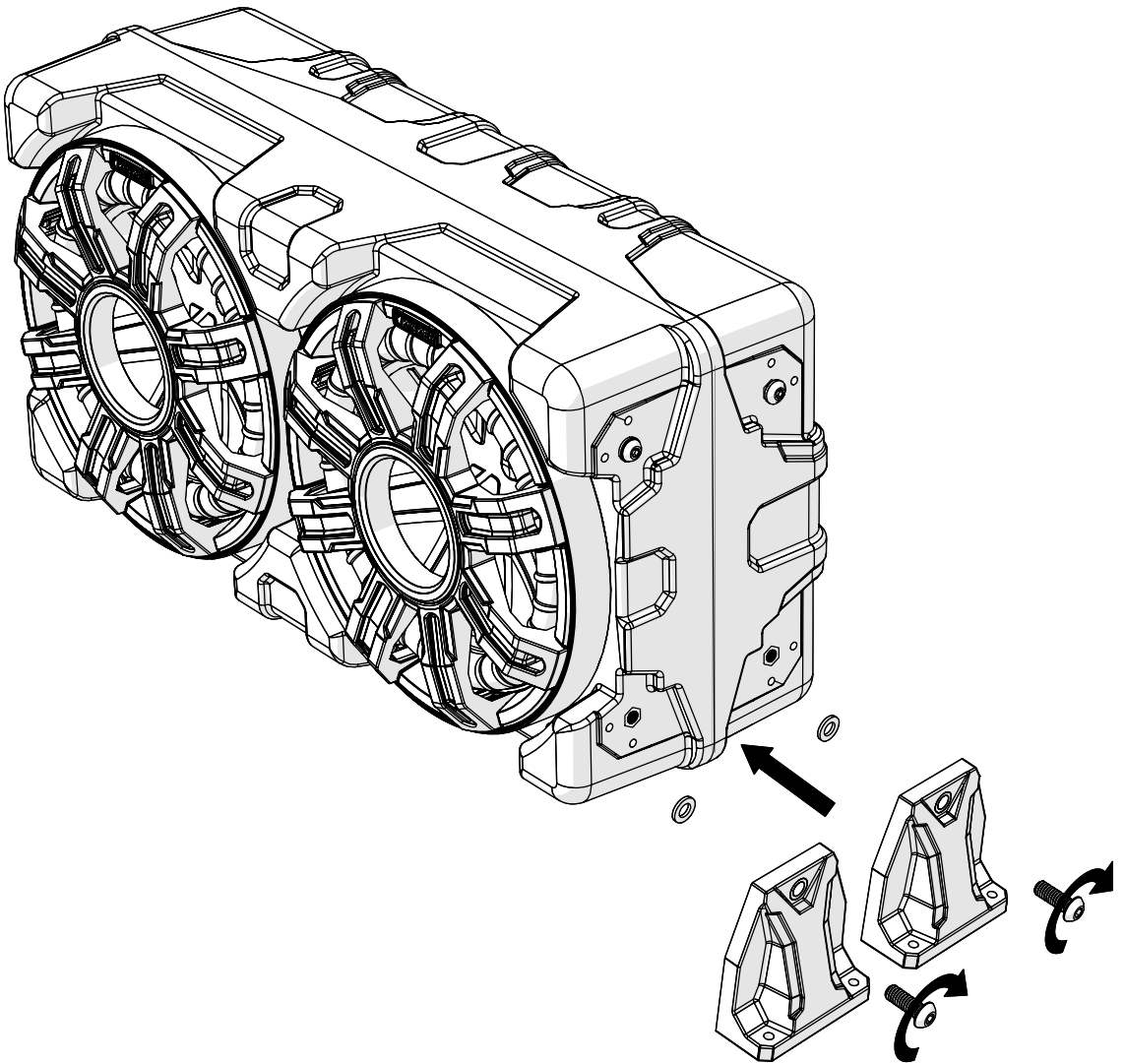

Up-Firing

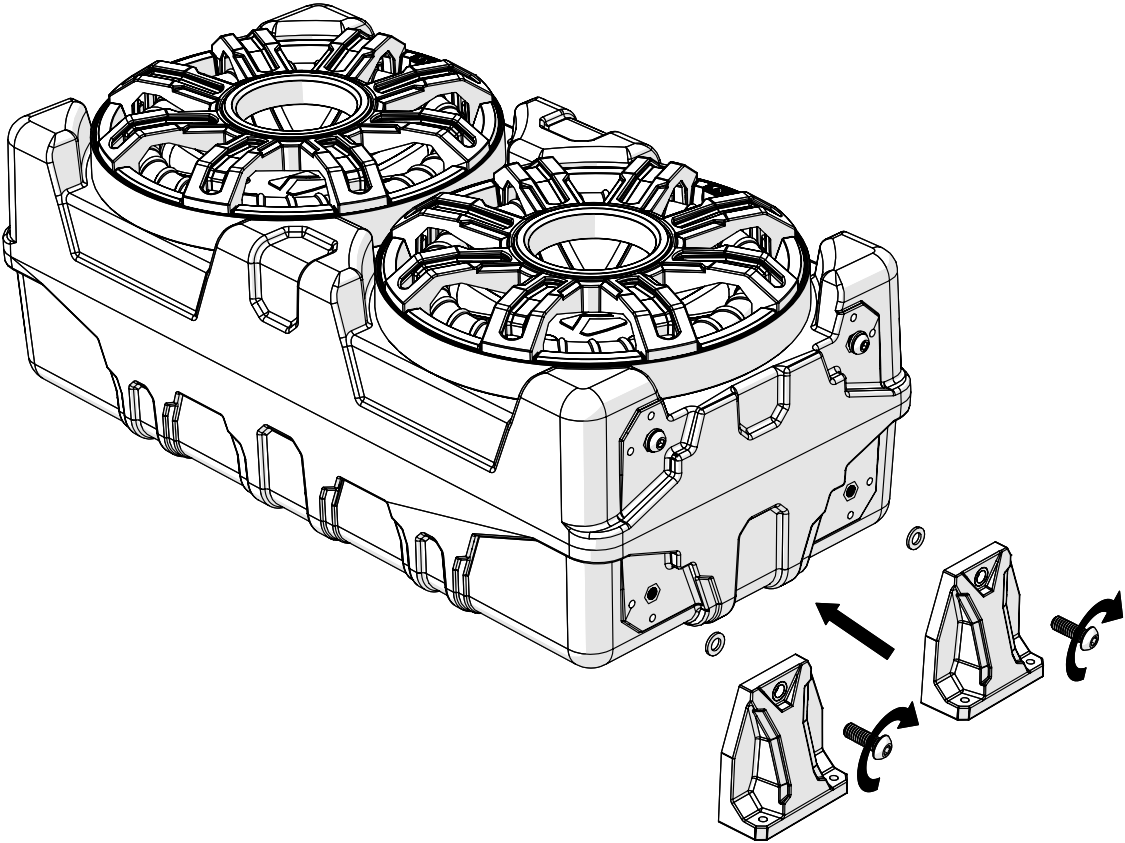

Down-Firing

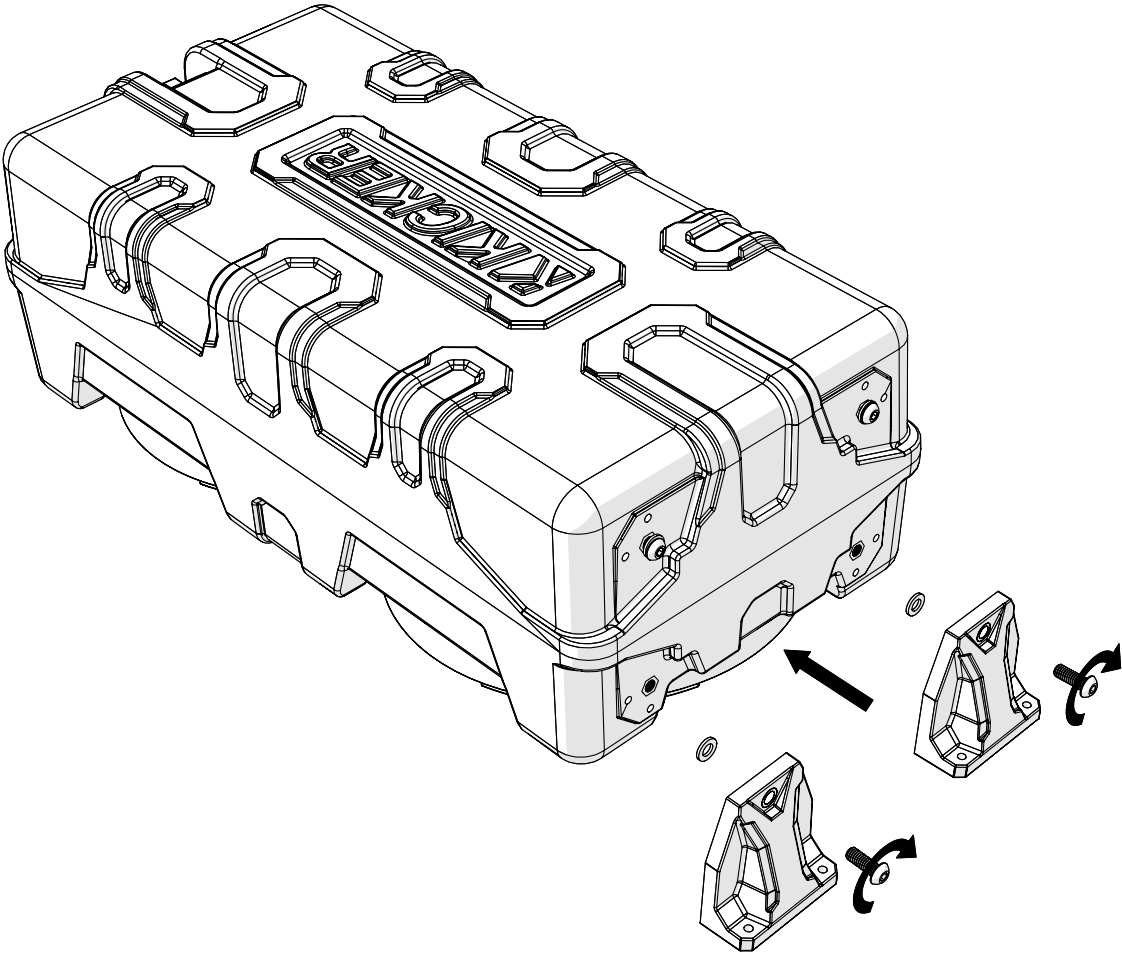

Warranty

When purchased from an Authorized KICKER Dealer, KICKER warrants this product to be free from defects in material and workmanship under normal use for a period of TWO (2) YEARS from date of original purchase with receipt. If this product is identified as “Refurbished” or “B Goods”, the warranty is limited to a period of THREE (3) MONTHS from the date of original purchase. In all cases you must have the original receipt. Should service be necessary under this warranty for any reason due to manufacturing defect or malfunction during the warranty period, KICKER will repair or replace (at its discretion) the defective merchandise with equivalent merchandise. Warranty replacements may have cosmetic scratches and blemishes. Discontinued products may be replaced with more current equivalent products. This warranty is valid only for the original purchaser and is not extended to owners of the product subsequent to the original purchaser. Any applicable implied warranties are limited in duration to a period of the express warranty as provided herein beginning with the date of the original purchase at retail, and no warranties, whether express or implied, shall apply to this product thereafter. Some states do not allow limitations on implied warranties; therefore, these exclusions may not apply to you. This warranty gives you specific legal rights; however you may have other rights that vary from state to state.

WHAT TO DO IF YOU NEED WARRANTY OR SERVICE:

Defective merchandise should be returned to your local Authorized Stillwater Designs (KICKER) Dealer for warranty service. Assistance in locating an Authorized Dealer can be found at www.KICKER.com or by contacting Stillwater Designs directly. You can confirm that a dealer is authorized by asking to see a current authorized dealer window decal.

If it becomes necessary for you to return defective merchandise directly to Stillwater Designs (KICKER), call the KICKER Customer Service Department at (405) 624-8510 for a Return Merchandise Authorization (RMA) number. Package only the defective items in a package that will prevent shipping damage, and return to:

Stillwater Designs
3100 North Husband St
Stillwater, OK 74075

The RMA number must be clearly marked on the outside of the package. Please return only defective components. The return of functioning items increases your return freight charges. Non-defective items will be returned freight collect to you. For example, if a subwoofer is defective, only return the defective subwoofer, not the entire enclosure. Include a copy of the original receipt with the purchase date clearly visible, and a “proof-of-purchase” statement listing the Customer’s name, Dealer’s name and invoice number, and product purchased. Warranty expiration on items without proof-of-purchase will be determined from the type of sale and manufacturing date code. Freight must be prepaid; items sent freight-collect, or COD, will be refused.

WHAT IS NOT COVERED?

This warranty is valid only if the product is used for the purpose for which it was designed. It does not cover:

- o Damage due to improper installation
- o Subsequent damage to other components
- o Damage caused by exposure to moisture, excessive heat, chemical cleaners, and/or UV radiation
- o Damage through negligence, misuse, accident or abuse. Repeated returns for the same damage may be considered abuse
- o Any cost or expense related to the removal or reinstallation of product
- o Speakers damaged due to amplifier clipping or distortion
- o Items previously repaired or modified by any unauthorized repair facility
- o Return shipping on non-defective items
- o Products with tampered or missing barcode labels
- o Products with tampered or missing serial numbers
- o Products returned without a Return Merchandise Authorization (RMA) number
- o Products purchased from an UNAUTHORIZED dealer
- o Freight Damage
- o The cost of shipping product to KICKER
- o Service performed by anyone other than KICKER

HOW LONG WILL IT TAKE?

KICKER strives to maintain a goal of one-week service for all acoustics (subwoofers, midrange drivers, tweeters, crossovers, etc) returns. Delays may be incurred if lack of replacement inventory or parts is encountered. Failure to follow these steps may void your warranty. Any questions can be directed to the KICKER Customer Service Department at (405) 624-8510. Contact your International KICKER dealer or distributor concerning specific procedures for your country’s warranty policies.

Garantía | Garantie

Contact your International KICKER dealer or distributor concerning specific procedures for your country's warranty policies.

Our goods come with guarantees that cannot be excluded under the **Australian Consumer Law**. You are entitled to a replacement or refund for a major failure and for compensation for any other reasonably foreseeable loss or damage. You are also entitled to have the goods repaired or replaced if the goods fail to be of acceptable quality and the failure does not amount to a major failure.

GARANTÍA INTERNACIONAL **Versión Español**

Comuníquese con su concesionario o distribuidor KICKER internacional para obtener información sobre procedimientos específicos relacionados con las normas de garantía de su país.

La frase “combustible para vivir la vida Livin' Loud™ a todo volumen” se refiere al entusiasmo por la vida que la marca KICKER de estéreos de automóvil representa y a la recomendación a nuestros clientes de que vivan lo mejor posible (“a todo volumen”) en todo sentido. La línea de altavoces y amplificadores KICKER es la mejor del mercado de audio de automóviles y por lo tanto representa el “combustible” para vivir a todo volumen en el área de “estéreos de automóvil” de la vida de nuestros clientes. Recomendamos a todos nuestros clientes que obedezcan todas las reglas y reglamentos locales sobre ruido en cuanto a los niveles legales y apropiados de audición fuera del vehículo.

INTERNATIONALE GARANTIE **Deutsche Version**

Nehmen Sie mit Ihren internationalen KICKER-Fachhändler oder Vertrieb Kontakt auf, um Details über die Garantieleistungen in Ihrem Land zu erfahren.

Der Slogan “Treibstoff für Livin' Loud” bezieht sich auf die mit den KICKER-Autostereosystemen assoziierte Lebensfreude und die Tatsache, dass wir unsere Kunden ermutigen, in allen Aspekten ihres Lebens nach dem Besten (“Livin' Loud”) zu streben. Die Lautsprecher und Verstärker von KICKER sind auf dem Markt für Auto-Soundsysteme führend und stellen somit den “Treibstoff” für das Autostereoerlebnis unserer Kunden dar. Wir empfehlen allen unseren Kunden, sich bezüglich der zugelassenen und passenden Lautstärkepegel außerhalb des Autos an die örtlichen Lärmvorschriften zu halten.

GARANTIE INTERNATIONALE **Versión Française**

Pour connaître les procédures propres à la politique de garantie de votre pays, contactez votre revendeur ou distributeur International KICKER.

L'expression “ carburant pour vivre plein pot “ fait référence au dynamisme de la marque KICKER d'équipements audio pour véhicules et a pour but d'encourager nos clients à faire le maximum (“ vivre plein pot “) dans tous les aspects de leur vie. Les haut-parleurs et amplificateurs KICKER sont les meilleurs dans le domaine des équipements audio et représentent donc pour nos clients le “ carburant pour vivre plein pot “ dans l'aspect “ installation audio de véhicule “ de leur vie. Nous encourageons tous nos clients à respecter toutes les lois et réglementations locales relatives aux niveaux sonores acceptables à l'extérieur des véhicules.

P.O. Box 459

Stillwater, Oklahoma 74076

USA

(405) 624-8510

 **stillwaterdesigns**

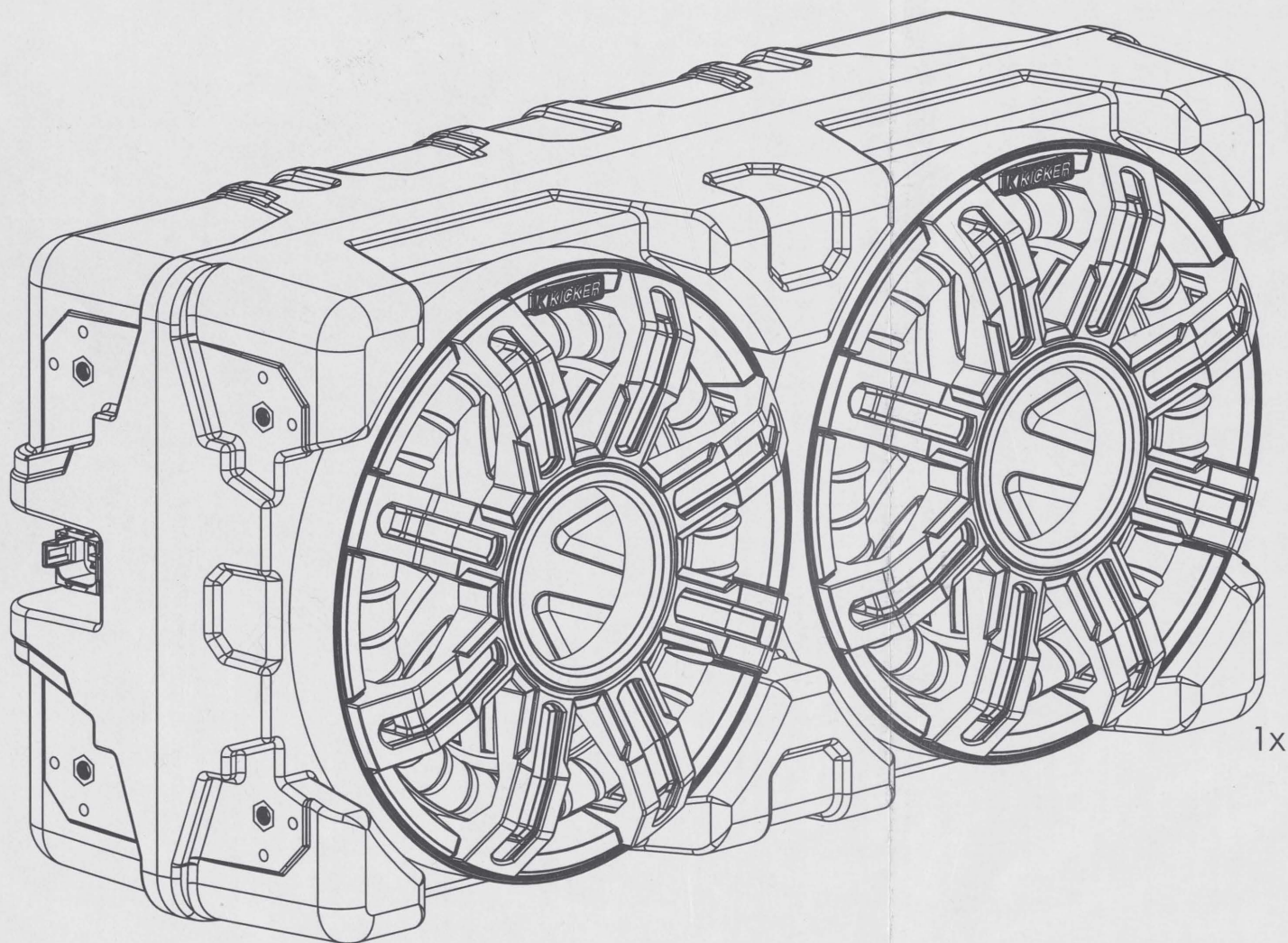

1x

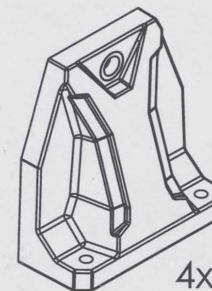

4x



8x



8x



4x



4x



8x

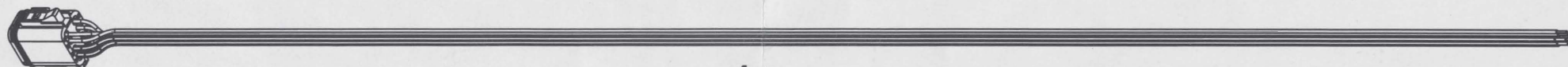

1x