



INSTALLATION INSTRUCTIONS FOR PART 99-9223

APPLICATIONS

Volvo S60/V70 2001-2004 99-9223



KIT FEATURES

- DIN head unit provision with pocket

KIT COMPONENTS

- A) Radio housing

A

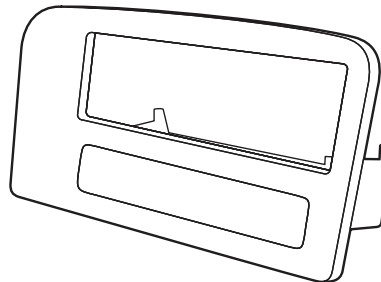

WIRING & ANTENNA CONNECTIONS (sold separately)

Wiring Harness:

- 70-9221 - Harness for select Volvo vehicles 1999-2003

Antenna Adapter:

- 40-VL10 - Adapter cable for select Volvo 1999-up

TOOLS REQUIRED

- Phillips screwdriver • T-25 Torx driver

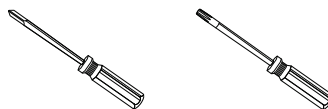

REV. 5/1/12

METRA. THE WORLD'S BEST KITS.™



1-800-221-0932



metraonline.com

© COPYRIGHT 2004-2011 METRA ELECTRONICS CORPORATION



99-9223

Table of Contents

Dash Disassembly

– Volvo S60 2001-2004.....	3
– Volvo V70 2001-2004	3

Kit Assembly

– DIN head unit provision with pocket.....	4-5
--	-----

CAUTION: Metra recommends disconnecting the negative battery terminal before beginning any installation. All accessories, switches, and especially air bag indicator lights must be plugged in before reconnecting the battery or cycling the ignition.

Note: Refer to the instructions included with the aftermarket radio.



KNOWLEDGE IS POWER

Enhance your installation and fabrication skills by enrolling in the most recognized and respected mobile electronics school in our industry. Log onto www.installerinstitute.com or call 800-354-6782 for more information and take steps toward a better tomorrow.



Metra recommends MECP certified technicians

Volvo S60/V70 2001-2004

1. Unsnap gearshift trim bezel and slide back. (Figure A)
2. Remove (2) T-25 Torx from climate control assembly, angle the climate control panel out, insert fingers between the console and climate panel and pull down at the same angle. Remove the panel (some force may be required). (Figure B)
3. Remove (2) T-25 Torx from radio bottom in climate control cavity to remove radio. (Figure C)

Continue to kit assembly

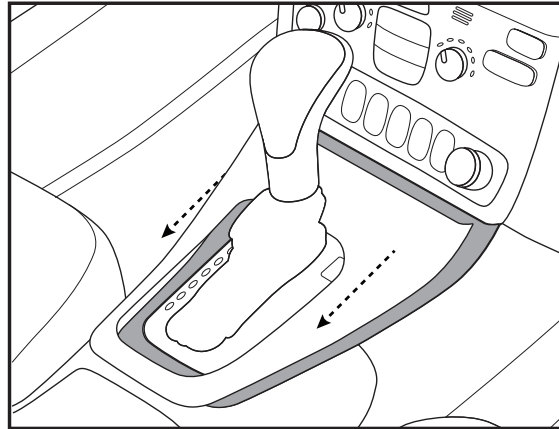

(Figure A)

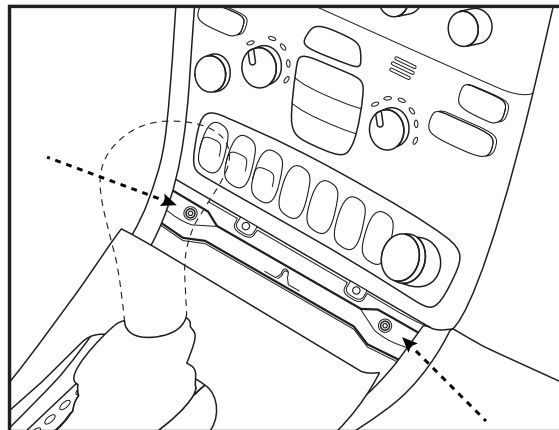

(Figure B)

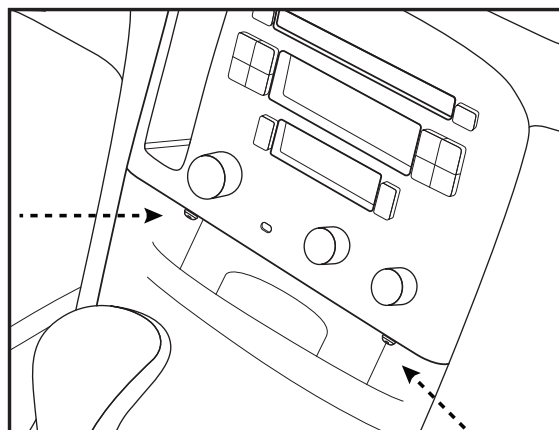

(Figure C)



Kit Assembly 99-9223

DIN head unit provision with pocket

1. With a Phillips screwdriver remove the kit rear support bracket. (Figure A)
2. After removing radio, with a T-25 Torx driver, remove (5) screws from radio bracket. (Figure B)
3. Depress snaps on top and bottom of pocket to remove from bracket. (Figure C)
4. Slide radio bracket off of radio.

Continue on next page

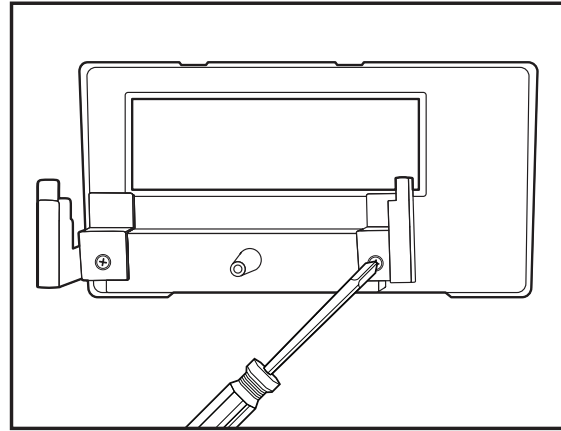

(Figure A)

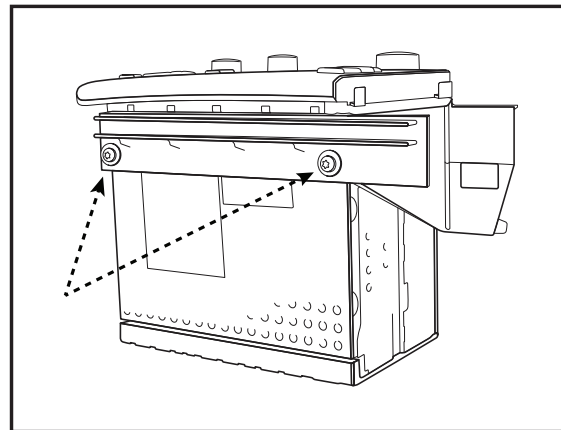

(Figure B)

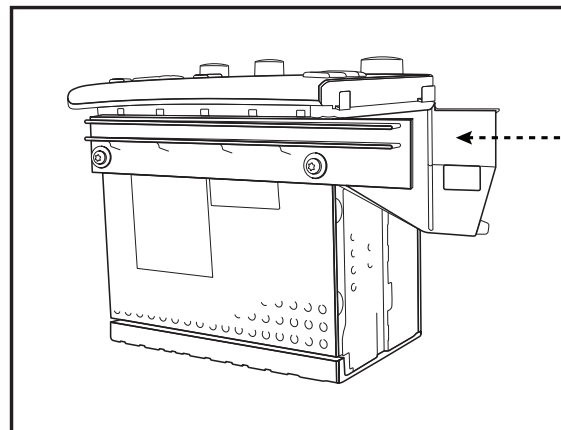

(Figure C)



Kit Assembly 99-9223

DIN head unit provision with pocket

5. Snap the radio housing into radio bracket and replace rear support brackets previously removed. (Figure D)
6. Slide the DIN cage into the radio opening, secure by bending the metal locking tabs down. (Figure E)
7. Slide the DIN unit (radio) into the cage until its secure. (Figure F)
8. Locate the factory wiring harness in the dash. Metra recommends using the proper mating adapter from Metra or AXXESS. Re-connect the negative battery terminal and test the unit for proper operation.
9. Reassemble dash in reverse order of disassembly.

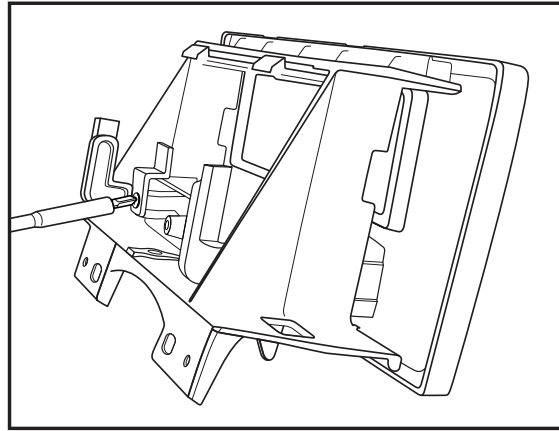

(Figure D)

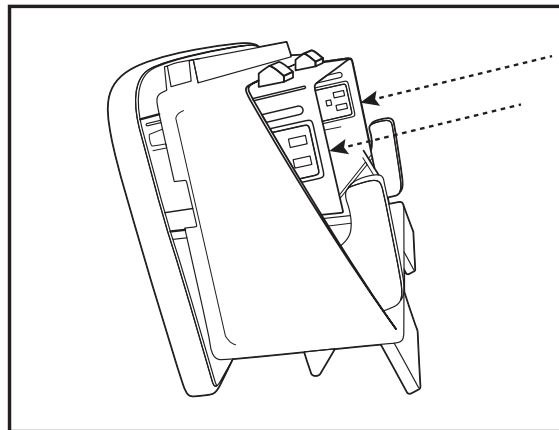

(Figure E)

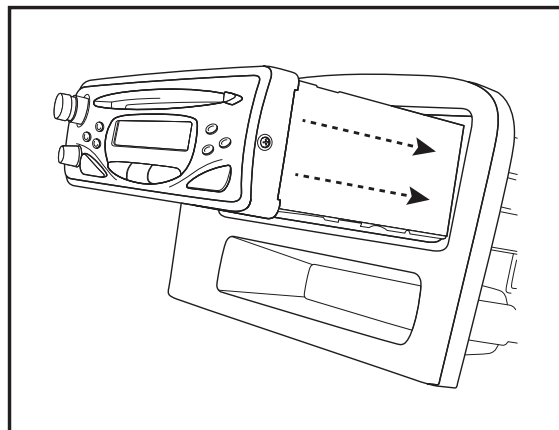

(Figure F)



INSTALLATION INSTRUCTIONS FOR PART 99-9223

REV. 5/1/12

METRA. THE WORLD'S BEST KITS.™



1-800-221-0932



metraonline.com

© COPYRIGHT 2004-2011 METRA ELECTRONICS CORPORATION