



## INSTALLATION INSTRUCTIONS FOR PART 99-9224

### APPLICATIONS 1999-2006 Volvo S80

# 99-9224

#### KIT FEATURES

- DIN Head Unit Provision with Pocket

#### KIT COMPONENTS

(A) Radio Housing

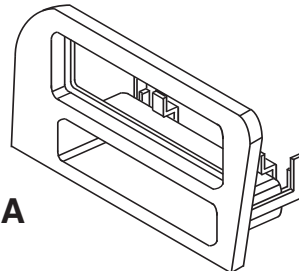

A

#### TOOLS REQUIRED:

Phillips Screwdriver • T-25 Torx Driver

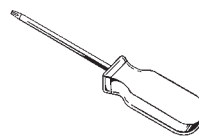
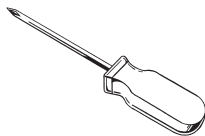

1-800-221-0932



[www.metraonline.com](http://www.metraonline.com)

© COPYRIGHT 2004 METRA ELECTRONICS CORPORATION



# **TABLE OF CONTENTS**

---

***Dash Disassembly***  
***1999-2006 Volvo S80* .....1,2**

***Kit Assembly***  
***DIN Head Unit Provision with Pocket* ..... 3**

***Final Assembly* ..... 4**

## 1999-2006 VOLVO S80

- 1** Disconnect the negative battery terminal to prevent an accidental short circuit.
- 2** Unsnap gear shifter trim panel. (Figure A)
- 3** Unsnap gear shifter boot to separate it from the gear shifter trim panel and remove trim panel. (Figure B)
- 4** Remove (2) T-25 Torx head screws from bottom of climate controls. (Figure C)
- 5** Unsnap the climate controls from bottom edge of the radio. Unplug and remove the climate controls. (Figure D)

**A**

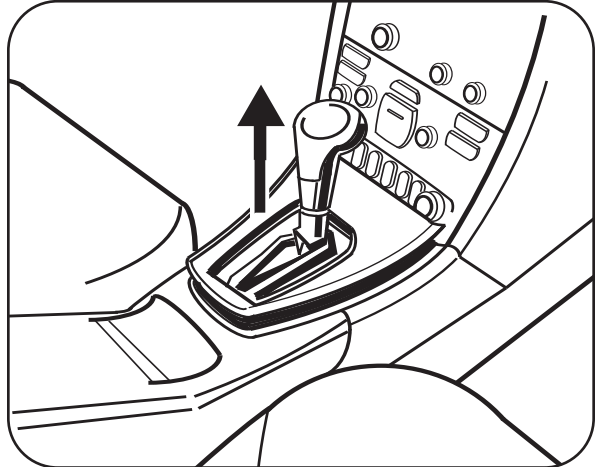

**B**

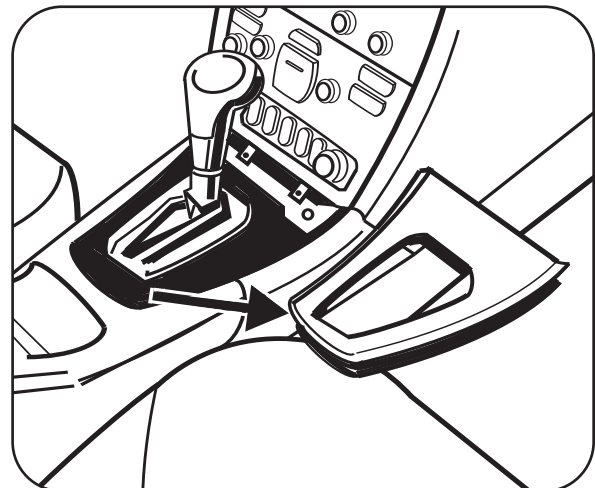

**C**

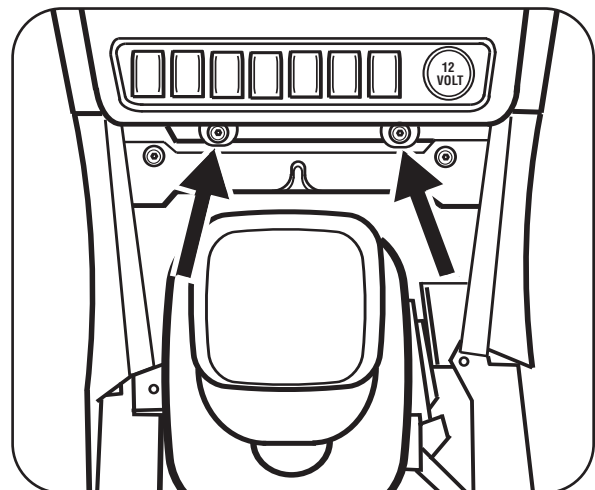

**D**

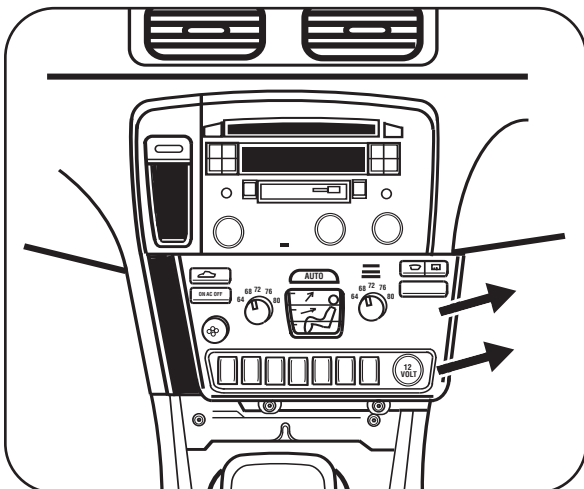

## 1999-2006 VOLVO 580

- 6 Remove (2) T-25 Torx head screws from bottom of radio. Unplug and remove the radio. (Figure E)
- 7 Depress the snaps on the top and bottom of the pocket to remove it from the radio bracket. (Figure F)
- 8 Remove (5) T-25 Torx head screws securing the radio to the radio bracket and slide the bracket off of the radio. (See Figure G)  
**Note: Save the radio bracket for use with radio housing.** (Figure H)

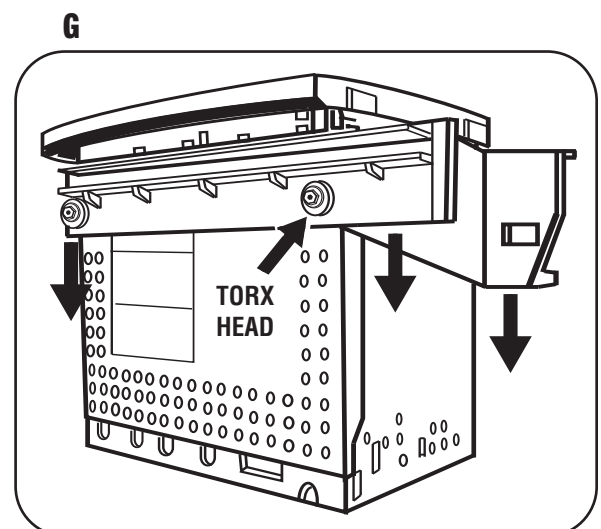
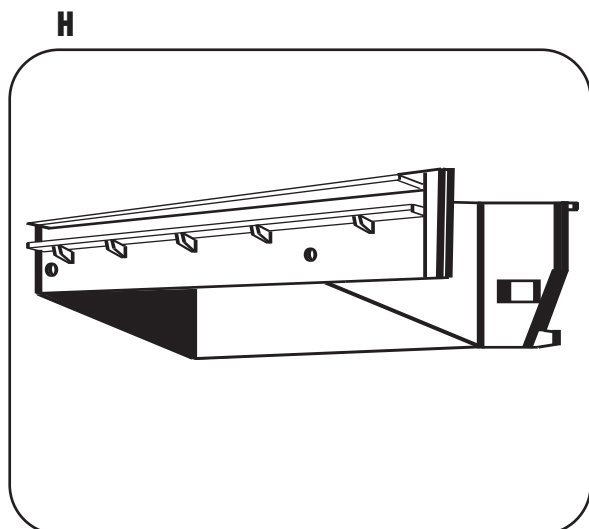
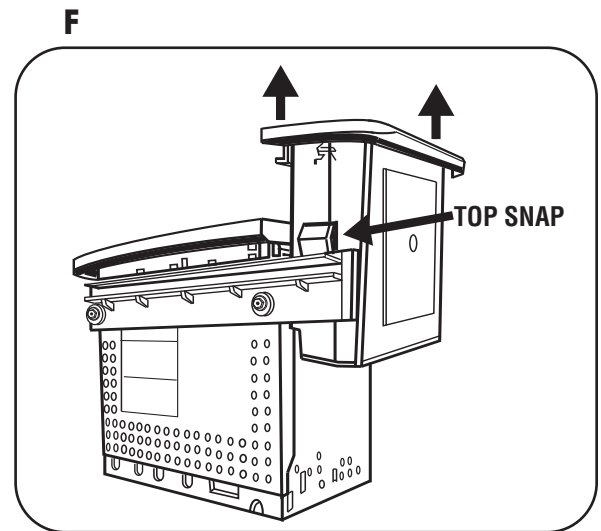
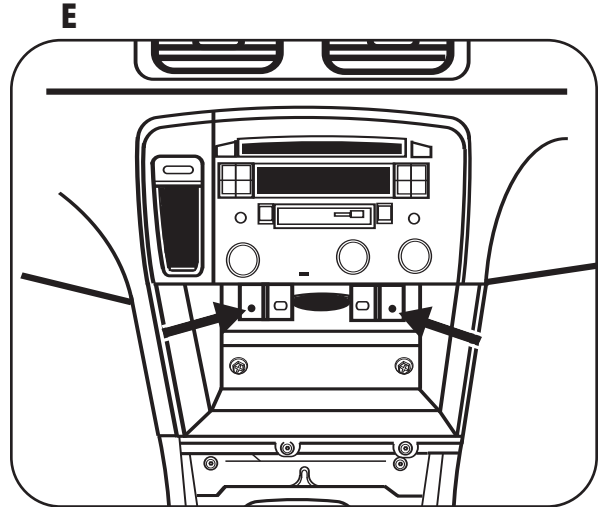

## DIN HEAD UNIT PROVISION

**NOTE:** Also refer to the instructions included with the aftermarket radio.

- 1** Using a Phillips screw driver remove the rear support bracket from the radio housing. (Figure A)
- 2** Snap the radio housing into the radio bracket (removed from factory radio) and replace rear support bracket. (Figure B)
- 3** Slide the DIN cage into the radio housing and secure by bending the metal locking tabs outward. (Figure C)
- 4** Slide the radio into the cage/ radio housing assembly until it snaps into place. (Figure D)

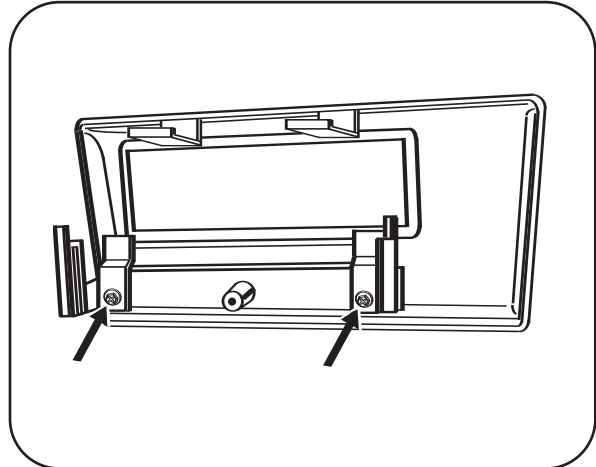
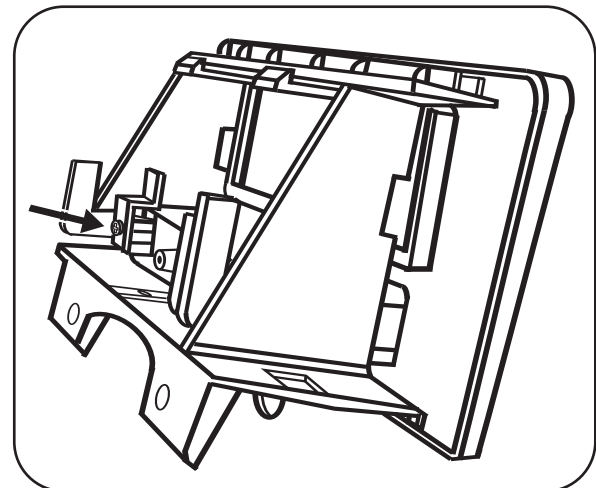
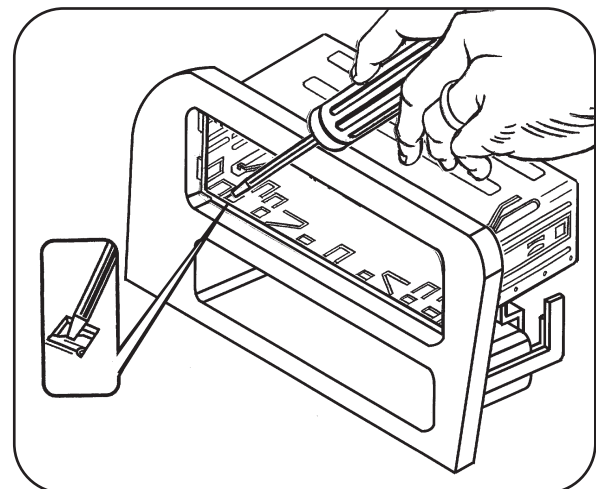
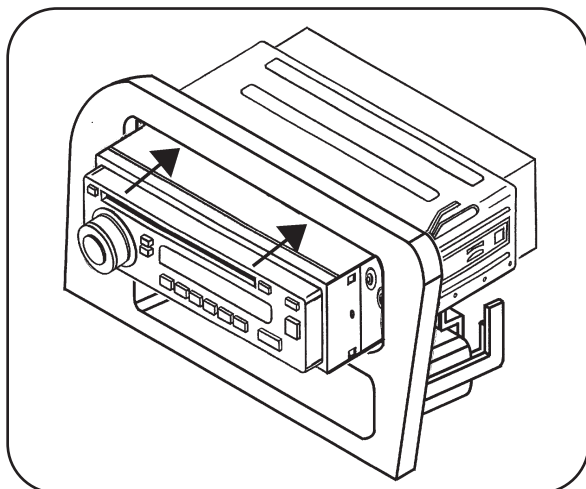
**A**

**B**

**C**

**D**

## FINAL ASSEMBLY

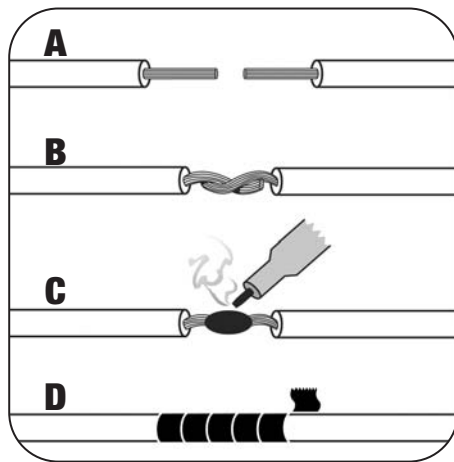
- 1** Locate the factory wiring harness in the dash and make the connection as shown. Metra recommends using the proper mating adapter and making the connections as shown. (Isolate and individually tape off the ends of any unused wires to prevent electrical short circuit.)
- 2** Re-connect the negative battery terminal and test the unit for proper operation.
- 3** Reassemble radio and dash assemblies in reverse order of disassembly.

### FINAL WIRING CONNECTIONS

Make wiring connections using the EIA color code chart shown below and the instructions included with the head unit. Metra recommends making connections as shown below; Strip, Splice, Solder, Tape. Isolate and individually tape off ends of any unused wires to prevent electrical short circuit.



- A) Strip wire ends back 1/2"**
- B) Twist ends together**
- C) Solder**
- D) Tape**

### METRA / EIA WIRING CODE

12V Ignition / Acc . . . Red	Right Front (+) . . . . . Gray
12V Batt / Memory . . Yellow	Right Front (-) . . . . . Gray / Black
Ground . . . . . Black*	Left Front (+) . . . . . White
Power Antenna . . . . . Blue	Left Front (-) . . . . . White / Black
Amp Turn-On . . . . . Blue / White	Right Rear (+) . . . . . Violet
Amp Ground . . . . . Black / White	Right Rear (-) . . . . . Violet / Black
Illumination . . . . . Orange	Left Rear (+) . . . . . Green
Dimmer . . . . . Orange / White	Left Rear (-) . . . . . Green / Black

**\*NOTE:** When Black a wire is not present, ground radio to vehicle chassis.

All colors may not be present on all leads due to manufacturer's specifications.



# INST999224



**1-800-221-0932**



**[www.metraonline.com](http://www.metraonline.com)**

REV. 03/15/06

© COPYRIGHT 2004 METRA ELECTRONICS CORPORATION

INST99-9224