



INSTALLATION INSTRUCTIONS FOR PART 99-9302

APPLICATIONS

BMW Mini Cooper/Cooper S 2002-2007

99-9302

KIT FEATURES

- Mounting bracket



KIT COMPONENTS

- A) Mounting Bracket

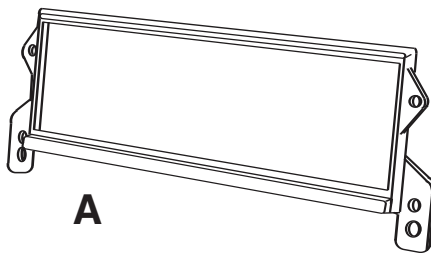

TOOLS REQUIRED:

- Small Flat Blade Screwdriver/ Panel Removal Tool
- Phillips Screwdriver • T-33 Torx Driver



1-800-221-0932



www.metraonline.com

© COPYRIGHT 2004-07 METRA ELECTRONICS CORPORATION



TABLE OF CONTENTS

Dash Disassembly

- BMW Mini Cooper/Cooper S 2002-2007 1,2

Kit Assembly

- DIN Mount Radio Provision 3

Final Assembly 4

***Note:**

Refer also to the instructions included with the aftermarket radio.

BMW Mini Cooper/Cooper S 2002-2007

- 1** Disconnect the negative battery terminal to prevent an accidental short circuit.
- 2** Carefully pry out both top edges of driver's knee panel and allow panel to hang. (Figure A)
- 3** Remove (2) Torx T-33 screws from driver's side rail trim. (Figure B)
- 4** Remove (2) Torx T-33 screws from passenger side rail trim. (On specially equipped models, it may be necessary to open the glove box to access these (2) screws) (Figure C)

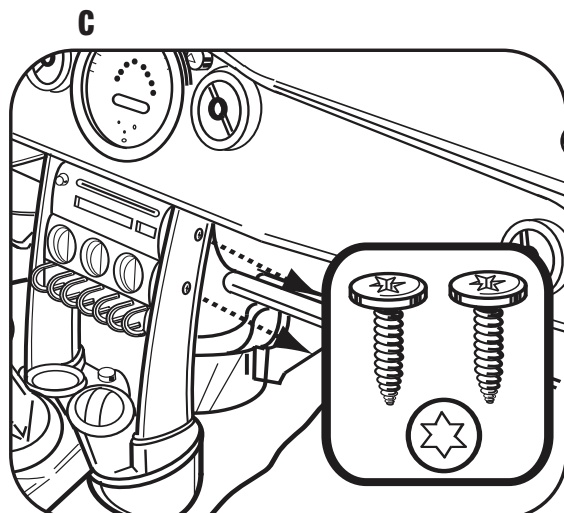
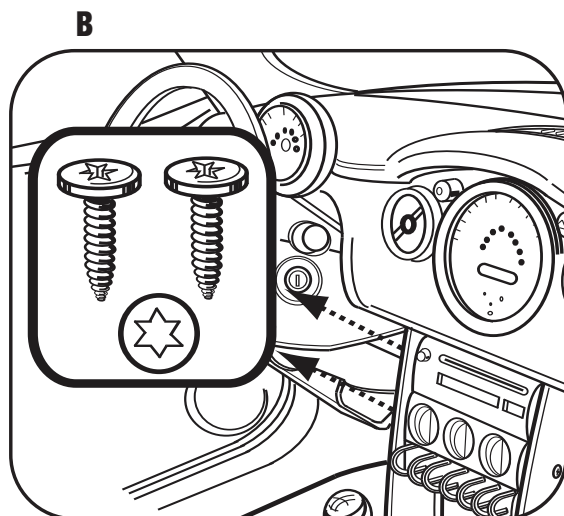
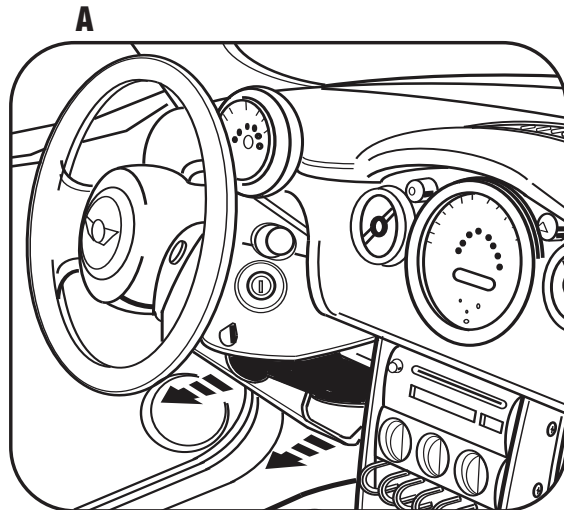

BMW Mini Cooper/Cooper S 2002-2007

5 Remove (1) Phillips scrow from each cup holder. (Figure D)

6 Carefully pry up mirror adjustment switch panel and remove (2) Phillips screws. (Figure E)

7 Slide cup holder/gear shift assembly toward rear of car and carefully remove side rail trims. (Figure F)

8 Remove (4) Phillip screws securing radio. Pull out radio, disconnect and remove. (Figure G)

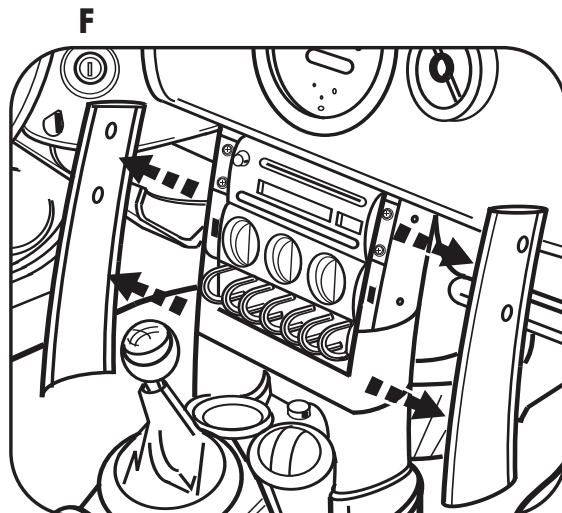
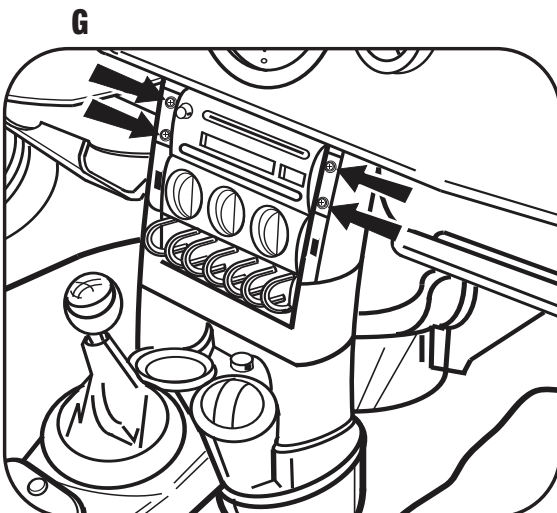
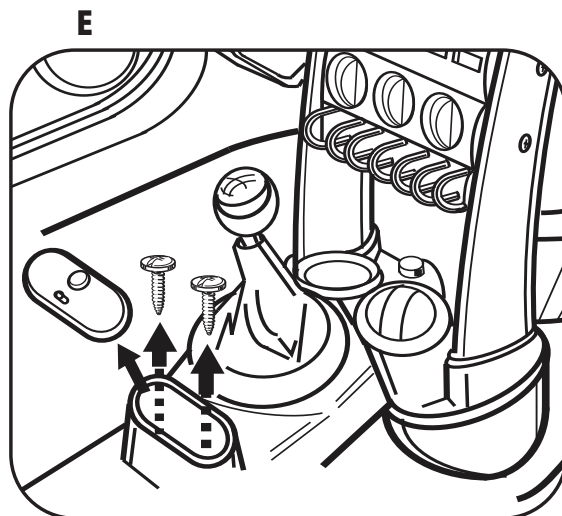
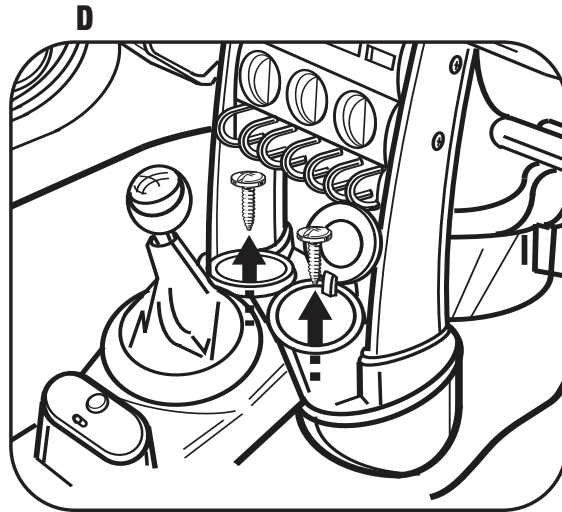

DIN MOUNT RADIO PROVISION

**Note: Refer also to the instructions included with the aftermarket radio.*

- 1** Slide the DIN cage into the radio opening of the Radio Housing and secure by bending the metal locking tabs outward. (Figure A)
- 2** Slide the aftermarket radio unit into the cage until it snaps into place. (Figure B)

Continue to final assembly.

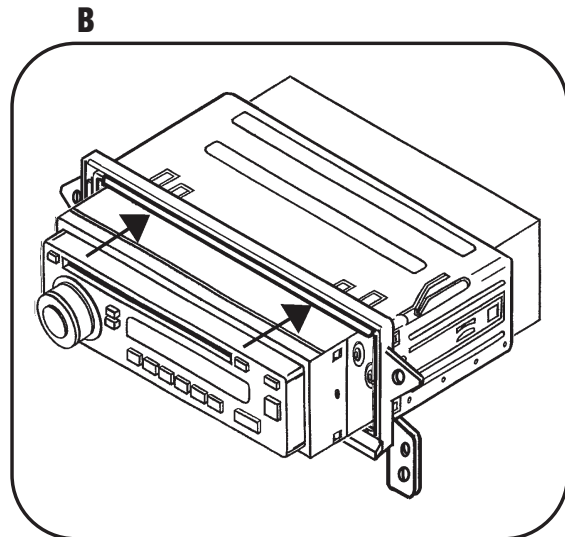
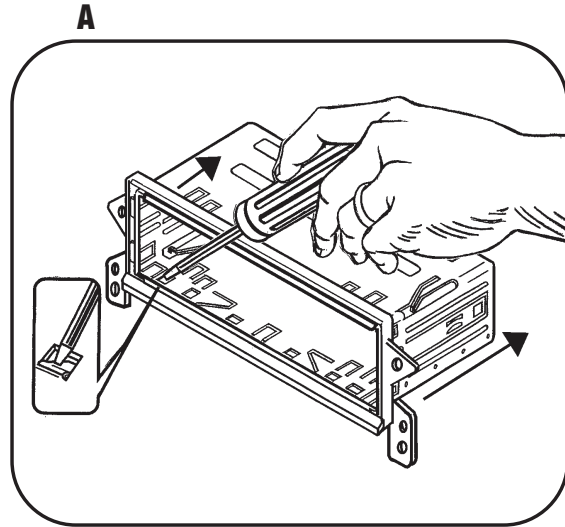

FINAL ASSEMBLY

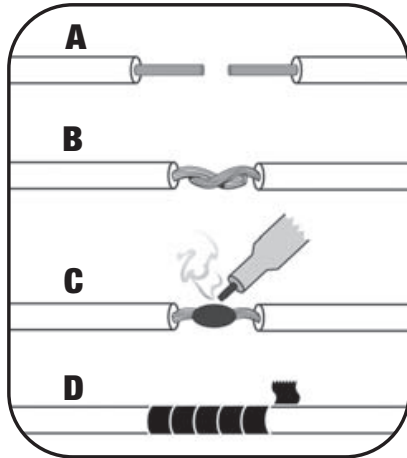

- (A) Strip wire ends back 1/2"***
- (B) Twist ends together***
- (C) Solder***
- (D) Tape***

- 1** Locate the factory wiring harness in the dash. Metra recommends using the proper mating adapter and making connections as shown. (Isolate and individually tape off the ends of any unused wires to prevent electrical short circuit.)
- 2** Re-connect the negative battery terminal and test the unit for proper operation.
- 3** Reassemble radio and dash assemblies in reverse order of disassembly.

FINAL WIRING CONNECTIONS

Make wiring connections using the EIA color code chart shown below and the instructions included with the head unit. Metra recommends making connections as shown below; Strip, Splice, Solder, Tape. Isolate and individually tape off ends of any unused wires to prevent electrical short circuit.

METRA / EIA WIRING CODE

12V Ignition / Acc. Red	Right Front (+) Gray
12V Batt / Memory Yellow	Right Front (-) Gray/ Black
Ground Black*	Left Front (+) White
Power Antenna Blue	Left Front (-) White / Black
Amp Turn-On Blue / White	Right Rear (+) Violet
Amp Ground Black / White	Right Rear (-) Violet / Black
Illumination Orange	Left Rear (+) Green
Dimmer Orange / White	Left Rear (-) Green / Black

***NOTE:** When a Black wire is not present, ground radio to vehicle chassis.
All colors may not be present on all leads due to manufacturer's specifications.

99-9302 INSTRUCTIONS



1-800-221-0932  **www.metraonline.com**

REV. 06/19/07 © COPYRIGHT 2004-07 METRA ELECTRONICS CORPORATION

INST99-9302