



120999306B



INSTALLATION INSTRUCTIONS FOR PART 99-9306B

APPLICATIONS
BMW 1-Series 2008-10
3-Series 2006-10
(Without Factory Navigation)

99-9306B

KIT FEATURES

- DIN Head Unit Provisions
- ISO DIN Head Unit Provision
- *Painted Matte Black to Match Factory Dash*

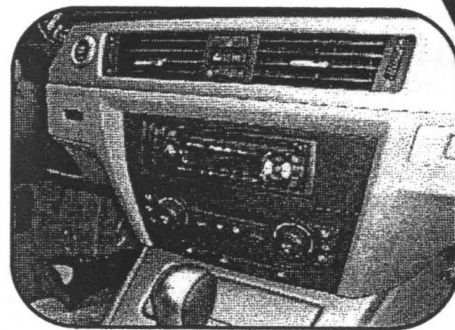

KIT COMPONENTS

- A) Radio Housing • B) ISO Brackets • C) ISO Trim Plate

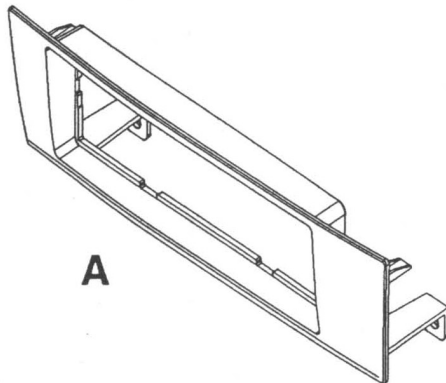

A

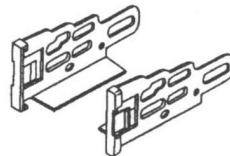

B

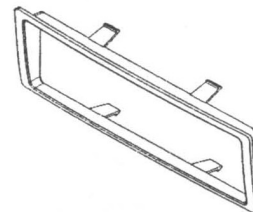

C

TOOLS REQUIRED:

- Phillips Screwdriver • Panel Removal Tool • Small Flat Blade Screwdriver

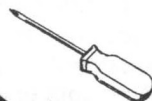

1-800-221-0932



www.metraonline.com

© COPYRIGHT 2004-2009 METRA ELECTRONICS CORPORATION

TABLE OF CONTENTS

Dash Disassembly

**- BMW 1-Series 2008-10, 3-Series 2006-10
(Without factory NAV)1**

Kit Assembly

- Kit Preparation

DIN Head Unit Provision 2

ISO DIN Head Unit Provision 3

Note:

Refer also to the instructions included with the aftermarket radio.



Metra recommends MECP certified technicians.



KNOWLEDGE IS POWER

Enhance your installation and fabrication skills by enrolling in the most recognized and respected mobile electronics school in our industry. Log onto www.installerinstitute.com or call 800-354-6782 for more information and take steps toward a better tomorrow.

BMW 1-Series 2008-10/3-Series 2006-10
(WITHOUT FACTORY NAV)

1 Disconnect the negative battery terminal to prevent an accidental short circuit.

2 Carefully unclip and remove climate controls. (Figure A)

3 Remove (2) Phillips screws exposed at bottom of radio and remove. (Figure B)

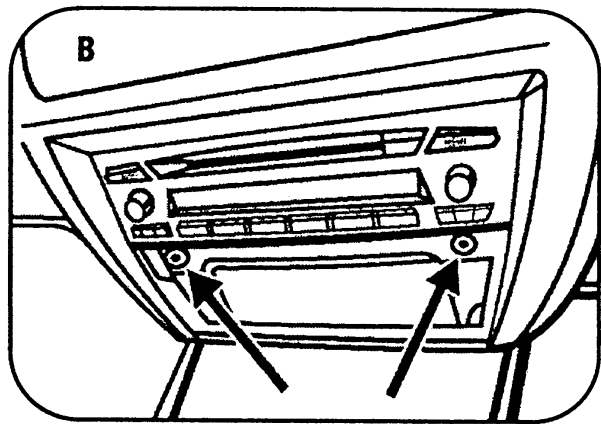
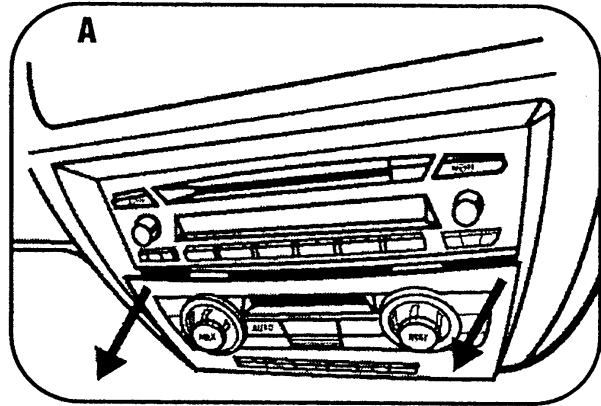

BMW 1-Series 2008-10/3-Series 2006-10
(WITHOUT FACTORY NAV)**DIN Head Unit Provision**

- 1 Screw the 99-9306B housing into the dash opening instead of the factory radio. (Figure A)
- 2 Slide the DIN cage into the space in the 99-9306B and secure by bending the metal locking tabs outward. (Figure B)
- 3 Slide the aftermarket head unit into the DIN cage until secure. (Figure C)
- 4 Re-connect the negative battery terminal and test the unit for proper operation.
- 5 Reassemble radio and dash assemblies in reverse order of disassembly.

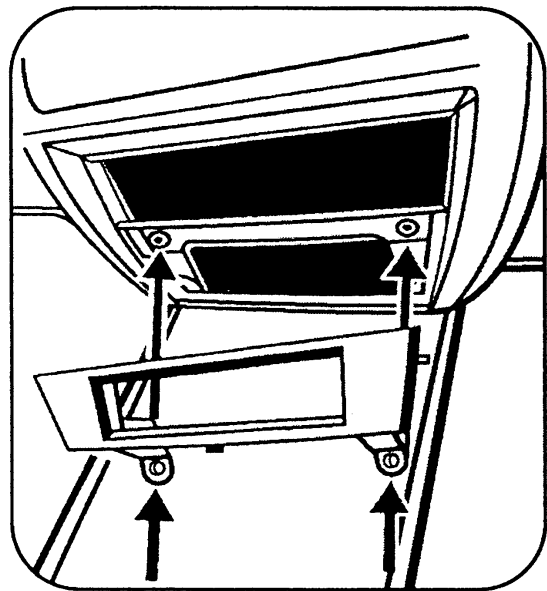
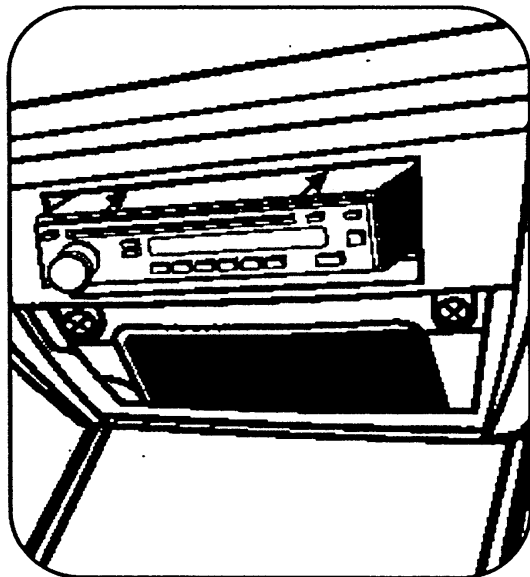
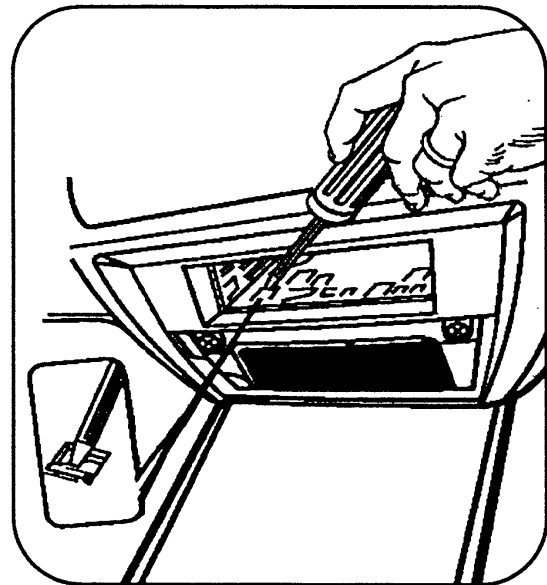
**A****C****B**

BMW 1-Series 2008-10/3-Series 2006-10
(WITHOUT FACTORY NAV)

ISO DIN Head Unit Provision

- 1 Locate the factory wiring harness in the dash. Metra recommends using the proper mating adapter from Metra or AXCESS. Re-connect the negative battery terminal and test the unit for proper operation.
- 2 Mount the ISO Brackets to the head unit with the screws supplied with the unit. (Figure A)
- 3 Slide the head unit into the radio opening until the side clips engage. (Figure B)
- 4 Snap the Trim plate into the Radio Housing. (Figure B)
- 5 Reassemble dash in reverse order of disassembly.

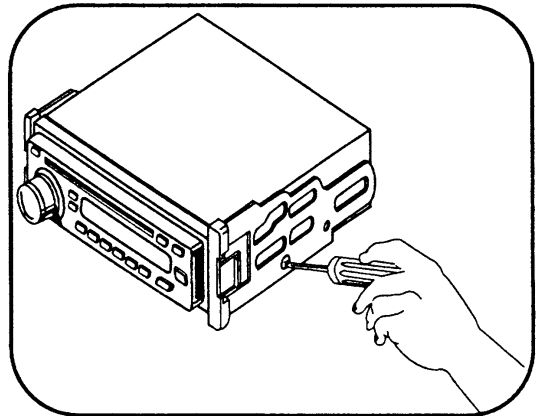

A

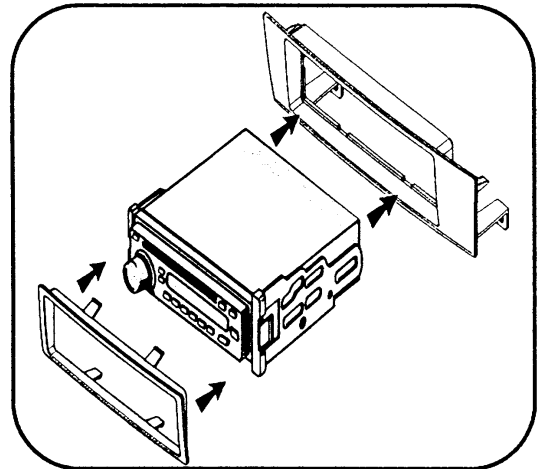

B

