



## INSTALLATION INSTRUCTIONS FOR PART 99-9309

### APPLICATIONS

**2007-2008 Mini Cooper**  
(All Excluding Convertible)

**2009-up Mini Cooper (All)**  
**2009-up Mini Cooper Clubman**

# 99-9309

### KIT FEATURES

- ISO DIN Head unit provision with pocket
- DDIN Head unit provision



### KIT COMPONENTS

- A) Radio Housing • B) ISO Brackets • C) DDIN Brackets • D) Storage Pocket
- E) Climate Control Button Covers • F) Speedometer Blank-Out Panel
- G) (8) #8 3/8" Phillips Screws

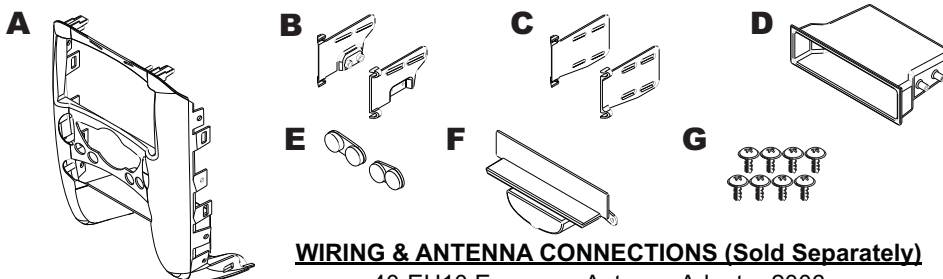

#### WIRING & ANTENNA CONNECTIONS (Sold Separately)

- 40-EU10 European Antenna Adapter 2006-up
- BMRC-01 BMW/Mini Interface

### TOOLS REQUIRED

- Phillips Screwdriver • Panel Removal Tool • Small Flat Blade Screwdriver
- Socket Wrench • T-20 Torx Drivers • T-30 Torx Drivers



**METRA. THE WORLD'S BEST KITS.™**



**1-800-221-0932**



**metraonline.com**

© COPYRIGHT 2004-2010 METRA ELECTRONICS CORPORATION



# INSTALLATION INSTRUCTIONS FOR PART 99-9309

## TABLE OF CONTENTS

### DASH DISASSEMBLY

- Mini Cooper . . . . . 1-5

### KIT PREPARATION

- Mini Cooper . . . . . 6

### KIT ASSEMBLY

#### Mini Cooper

- ISO DIN Head Unit Provision . . . . . 7
- DDIN / Stacked ISO DIN Head Unit Provision . . . . 8

**CAUTION:** Metra recommends disconnecting the negative battery terminal before beginning any installation. All accessories, switches, and especially air bag indicator lights must be plugged in before reconnecting the battery or cycling the ignition.

**\*NOTE:** Refer also to the instructions included with the aftermarket radio.



#### KNOWLEDGE IS POWER

Enhance your installation and fabrication skills by enrolling in the most recognized and respected mobile electronics school in our industry. Log onto [www.installerinstitute.com](http://www.installerinstitute.com) or call 800-354-6782 for more information and take steps toward a better tomorrow.



Metra recommends MECP certified technicians



## 99-9309 DASH DISASSEMBLY

### MINI COOPER

- 1** Open the upper glove box and remove the (2) screw covers from the left and right side. (Fig. A)
- 2** Remove (2) T-20 Torx screws from under the left side cover on the speedometer panel and (1) from under the right side cover on the a/c vent. (Fig. B)
- 3** Unclip and remove the panel from the passenger side of the dashboard facing the door. (Fig. C)

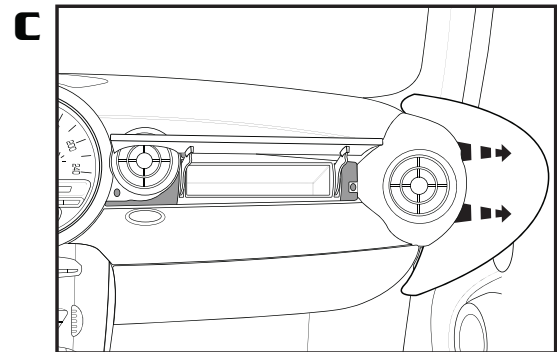
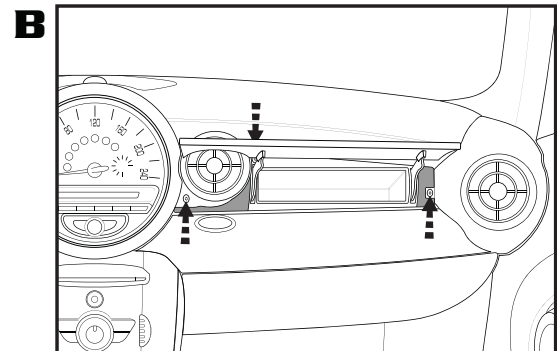
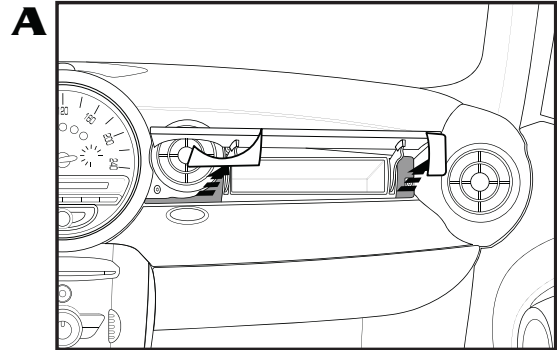

Continue to PG.2.....

## 99-9309 DASH DISASSEMBLY

### MINI COOPER

- 4** Remove (2) T-20 Torx screws from the passenger side a/c vent facing the door then unclip the vent and let it hang. (Fig. D)
- 5** Remove (2) T-30 Torx screws securing the tachometer to the steering column and let hang. (Fig. D)
- 6** Unclip and remove the painted panel behind the tachometer. (Fig. E)
- 7** Remove (2) T-20 Torx screws from the speedometer panel. (Fig. F)

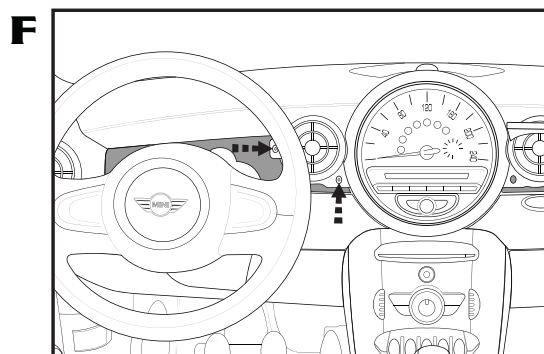
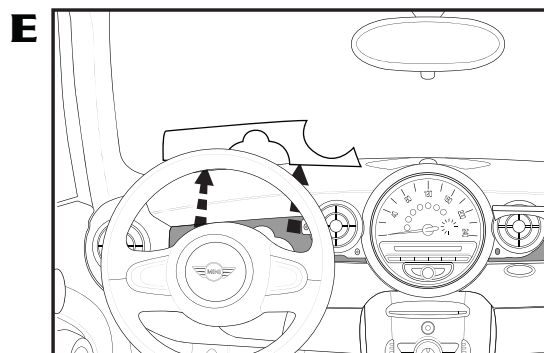
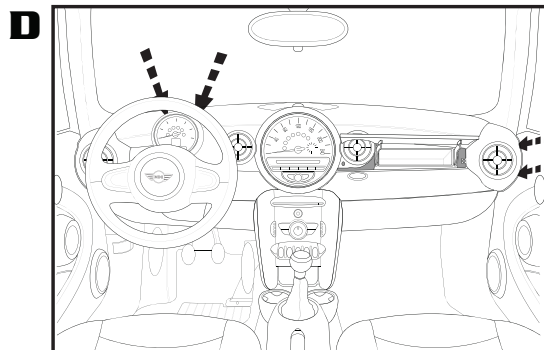

Continue to PG.3.....

## 99-9309 DASH DISASSEMBLY

### MINI COOPER

- 8** Remove the (2) screw covers inside the vent above the speedometer then remove the (2) T-20 Torx screws uncovered. (Fig. G)
- 9** Remove the speedometer trim panel and disconnect hazard switch. (Fig. H)
- 10** Remove (3) T-20 Torx from under drive knee bolster and remove panel. (Fig. H)
- 11** Remove panels from driver and passenger side of center stack. Remove (2) T-20 Torx from each side of center stack. (Fig. I)
- 12** Unclip trim panel from bottom of center stack and remove (1) T-30 Torx. (Fig. I)

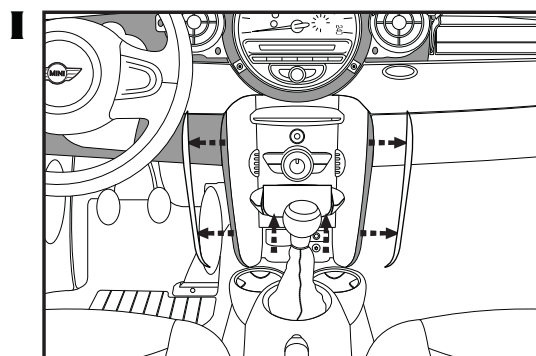
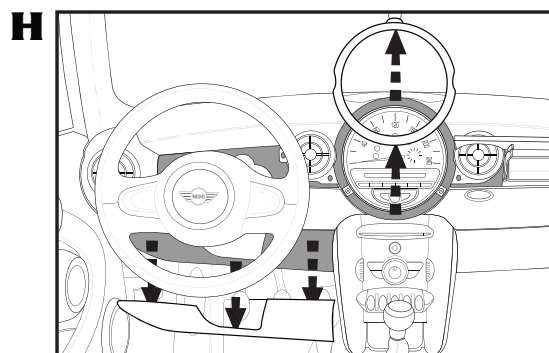
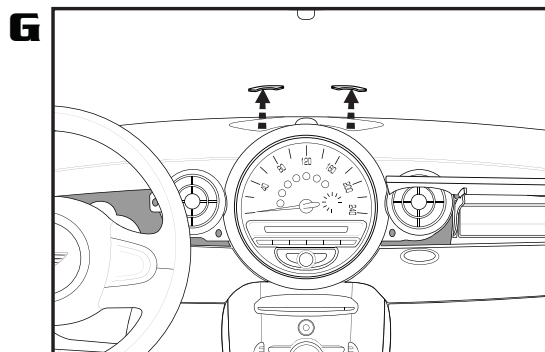

Continue to PG.4.....

## 99-9309 DASH DISASSEMBLY

### MINI COOPER

**13** Remove (3) T-20 Torx from cup holders in center console. Unclip shifter and handbrake boots and remove connectors from 12-volt outlet and buttons in front of shifter. Lift console and remove. (Fig. J)

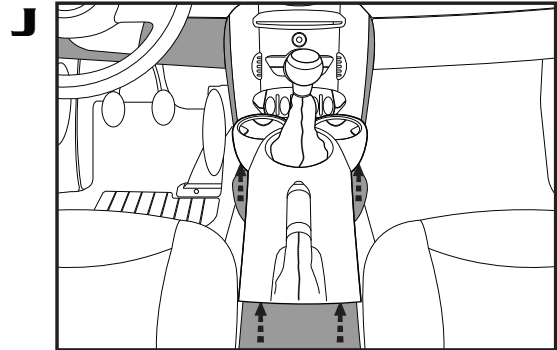

**14** Unclip center stack and unplug connectors from climate controls, aux jack and window switches. Remove (4) T-20 Torx securing climate controls and window switches to center stack. Place aside. (Fig. K)

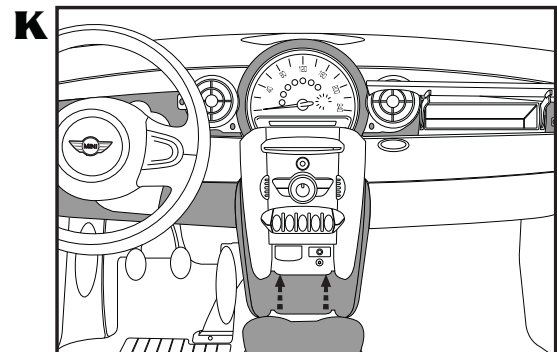

**15** Remove (4) T-20 Torx from keyhole panel. Unclip panel and let it hang. (Fig. L)

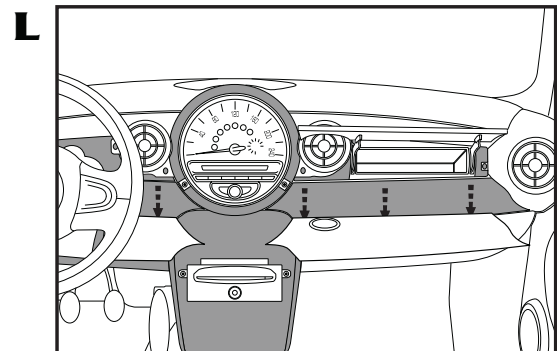

**16** Remove (5) T-20 Torx from panel between glove boxes and unclip panel. (Fig. L)

Continue to PG.5.....



## 99-9309 DASH DISASSEMBLY

### MINI COOPER

- 17** Remove (3) T-20 Torx from speedometer and (2) from radio chassis. (Fig. M)
- 18** Unplug speedometer and radio chassis. Remove assembly.
- 19** Remove (4) T-20 Torx from rear of speedometer and remove radio display/control panel from cluster.

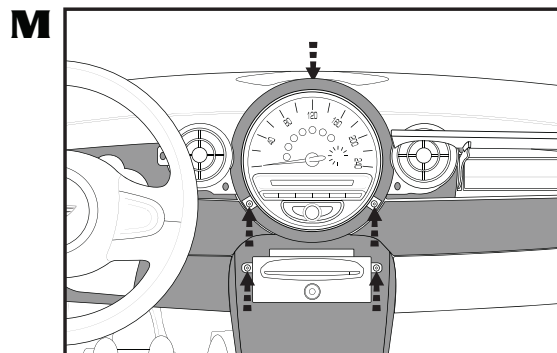

Continue to Kit Preparation.....



## 99-9309 KIT PREPARATION

### MINI COOPER

- 1** Place blank out plate from kit in speedometer and secure using (4) T-20 Torx removed in step 19. (Fig. A)
- 2** On vehicles without automatic climate control place button blanks in kit before securing climate/window controls in kit using (4) T-20 Torx removed in step (16). (Fig. B)
- 3** If desired, mark trim panel removed in step (14)  $\frac{1}{2}$ " above bend and trim off top portion for use after installation is completed. (Fig. C)

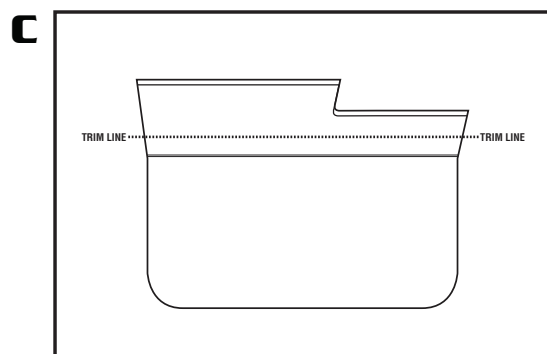
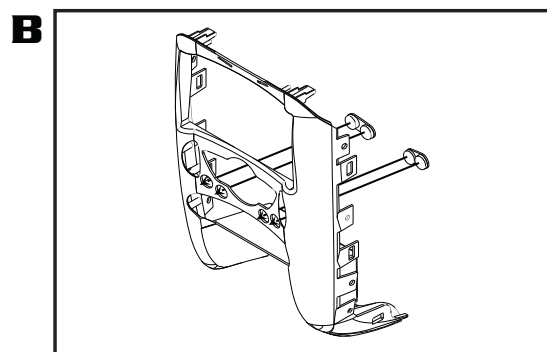
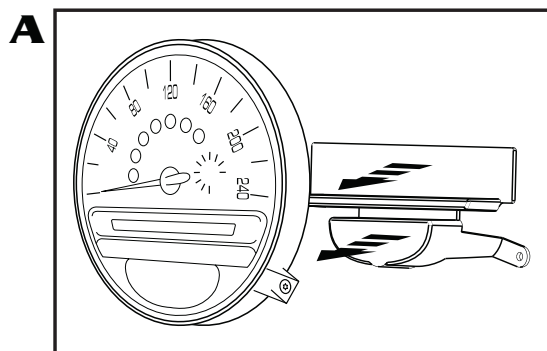



## 99-9309 KIT ASSEMBLY

### ISO DIN HEAD UNIT PROVISION

- 1** Attach left and right radio housing brackets to pocket with four #8 3/8" Phillips screws provided. (Fig. A)
- 2** Secure radio housing brackets and pocket to kit with four #8 3/8" Phillips screws provided. (Fig. B)
- 3** Align the holes in the radio housing brackets with the holes in the ISO DIN and secure the brackets to the head unit with the screws included with the unit. (Fig. C)
- 4** Locate the factory wiring harness and antenna plug in the dash. Metra recommends using the proper mating adapters from Metra and/or AXXESS.
- 5** Reassemble dash in reverse order of disassembly using the 99-9309 radio trim panel instead of the factory center stack panel.

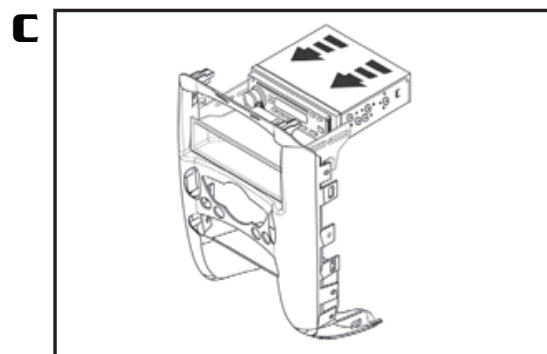
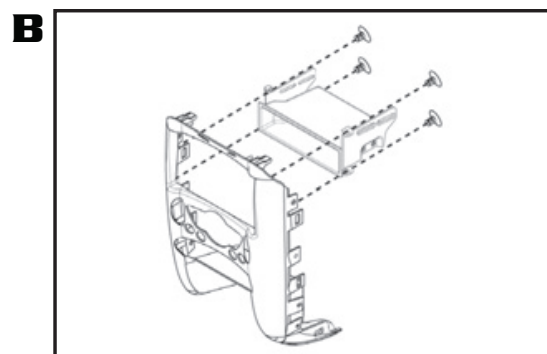
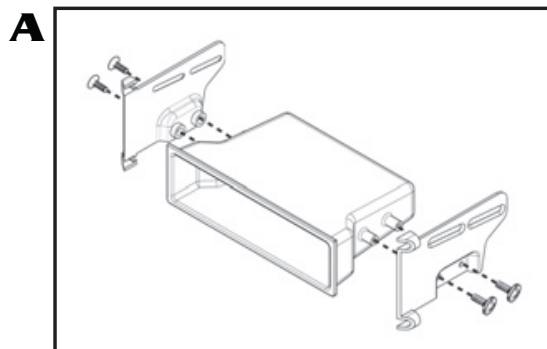



## 99-9309 KIT ASSEMBLY

# DDIN / STACKED ISO DIN HEAD UNIT PROVISION

- 1** Secure Double DIN brackets to the inside edge of the kit with (4) 3/8" Phillips screws provided. (Fig. A)
- 2** Slide the Double DIN head unit or stacked ISO head units into the bracket/radio housing assembly and secure the Double DIN head unit or stacked ISO head units to the assembly using the screws supplied with the radio. (Fig. B)
- 3** Locate the factory wiring harness and antenna plug in the dash. Metra recommends using the proper mating adapters from Metra and/or AXXESS.
- 4** Reassemble dash in reverse order of disassembly using the 99-9309 radio trim panel instead of the factory center stack panel.

