



120999501B



2283353 05-14-10

INSTALLATION INSTRUCTIONS FOR PART 99-9501

APPLICATIONS
JAGUAR S-TYPE
2003-2008
JAGUAR X-TYPE
2002-2008
(NON-NAV MODELS)

99-9501B

99-9501G

KIT FEATURES

- DIN Head Unit Provision w/ removable pocket
- ISO DIN Head Unit Provision w/ removable pocket
- DDIN Head Unit Provision
- ISO Stacked Head Unit Provision
- TWO FINISHES AVAILABLE:
99-9501B=BLACK, 99-9501G=GREY



KIT COMPONENTS

- A) Radio Housing B) ISO Brackets C) ISO Trim Plate D) DDIN Brackets E) DDIN Trim Plate
F) Pocket G) (2) Pocket C-Clips H) (2) Small Phillips screws

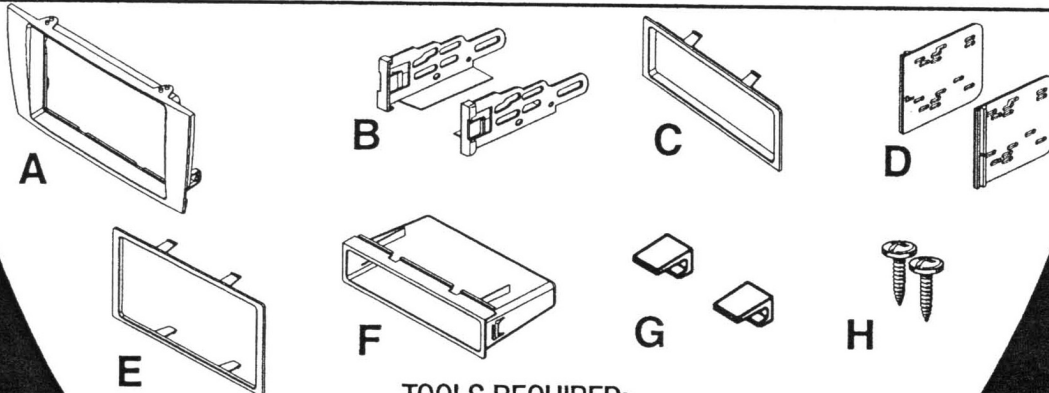

TOOLS REQUIRED:

- Small Flat Blade Screwdriver • Torx Screwdriver
- Socket Wrench • Cutting Tool

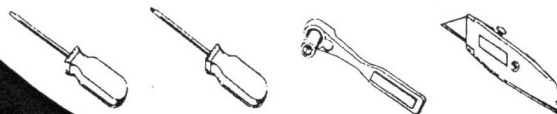

METRA. THE WORLD'S BEST KITS.™



1-800-221-0932



www.metraonline.com

© COPYRIGHT 2007-2009 METRA ELECTRONICS CORPORATION

TABLE OF CONTENTS

Dash Disassembly

- **Jaguar S-Type 2003-2008 1,2**
- **Jaguar X-Type 2002-2008 3,4**

Kit Preparation

- **Jaguar S-Type 2003-2008 5**
- **Jaguar X-Type 2002-2008 5**

Kit Assembly

- **DIN Head Unit Provision. 6**
- **ISO DIN Head Unit Provision. 7**
- **DDIN Head Unit Provision. 8**

***Note:**

Refer also to the instructions included with the aftermarket radio.

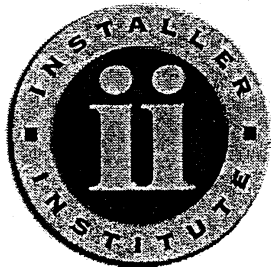

KNOWLEDGE IS POWER

Enhance your installation and fabrication skills by enrolling in the most recognized and respected mobile electronics school in our industry. Log onto www.installerinstitute.com or call 800-354-6782 for more information and take steps toward a better tomorrow.



Metra recommends MECP certified technicians.

JAGUAR S-TYPE 2003-2008**NON-NAV MODELS**

- 1** Disconnect the negative battery terminal to prevent an accidental short circuit.
- 2** Remove cup holder and (2) screws securing center console storage compartment and remove compartment. (Figure A)
- 3** Unclip and remove the trim panel around the shifter. (Figure B)

Continued on page 2

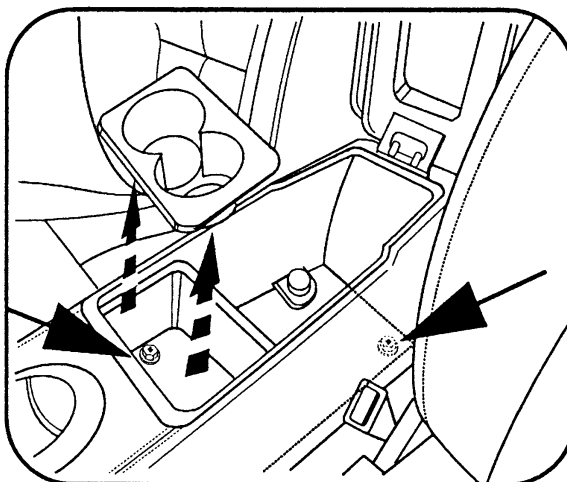
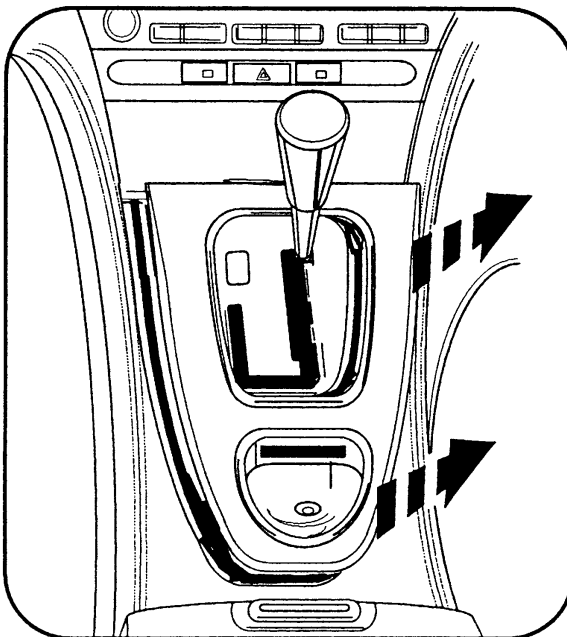
A**B**

JAGUAR S-TYPE 2003-2008**NON-NAV MODELS**

4 Unclip and remove the trim panel surrounding the radio/climate controls/ashtray and front half of the center console. (Figure C)

5 Remove (4) screws securing the radio/climate control assembly to the dash. Unplug and remove assembly. (Figure D)

6 Remove (4) screws securing the radio to the assembly and remove the radio. Retain the assembly for re-use during kit assembly.

Continue to kit assembly

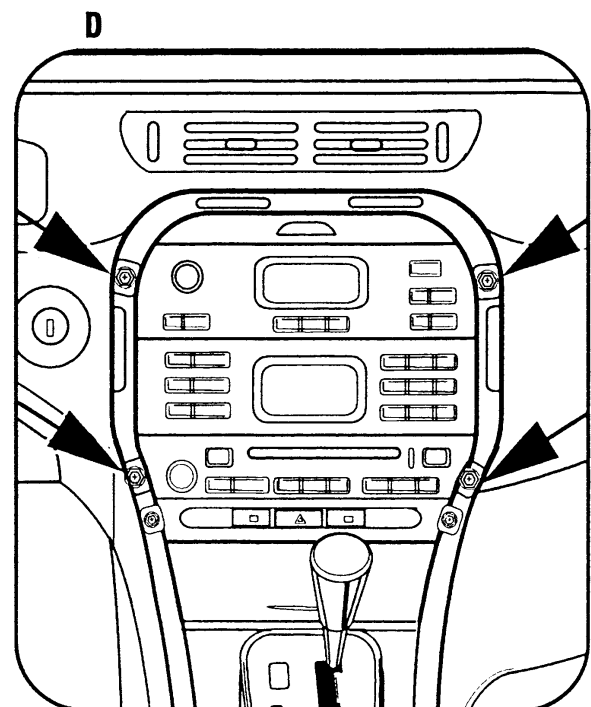
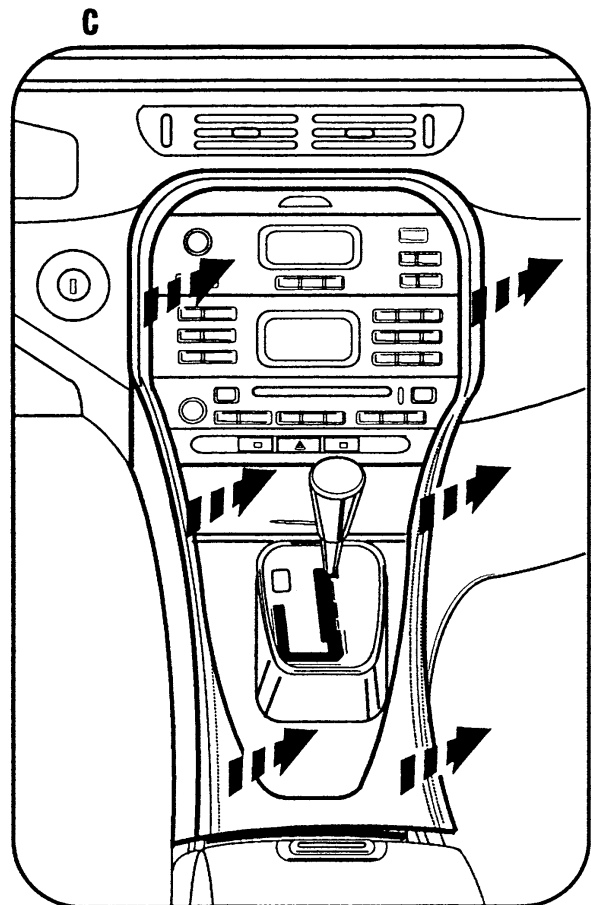

JAGUAR X-TYPE 2002-2008**NON-NAV MODELS**

- 1 Disconnect the negative battery terminal to prevent an accidental short circuit.
- 2 Unclip and remove the trim panel around the shifter. (Figure A)
- 3 Remove (2) screws from bottom edge of ashtray assembly then unclip and remove ashtray assembly. (Figure B)
- 4 Remove (2) screws from inside ashtray cavity at bottom edge of radio. (Figure C)

Continued on page 4

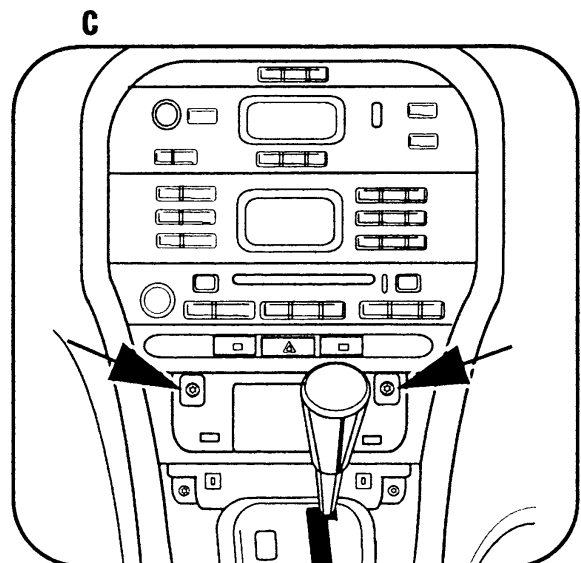
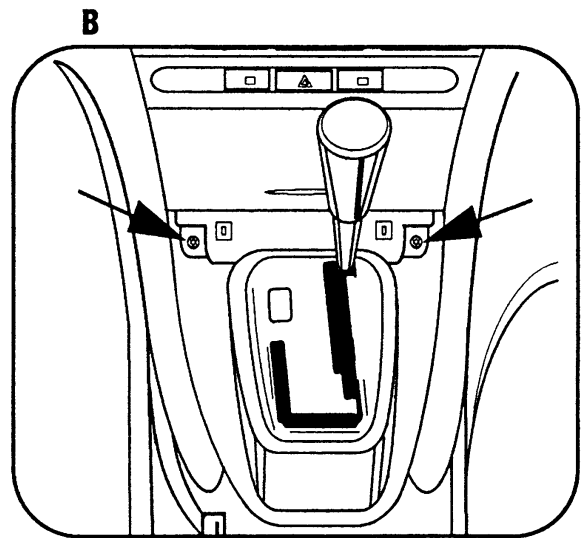
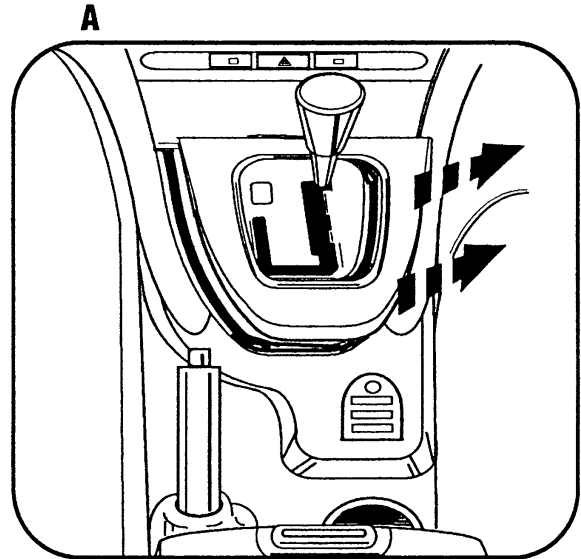

JAGUAR X-TYPE 2002-2008**NON-NAV MODELS**

- 5 Unclip, unplug and remove hazard switch/seat heater switch trim panel above climate control/radio assembly. (Figure D)
- 6 Remove (2) screws from inside switch panel cavity at top edge of climate controls. (Figure E)
- 7 Unplug and remove the climate control/radio assembly. (Figure F)
- 8 Remove (4) screws securing the radio to the assembly and remove the radio. Retain the assembly for re-use during kit assembly.

Continue to kit assembly

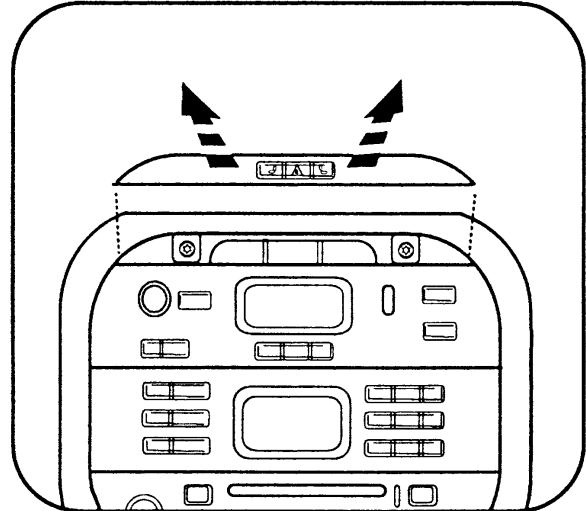
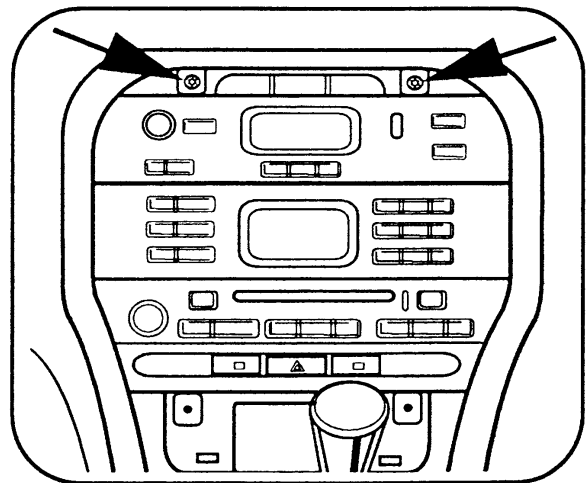
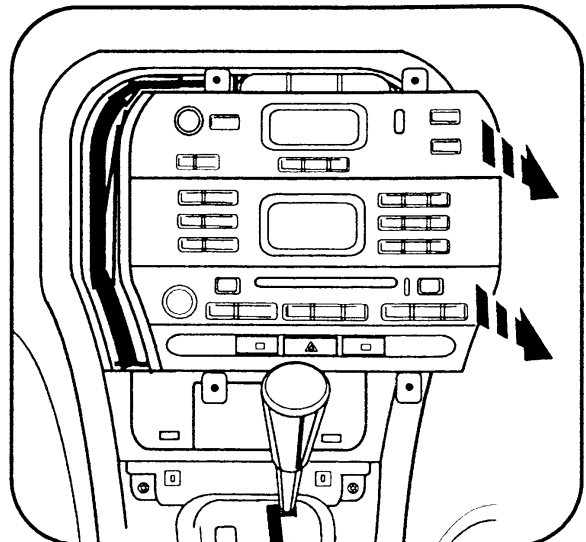
D**E****F**

KIT PREPARATION**JAGUAR S-TYPE 2003-08**

Cut and remove the locator closest to the face of the radio housing for the S-Type. (Figure A)

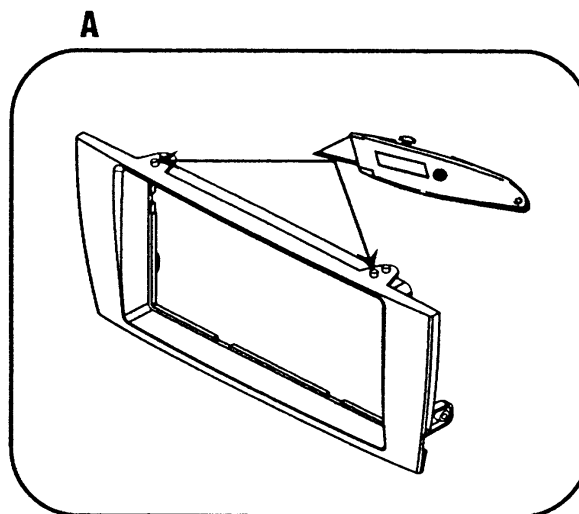
**JAGUAR X-TYPE 2002-08**

Cut and remove the locator farthest from the face of the radio housing for the X-Type. (Figure B)

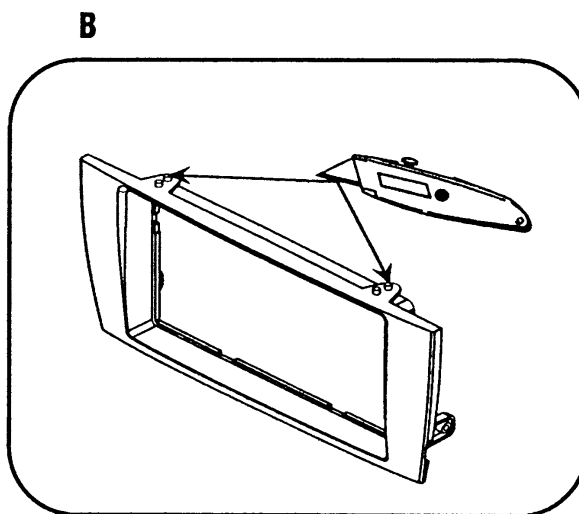

Continue to kit assembly

JAGUAR S-TYPE 2003-2008
JAGUAR X-TYPE 2002-2008**DIN HEAD UNIT PROVISION**

- 1 Locate the factory wiring harness in the dash. Metra recommends using the proper mating adapter from Metra or AXCESS. Re-connect the negative battery terminal and test the unit for proper operation.
- 2 Slide the DIN cage into the Radio Housing and secure by bending the metal locking tabs down. (Figure A)
- 3 Snap the pocket into the bottom opening of the radio housing. (Figure B)
- 4 Secure the pocket by inserting the c-clips into the opening between the pocket and the bottom of the radio housing. (Figure B)
- 5 Slide the aftermarket head unit into the cage and secure. (Figure C)
- 6 Attach the radio housing to the climate control bracket assembly and screw the bottom together with the two supplied Phillips screws.
- 7 Reassemble dash in reverse order of disassembly.

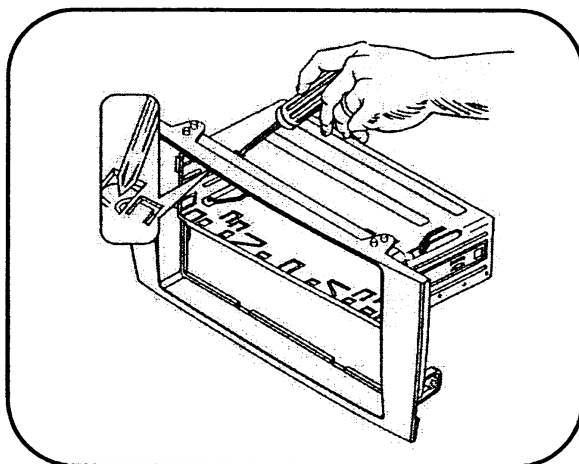
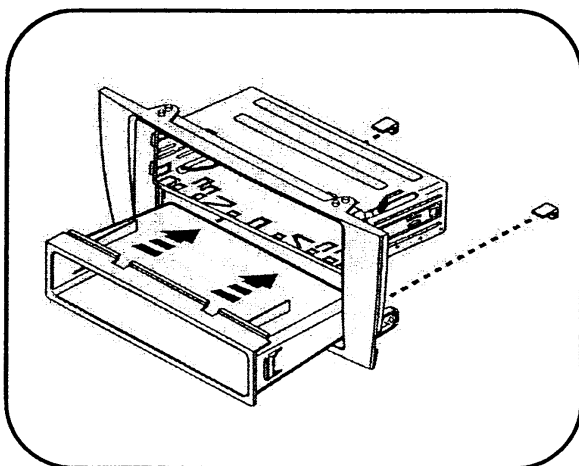
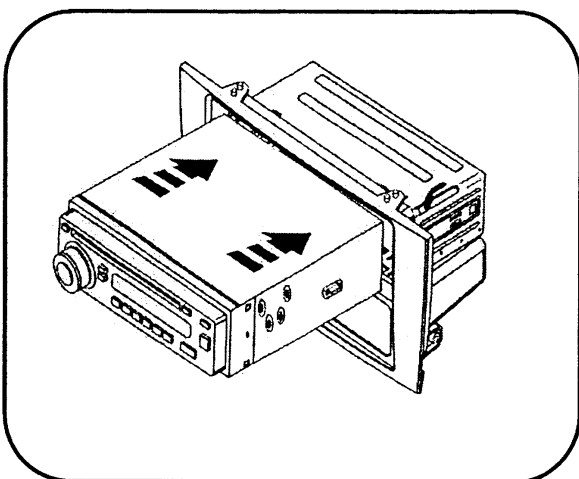
A**B****C**

JAGUAR S-TYPE 2003-2008
JAGUAR X-TYPE 2002-2008**ISO DIN HEAD UNIT PROVISION**

- 1 Locate the factory wiring harness in the dash. Metra recommends using the proper mating adapter from Metra or AXCESS. Re-connect the negative battery terminal and test the unit for proper operation.
- 2 Mount the ISO Brackets to the head unit with the screws supplied with the unit. (Figure A)
- 3 Snap the pocket into the bottom opening of the radio housing. (Figure B)
- 4 Secure the pocket by inserting the c-clips into the opening between the pocket and the bottom of the radio housing. (Figure B)
- 5 Slide the head unit into the radio opening until the side clips engage. (Figure C)
- 6 Snap the Trim plate into the Radio Housing. (Figure C)
- 7 Attach the radio housing to the climate control bracket assembly and screw the bottom together with the two supplied Phillips screws.
- 8 Reassemble dash in reverse order of disassembly.

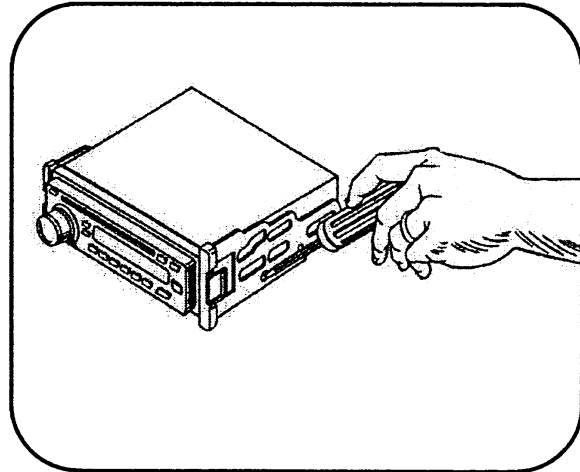
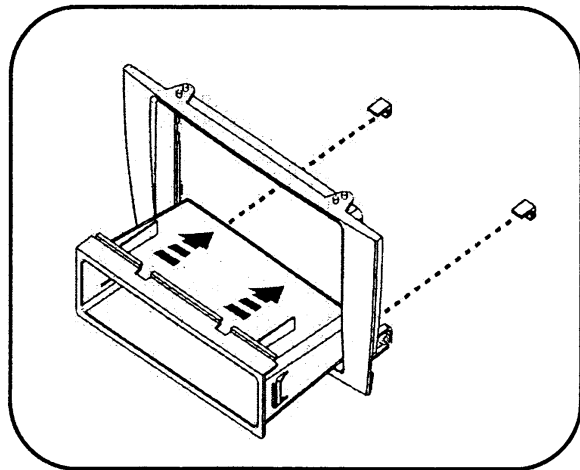
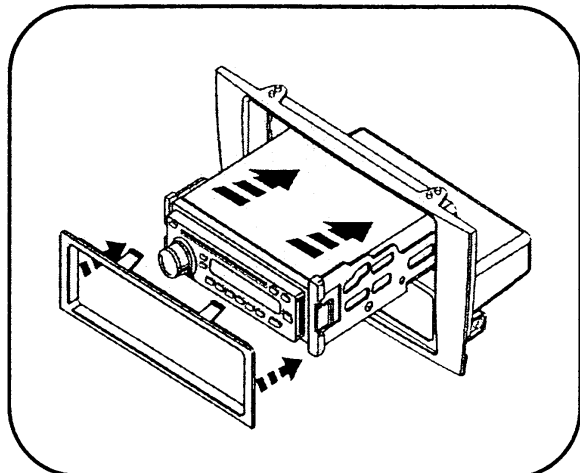
A**B****C**

JAGUAR S-TYPE 2003-2008**JAGUAR X-TYPE 2002-2008****DDIN HEAD UNIT PROVISION**

- 1 Locate the factory wiring harness in the dash. Metra recommends using the proper mating adapter from Metra or AXXESS. Re-connect the negative battery terminal and test the unit for proper operation.
- 2 Snap the Double DIN brackets to the inside edge of the Radio Housing. (Figure A)
- 3 Slide the Double DIN head unit or stacked ISO head units into the bracket/radio housing assembly and secure the Double DIN head unit or stacked ISO head units to the assembly using the screws supplied with the radio. (Figure B)
- 4 Snap the double DIN trim plate into the radio housing. (Figure B)
- 5 Attach the radio housing to the climate control bracket assembly and screw the bottom together with the two supplied Phillips screws
- 6 Reassemble dash in reverse order of disassembly.

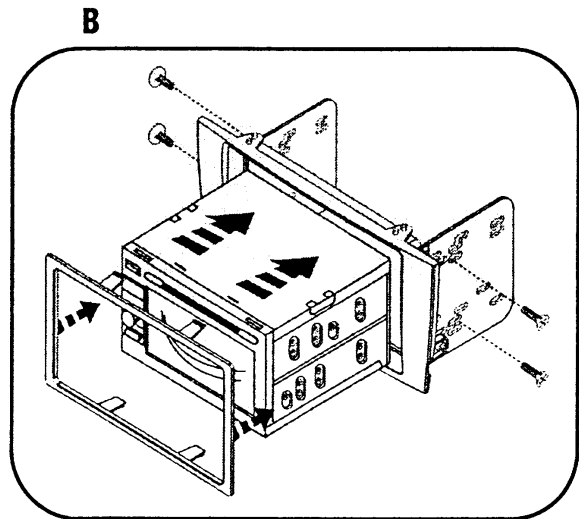
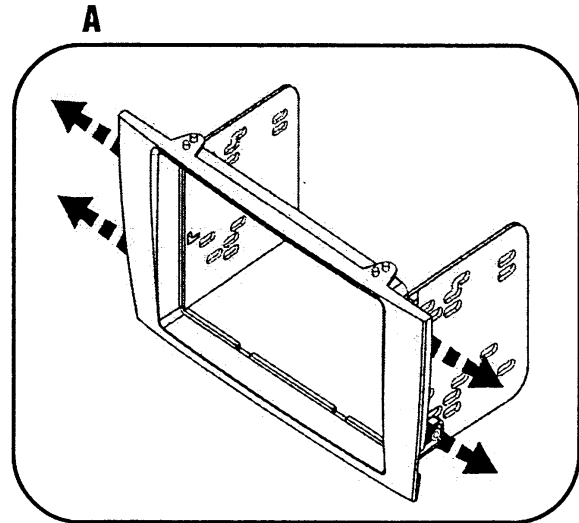

99-9501 INSTRUCTIONS

METRA. THE WORLD'S BEST KITS.™



1-800-221-0932



www.metraonline.com

REV. 12/08/09 © COPYRIGHT 2003-2009 METRA ELECTRONICS CORPORATION INST99-9501