

Installation Kit

DIN Assembly

IMPORTANT

Before starting, compare items on your invoice with items received. If any parts are missing, first carefully check through packaging material. If an item is missing, please call: **Crutchfield at 1-888-955-6000**

003 FMK549

Ford

Revision 06/09/99

Page 1 of 2

1. Using a utility knife, cut out the **shaft supports** in the **receiver mounting bracket** to create the DIN opening as shown in Figure 1.
2. Remove **DIN sleeve** from receiver. Slide DIN sleeve into receiver mounting bracket and secure by bending **securing tabs** (Figure 2).
3. Slide receiver fully into sleeve.
4. Secure **rear support bracket** to rear of receiver as shown using hardware supplied with receiver.
5. Install receiver assembly in dash of vehicle following instructions in the Mastersheet for your vehicle.

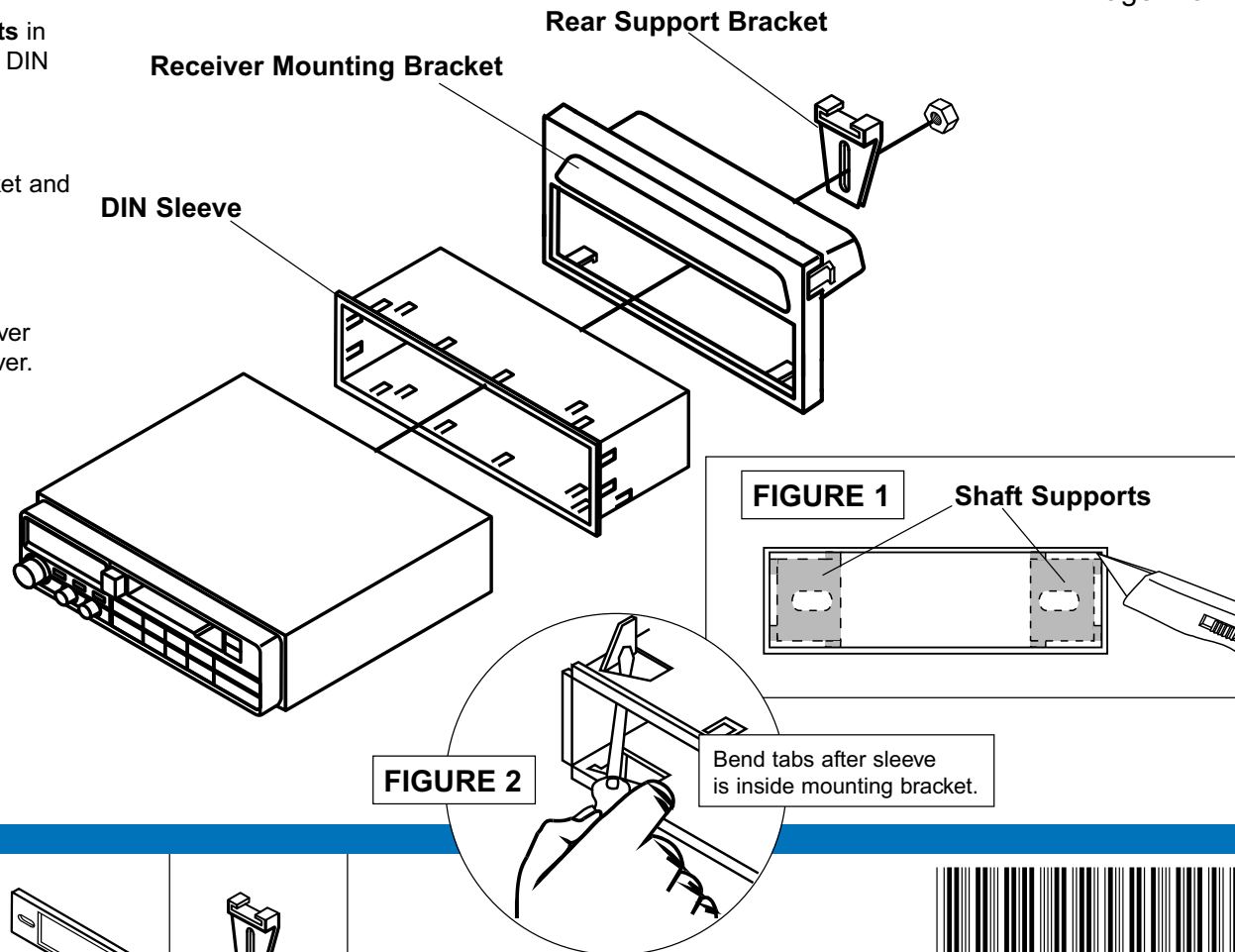

Tools Required

Flat Blade
Screwdriver

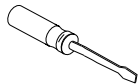

Utility
Knife

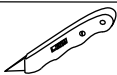

Parts Supplied:

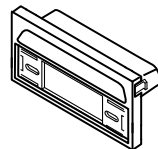

Mounting
Bracket

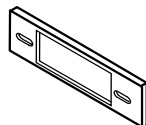

Receiver
Trimplate
(for shaft receiver only)



Rear Support
Bracket



CRUTCHFIELD®

Copyright 1999 Crutchfield Corporation

Installation Kit

003 FMK549

Ford

Shaft Assembly

Page 2 of 2

1. Choose the correct **spacers** (supplied with your order) from the shaft spacer tree which will allow receiver nosepiece to extend $1/8"$ to $1/4"$ beyond face of **receiver mounting bracket** (see Inset).
2. Secure receiver, **trimplate**, and **faceplate** to **receiver mounting bracket** using **shaftnuts** as shown.
3. Secure **rear support bracket** to rear of receiver using hardware supplied with receiver.
4. Install receiver assembly in dash of vehicle following instructions in the Mastersheet for your vehicle.

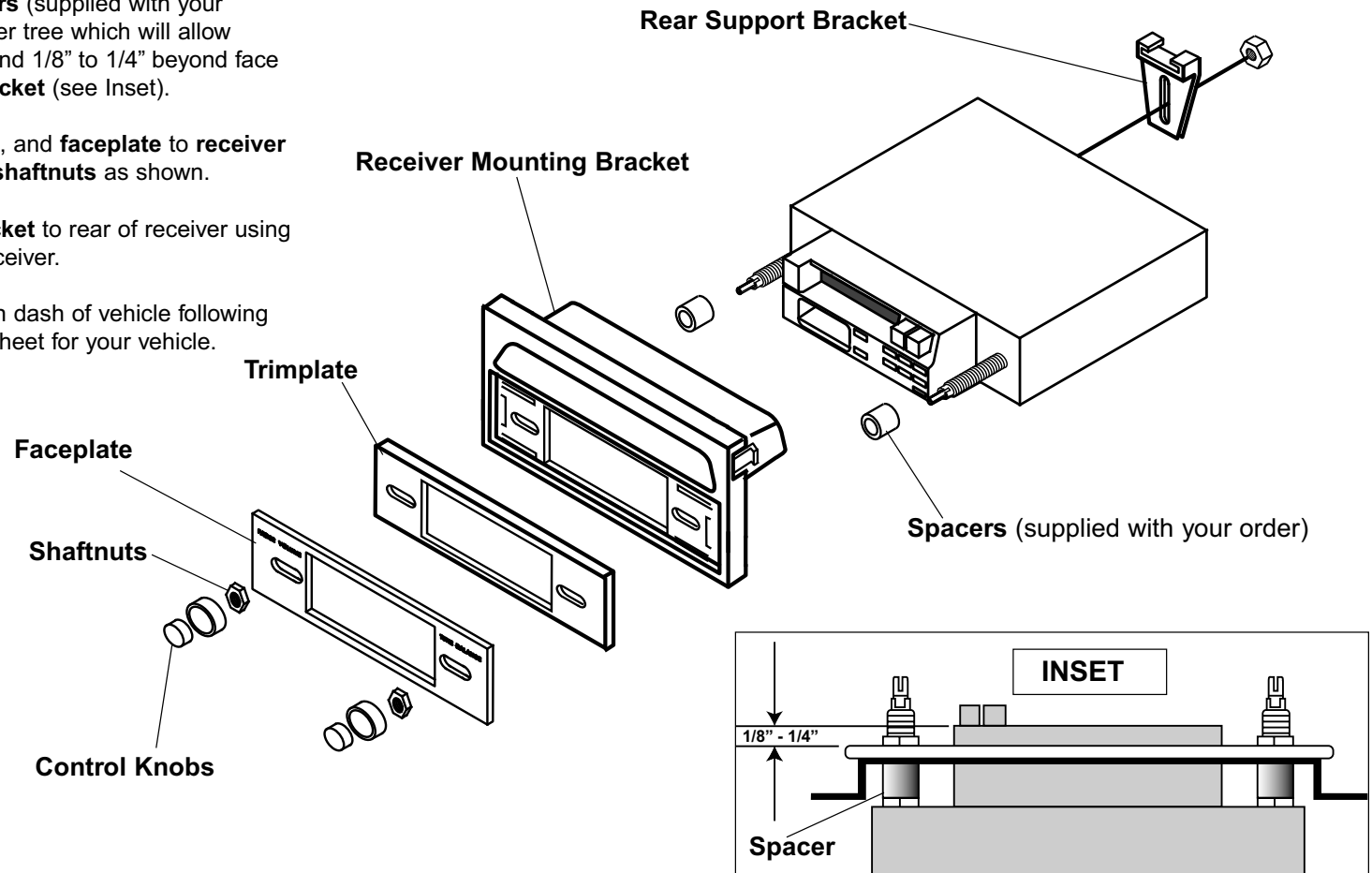

Tools Required



Deep
Socket



(size depends upon receiver)

CRUTCHFIELD[®]

Copyright 1999 Crutchfield Corporation