



Pacific Accessory Corporation

# TATO

## JBL Amplifier Turn-On Interface for Toyota CANbus Vehicles



**The TATO is designed to control the power and audio levels of the factory installed JBL amplifier allowing the OEM radio to be removed and replaced with an aftermarket stereo.**

### Installation:

**Note: BEFORE REMOVING THE FACTORY RADIO: BALANCE AND FADE IT TO THE CENTER, TURN THE RADIO UP TO AT LEAST 3/4 VOLUME, TURN THE RADIO OFF, TURN THE IGNITION OFF & THEN PROCEED WITH REMOVING THE FACTORY RADIO**

Disconnect the factory radio from the OEM wiring harness and remove it from the vehicle. Make the following connections of the TATO wiring harness to the aftermarket radio:

### Connections:

- Yellow Wire - Connect to 12 Volt Constant Power on aftermarket radio
- Red Wire - Connect to Accessory on aftermarket radio
- Black Wire - Connect to Ground on aftermarket radio
- Orange/White Wire - Connect to Dimmer on aftermarket radio
- \*11 Pin Harness - Connect to PAC's SWI-X, SWI-JACK, SWI-PS or SWI-ECL2 (Sold Separately)
- Red Bullet Connector - Connect to Accessory
- Black Bullet Connector - Connect to Ground
- Connect the 4 RCA connectors to the RCA outputs of the aftermarket radio
  - Front Left - White RCA      Front Right - Grey RCA
  - Rear Left - Green RCA      Rear Right - Purple RCA

*If connecting the TATO to a head unit with only 2 Channel RCA outputs, use two pairs of RCA splitters (1M-2F) to split the signal. Failure to connect all 4 inputs of the TATO will result in loss of audio performance. Fade audio controls will only function with a 4 channel aftermarket deck.*

### Connections to the TATO Interface:

- Connect 24-pin translucent connector to the side of the TATO.
- Connect 8-pin DIN cable to the plug on the side of the TATO.

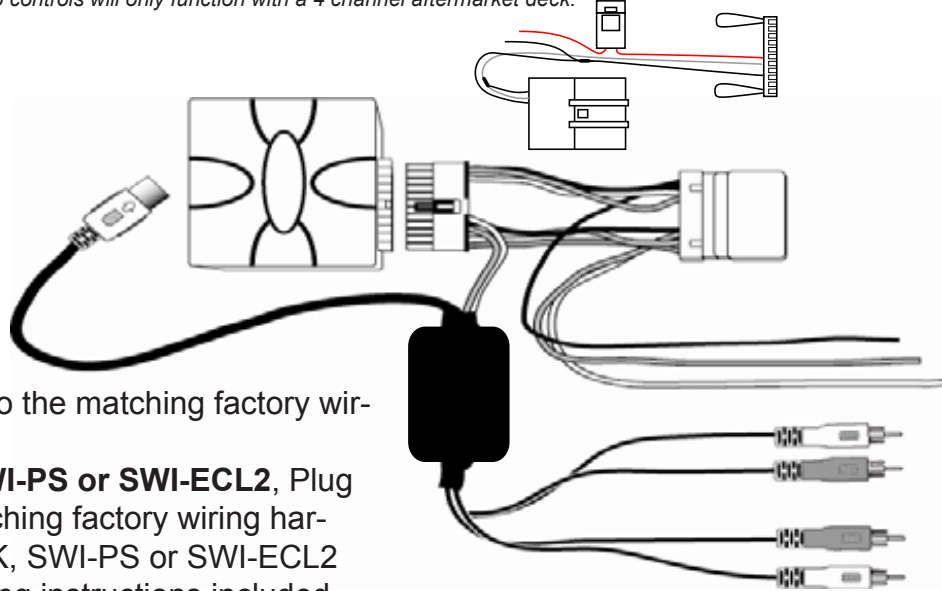

### Connections to the Vehicle:

- Plug the main 20-pin Toyota harness into the matching factory wiring harness.
- **\*If using PAC's SWI-X, SWI-JACK, SWI-PS or SWI-ECL2**, Plug the smaller 20-pin harness into the matching factory wiring harness. Program PAC's SWI-X, SWI-JACK, SWI-PS or SWI-ECL2 for version #8 and follow the programming instructions included with PAC's SWI-X, SWI-JACK, SWI-PS or SWI-ECL2.

**DISCLAIMER:** Under no circumstances shall the manufacturer or the distributors of the TATO be held liable for consequential damages sustained in connection with the TATO. The manufacture and it's distributors will not, nor will they authorize any representative or any other individual to assume obligation or liability in relation to the TATO other than its replacement.

## Adjusting Volume Output:

When initially connecting the TATO to the vehicle the max output might not meet that of the factory radio. If the volume is low you can adjust the output using the dip switches on the side of the module. It is recommended to use a 4 volt RMS capable aftermarket radio. When adjusting the gain output it is recommended to start with the plus 7dB setting and working your way down.

**Note:** It may take up to 10 seconds before the gain adjustment is heard.

## The dB gain adjustments are as follows:

Dip Switch Settings			
Dip Switch 1	Dip Switch 2	Dip Switch 3	dB Gain
Off	Off	Off	Plus 0dB
On	Off	Off	Plus 1dB
Off	On	Off	Plus 2dB
On	On	Off	Plus 3dB
Off	Off	On	Plus 4dB
On	Off	On	Plus 5dB
Off	On	On	Plus 6dB
On	On	On	Plus 7dB

**Set all other dip switches 4-8 to OFF (up) position**

### Troubleshooting

Symptom	Resolution
No audio from rear speakers	all 4 RCA connections on the TJA need to be connected to the Aftermarket head unit
No fade from front to back	Only a head unit with 4 RCA outputs will provide fade control
No audio through any speakers	Check the Dip Switches on the side of the TJA interface. Verify they are all "OFF" (Up)

### Warranty:

One Year Limited Warranty

The quality controls used in the manufacture of this product will ensure your satisfaction. This warranty applies only to the original purchaser of this product from an authorized Pacific Accessory Corporation dealer. This warranty covers any supplied or manufactured parts of this product that, upon inspection by Pacific Accessory Corporation authorized personnel, is found to have failed in normal use due to defects in material or workmanship. This warranty does not apply to installation expenses. Attempting to service or modify this unit, operating this unit under conditions other than the recommended voltage will render this WARRANTY VOID. Unless otherwise prescribed by law, Pacific Accessory Corporation shall not be liable for any personal injury, property damage and or any incidental or consequential damages of any kind (including water damage) resulting from malfunctions, defects, misuse, improper installation or alteration of this product.

All parts of this Pacific Accessory Corporation product are guaranteed for a period of 1 year as follows: Within the first 12 months from date of purchase, subject to the conditions above, Pacific Accessory Corporation will repair or replace the product at their discretion, if it is defective in material or workmanship providing it is returned to an Authorized Pacific Accessory Corporation Dealer, with PROOF OF PURCHASE from an authorized Pacific Accessory Corporation dealer.

### Warning:

This equipment may be reset by unintentional electrostatic discharge during operation. Exposure to direct sunlight or extreme heat may cause damage or malfunction.

FCC Class B Radio Frequency

### Interference Statement:

This equipment has been tested and found to comply with the limits for a Class B digital device, pursuant to Part 15 of FCC rules. These limits are designed to provide reasonable protection against harmful interference in a residential installation. This equipment generates, uses, and can radiate radio frequency energy and, if not installed and used in accordance with the instructions, may cause harmful interference to radio communications. However, there is no guarantee that interference will not occur in a particular installation. If this equipment does cause harmful interference to radio or television reception, which can be determined by turning the equipment off and on, the user is encouraged to try to correct the interference by one or more of the following measures:

1. Re-orientate or relocate the receiving antenna.
2. Increase the separation between the equipment and receiver.
3. Connect the equipment into an outlet on a circuit different from that of which the receiver is connected.
4. Consult the dealer or an experienced radio / television technical for help

Notice : The changes or modifications not expressly approved by the party responsible for compliance could void the user authority to operate the equipment.

**DISCLAIMER:** Under no circumstances shall the manufacturer or the distributors of the TATO be held liable for consequential damages sustained in connection with the TATO. The manufacture and it's distributors will not, nor will they authorize any representative or any other individual to assume obligation or liability in relation to the TATO other than its replacement.



Pacific Accessory Corporation

## - Climate Controls do not function after replacing head unit in Prius -



**Symptoms:** Climate controls in the Toyota Prius are inoperable after replacing the head unit.

**Reason:** A rest resistance is no longer being read by the screen due to the factory radio being removed / replaced.

**Solution:** Locate the 20 pin white connector that has 5 wires in it that was plugged into the factory radio.

Find the small gauge white wire in pin 10 and the small gauge pink wire in pin 9.

Strip back the insulation on the white and pink wires, connect one side of a 68 OHM resistor to the white wire and connect the other side of the resistor to the pink wire.

When completed be sure to insulate the wires including the resistor to protect them from coming into contact with any metal, and secure the connector back in the dash cavity.

