

For information about other American International automotive accessories visit our website at:

<http://www.aius.net>

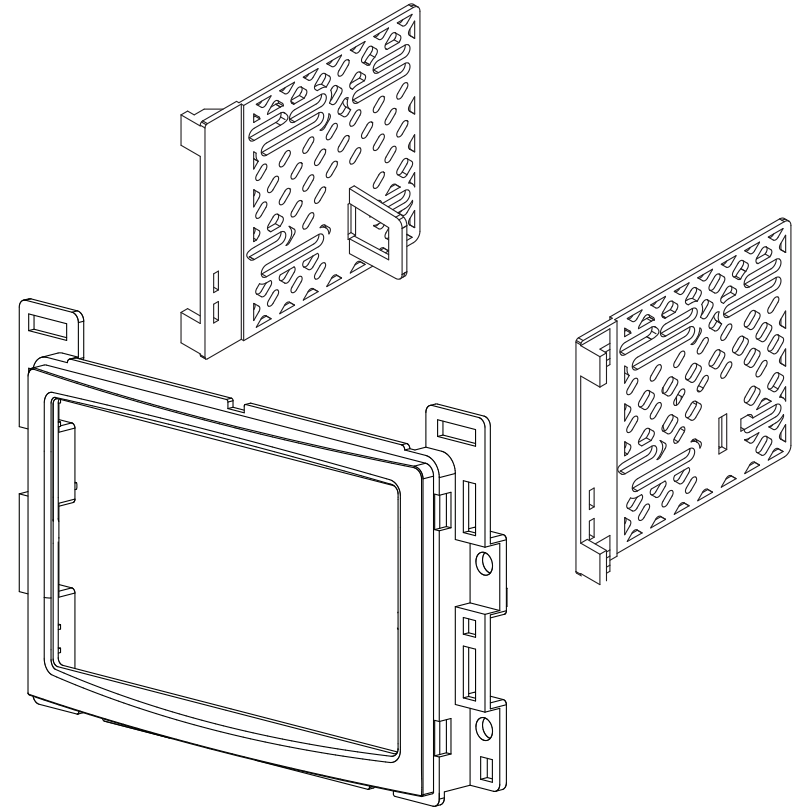

**American
International**
Car Stereo Installation Kits & Accessories



GMK352 Mounting Kit



American International

WWW.AIUS.NET

2500 East Francis Street Ontario, CA 91761, U.S.A.

USA Sales (800) 336-6500

Canada Sales (888) 922-3006

CUSTOMER HELP LINE

USA 800-323-4329 • Canada 800-245-8777

iGMK352

VEHICLE APPLICATIONS

Chevy

2005-10 COBALT
2005-06 EQUINOX
2006-11 HHR
2004-12 MALIBU
2004-07 MALIBU MAXX

Pontiac

2007-10 G5
2005-09 G6
2006-10 SOLSTICE
2006 TORRENT

Saturn

2007-09 AURA
2006-07 ION
2007-09 SKY
2006-07 VUE
SAAB
2007-08 9-7X

2007-2009 SATURN AURA

DASH DISASSEMBLY

Note: OEM amplifier located in rear passenger side trunk, underneath taillight

1. Remove the trim around the shift knob.
2. Remove panel with storage pocket, and unplug the power-outlet plug.
3. Remove the trim panel which goes across from the passenger side to the ignition switch and underneath/around the radio/climate controls. Note: you will need to unsnap the instrument cluster panel to allow trim panel to completely come out.
4. Remove the 6 (7mm) screws holding the radio and climate controls together.
5. Remove the radio and disconnect all plugs from the radio.

2007-2008 SATURN ION

DASH DISASSEMBLY

1. Remove the trim around the shift-knob.
2. Remove entire panel around the cup holders and shift-knob.
3. Disconnect the power-outlet plug from panel.
4. Starting at the bottom, underneath the climate controls, remove the dash panel surrounding the climate controls and radio (panel includes above 2-vents and storage pocket). Disconnect the hazards light switch and airbag light.
5. Remove 4 (7mm) screws holding the radio and disconnect the harnesses from the radio.

2006-2007 SATURN VUE

DASH DISASSEMBLY

1. Remove (by pulling upward) the entire panel (includes window switches) surrounding the shift-knob.
2. Disconnect the window switch and power-outlet plug(s).
3. Remove 4 (7mm) screws from storage pocket/seat heaters.
4. Starting at the bottom, pull panel (containing climate controls) and slowly work your way to the top. This part is all one piece from the bottom of the climate controls to the top of the dash above the radio.
5. Disconnect the climate control, hazard and passenger airbag light plug(s).

2006-2010 PONTIAC SOLSTICE

2007-2009 SATURN SKY

DASH DISASSEMBLY

1. Carefully pry outward and remove the cover plate from behind the center console handle on the right side of the console.
2. Remove the (2) 10 mm bolts securing the handle.
3. Using a fine edge panel removal tool, carefully pry the entire dash trim bezel outward.
4. Disconnect all harnesses attached to the rear of the trim bezel.
5. Carefully lean the entire trim bezel towards the driver's side and rest out of the way.
6. Remove the (4) screws securing the factory radio to the sub-dash, pull the radio forward, disconnect all harnesses and antenna lead and remove radio.

DOUBLE DIN MOUNT INSTALLATION INSTRUCTIONS

1. Attach left and right mounting brackets to the kit as shown in Figure B.
2. Insert ISO mountable radio between ISO mount brackets and loosely attach to sides of radio using screws provided with radio when possible or screws supplied with kit.
3. Slide radio forward or backward for desired look and tighten screws.
4. Support the rear of the radio component(s) with back strap (not included) optional.

