

For information about other American International automotive accessories visit our website at:

<http://www.aius.net>

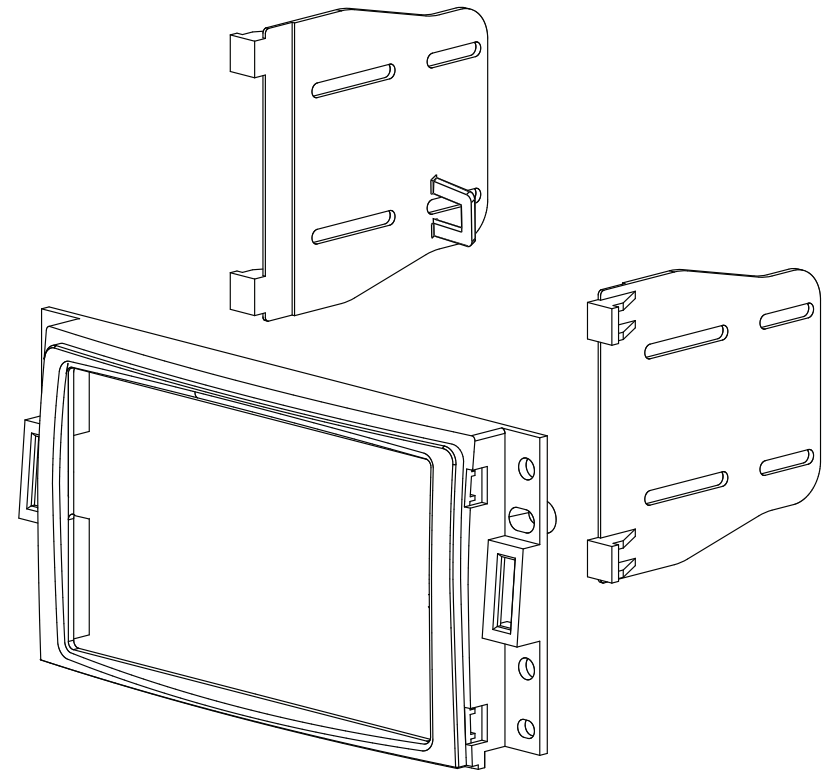

**American  
International**  
Car Stereo Installation Kits & Accessories



**GMK382 Mounting Kit**



**American International**

**WWW.AIUS.NET**

2500 East Francis Street Ontario, CA 91761, U.S.A.

USA Sales (800) 336-6500

Canada Sales (888) 922-3006

**CUSTOMER HELP LINE**

**USA 800-323-4329 • Canada 800-245-8777**

iGMK382

**VEHICLE APPLICATIONS**

**Buick**

2005-07 TERRAZA

**Chevy**

2005-13 CORVETTE

2005-08 UPLANDER

**Hummer**

2005-10 H3

2009-10 H3T

**Pontiac**

2005-06 MONTANA SV6

**Saturn**

2005-07 RELAY

**2005-07 BUICK TERRAZA / 2005-08 CHEVY UPLANDER  
2005-06 PONTIAC MONTANA SV6 / 2005-07 SATURN RELAY**

### **DASH DISASSEMBLY INSTRUCTIONS**

1. Carefully unclip the trim from around the radio/Climate controls and remove.  
(Use of a panel removal tool, or a right angle scribe tool is recommended).
2. Remove the (8) 9/32 or Phillips screws securing the Radio and Climate controls to the sub-dash.
3. Pull the Radio and Climate controls forward, lower and set the climate control out of the way, disconnect the wire harnesses and antenna lead from the rear of the factory radio and remove radio.

**2005-10 HUMMER H3/ 2009-10 HUMMER H3T**

### **DASH DISASSEMBLY**

1. Carefully remove trim from around radio.
2. Remove (4) 9/32 screws securing factory radio and climate controls to the sub-dash
3. Lay climate controls out of the way.
4. Pull radio and climate controls forward, disconnect all harnesses from radio and remove radio.

**2005-12 CHEVROLET CORVETTE**

### **DASH DISASSEMBLY**

1. Carefully lift up and remove the Ride Control switch/ cover plate located at the base of the center console, behind the Shifter.
2. Remove the (2) 9/32 screws located beneath the Ride Control/cover plate.
3. Carefully unfasten and remove the entire Radio/Climate Control trim bezel.
4. Remove the (4) 9/32 screws securing the radio to the sub-dash.
5. Pull the radio forward, disconnect all attached harnesses and antenna lead and remove radio.

### **DOUBLE DIN MOUNT INSTALLATION INSTRUCTIONS**

1. Remove support tab shown in Fig. B for double DIN radios only.
2. Attach left and right mounting brackets to the kit as shown in Figure C.
3. Insert ISO mountable radio between ISO mount brackets and loosely attach to sides of radio using screws provided with radio when possible or screws supplied with kit.
4. Slide radio forward or backward for desired look and tighten screws.
5. Support the rear of the radio component(s) with back strap (not included).

**Fig. B**

