

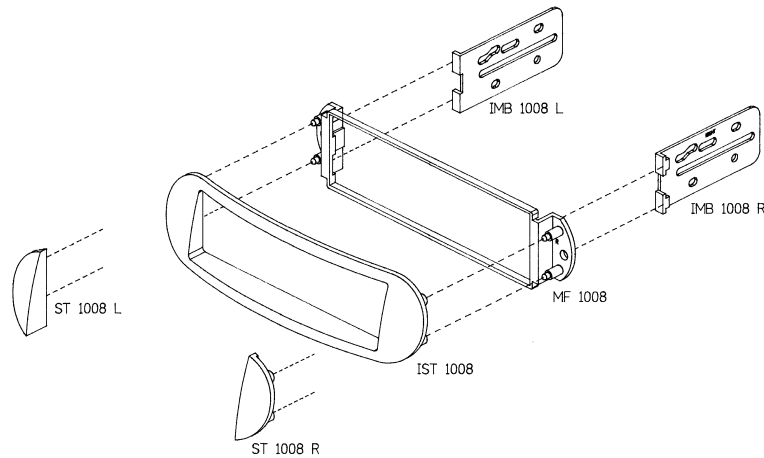

**American
International**
Car Stereo Installation Kits & Accessories



RADIO INSTALLATION INSTRUCTIONS

Step #1: Remove the factory radio using European import radio removal keys. (Not Included)

Step #2: Gently slide radio forward and disconnect antenna lead and wire harness.

DIN RADIO APPLICATIONS

1. Attach MF-1008 bracket to subdash locations using factory torx screws
2. Slide DIN sleeve into bracket and bend tabs to secure sleeve to trim
3. Mount radio into sleeve
4. Attach side trim pieces (ST-1008 L & R) to each side of mounting bracket

ISO MOUNT RADIO APPLICATIONS

1. Attach ISO brackets(IMB 1008 L & R) to sides of radio using special mounting screws supplied, leaving it loose to allow for adjustments of desired depth. Filing of side edges of subdash is necessary to allow mounting screws to slide past front edges. (PART NUMBER ON ISO BRACKETS MUST FACE OUTWARD!)
2. Attach IST-1008 trim plate to MF-1008 mounting bracket and place over face of radio.
3. Slide ISO brackets forward meeting rear of mounting bracket.
4. Slide radio forward to desired depth and tighten screws.
5. Connect all wiring.
6. Install radio into dash making sure that the sides of the ISO brackets lock over each edge of metal subdash.
7. Attach and mount MF-1008 bracket to dash using factory torx screws.
8. Press on the IST-1008 trim plate over radio face.



WWK1008 Mounting Kit

VEHICLE APPLICATIONS

VOLKSWAGEN
1998-11 BEETLE

For information about other American International automotive accessories visit our website at:

<http://www.americaninternational.net>

CUSTOMER HELP LINE
USA 800-323-4329 • Canada 800-245-8777

iVWK1008