

## DASH DISASSEMBLY & RADIO REMOVAL INSTRUCTIONS

1. Using Radio Removal keys, insert 1 key into each of the (2) key holes for single DIN radio with factory pocket equipped vehicles, or (4) key holes for Double DIN radio equipped vehicles.

**Note:** The flat side of the keys must face the outside edges of the radio.

2. Depress the keys slightly inward and pull the radio forward.
3. Disconnect the attached harness(s) and antenna lead and remove radio.
4. If the vehicle has the single DIN pocket, pull the pocket forward to remove, then if equipped, pull the radio/pocket divider tray out and remove.

## KIT ASSEMBLY INSTRUCTIONS

1. Insert the Double DIN audio/video component from the back of the VWK1015 installation kit, then loosely secure to the mounting brackets with the (8) counter sunk screws supplied with the radio or screws supplied with kit.
2. Slide the Audio/Video component forward or back for your desired look and tighten the screws.

**Note:** Some radio faces are larger in size than the VWK1015 allows. You may need to file the radio opening larger for some radios.

**WARNING NOTE:** You must completely wire and test the radio and all features and functions prior to installing the assembled kit and radio into the dash opening.

The dash opening of for these vehicles is extremely tight and may require some minor force to lock the assembled kit with radio into the dash opening. Once assembled and installed the kit is a very tight fit,

**REMOVAL WILL BE VERY DIFFICULT**



# American International

Car Stereo Installation Kits & Accessories

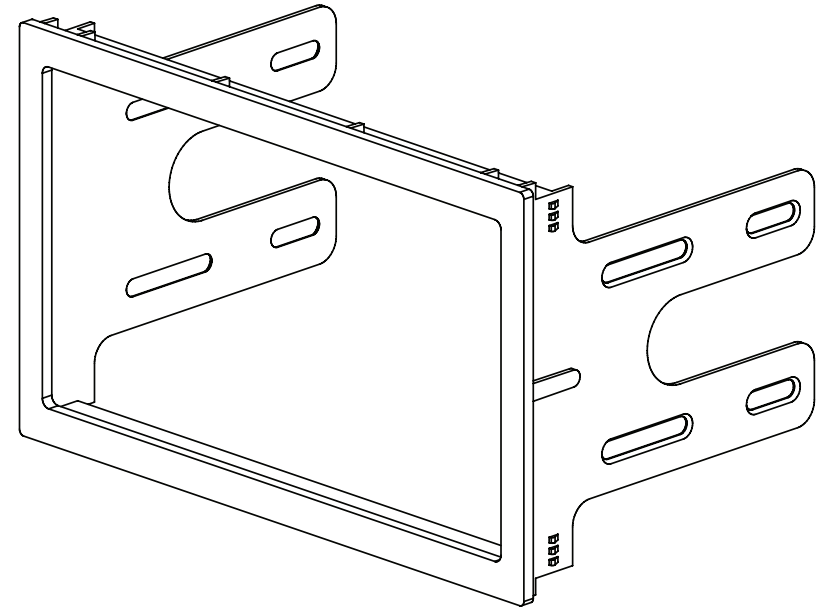

# VWK1015 Mounting Kit



[www.aampglobal.com](http://www.aampglobal.com) [www.aius.net](http://www.aius.net)

2500 East Francis Street Ontario, CA 91761, U.S.A.

Sales: (800) 477-2267

Intl: (727) 572-9255

Support: 888-228-5560

## VEHICLE APPLICATION

### Volkswagen

2002	CABRIO
1999-07	GOLF
1999-05	GTI
1999-05	JETTA
2002-05	JETTA GLI
1998-05	PASSAT