

AudioControl®

Making Good Sound Great™

Features

- Performance-Oriented Design
- Carpeted Exterior Finish
- Decorative Suede Insert
- Adaptive Terminal Cup
- Composite Foam Surround
- High-Temperature, Lightweight Voice Coil
- Large-Gauge, Quick-Release Black Nickel Terminals

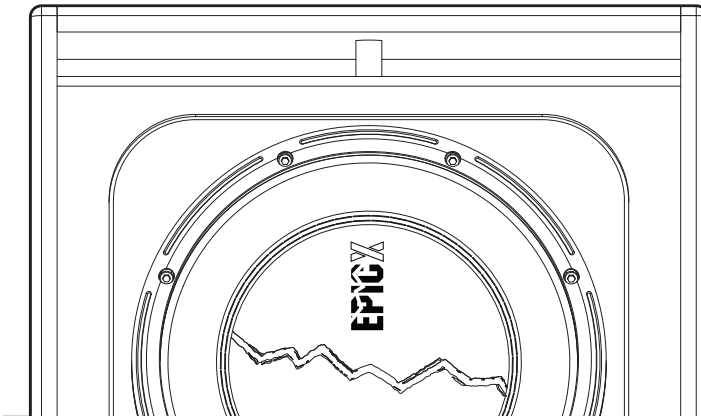

EPICX

SUBWOOFER ENCLOSURES

EPICXV8 | EPICXV10 | EPICXV12

User Guide

Important Safety Instructions

1. Read these instructions.
2. Keep these instructions.
3. Heed all warnings.
4. Follow all instructions.
5. Do not submerge this apparatus in water.
6. Clean only with a dry cloth.
7. **WARNING:** The subwoofer enclosure must be properly secured in the vehicle. Improper installation may lead to permanent injury or death. Installation of the speaker enclosure must be done with great care by qualified personnel, to prevent damage to fuel lines, power and other electrical wiring, hydraulic brake lines, and other systems, that might compromise vehicle safety.
8. Use speaker wire of sufficient size to ensure adequate current to the speaker. For EPICX Series Subwoofers, this means 10-14 gauge speaker wire.
9. To prevent excessive cone excursion and potential damage to the subwoofer it is advisable to use an infrasonic (subsonic) filter set 1/2 octave below Fb. (Hz)
10. Refer all servicing to qualified service personnel. Servicing is required when the apparatus has been damaged in any way, such as the power input terminals are damaged, objects have fallen into the apparatus, does not operate normally, or has been dropped.
11. Not tested for use in vehicles powered by hopes and dreams.
12. Exposure to high sound pressure levels may lead to permanent hearing loss. Take every precaution to protect your hearing.

The exclamation point within an equilateral triangle is intended to alert the user of the presence of important operating and maintenance (servicing) instructions in the literature accompanying the appliance.



Recycling notice: If the time comes and this apparatus has fulfilled its destiny, do not throw it out into the trash. It has to be carefully recycled for the good of mankind, by a facility specially equipped for the safe recycling of electronic apparatus. Please contact your local or state recycling leaders for assistance in locating a suitable nearby recycling facility. Or, contact us and we might be able to repair it for you.



This blank page brought to you by suspense. Turn over for the grand reveal.

Enclosure Talk

Right on! You got yourself a shiny new AudioControl enclosure. After you're done admiring the quality workmanship and attention to detail, you need to get this earth shaking enclosure installed. If you did not attend auto-shop in school or are having trouble plugging in power tools, your best bet is to seek out a qualified AudioControl dealer. They have the skills, experience, and specialized tools to get your vehicle sounding like a live concert and they usually smell alright, too.

If you provide your subwoofer with too much power, it can lead to distortion and potential damage. **Overpowering** causes the cone to move outward beyond its intended limits, resulting in issues such as tearing the cone, spider, and surround, ultimately destroying the subwoofer. Conversely, if the signal instructs the voice coil to move too far backward and it may crash into the back plate of the magnet assembly, causing damage to the coil and former. To avoid potentially damaging your subwoofer, it is crucial to match the RMS power ratings of your subwoofer and amplifier accurately. Additionally, setting the amplifier's gain correctly helps prevent distortion and excessive power delivery.

Underpowering a subwoofer itself isn't necessarily harmful, but problems can arise if the amplifier sends out a clipped signal. Clipping happens when the audio signal exceeds the amplifier's capacity, causing distortion.

A clipped signal attempts to move the subwoofer's cone too quickly, forcing it into rapid, excessive motions. This can cause the subwoofer to jam or damage the voice coil. In some cases, the clipped signal causes the voice coil to remain still for prolonged periods, leading it to overheat. This overheating can result in deformation and permanent damage to the subwoofer's voice coil.

To prevent this, make sure your amplifier is not overworked and is not producing a clipped signal. Properly matching RMS power ratings and setting the crossover correctly are essential steps to avoid distortion, protect your subwoofer, and ensure optimal performance.

Over-excursion refers to pushing a subwoofer past its mechanical limits. Subwoofers are more susceptible to over-excursion due to their need for significant cone movement to produce low frequencies.

Proper Break-In: Give your subwoofer's suspension time to stabilize by following the recommended break-in period. This ensures the suspension components, such as spiders and surrounds, exhibit control and longevity.

Understanding subwoofer performance and taking the necessary steps to prevent damage are crucial for achieving the best audio experience and ensuring the longevity of your subwoofer. Proper break-in, and subsonic crossover usage are essential practices to prevent damage. By following these guidelines and avoiding distortion, you can enjoy powerful and precise bass without compromising your subwoofer's performance and lifespan.

Please visit AudioControl knowledge base site for detailed break-in procedures.

<https://www.audiocontrol.com/knowledge-base>

Adaptive Terminal Cup

This enclosure offers the option to position the terminal cup on either the left or right side. This feature is especially useful when trying to optimize available space in your vehicle, allowing for a more customized and efficient installation.

To relocate the terminal cup:

1. Remove the Terminal Cup

Begin by unscrewing the four mounting screws located at each corner of the terminal cup. Carefully pull the terminal cup away from the enclosure.

2. Disconnect the Speaker Leads

Unplug both the positive and negative speaker leads from the back of the terminal cup.

3. Access the Alternate Mounting Location

Turn the enclosure to the opposite side and remove the cover plate by unscrewing its four mounting screws.

4. Reposition the Speaker Leads

Using a long zip tie or wire puller, route the speaker leads to the newly opened terminal cup location. Connect the positive and negative leads to their corresponding terminals on the back of the terminal cup. Ensure correct polarity when reconnecting the leads.

5. Install the Terminal Cup

Place the terminal cup into the new location and secure it with the four screws previously removed.

6. Cover the Original Opening

Reinstall the cover plate over the original terminal cup location and fasten it using the four mounting screws.

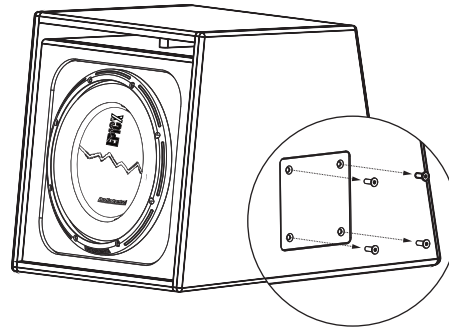
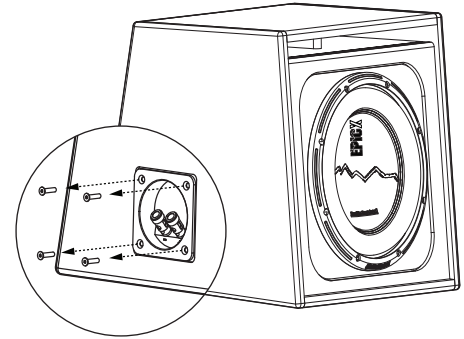

AudioControl®

Making Good Sound Great™

Wow, that was a good time. Now pause for a moment—we're about to get into the serious business of performance.

Maximize Performance

Power it Right

Use the **EPIC500** amplifier.

Perfect power match = no blown subs, no muddy sound.

Clean Power = Happy Bass.

Setting the Gain

1. Start with gain all the way down.
2. Play a bass-heavy track with head unit at 3/4 volume.
3. Raise gain until Maximized light flickers on the loudest note.
4. Back down so the Maximized light glows dimly only on big peaks.

Keeps sound clean without clipping

Subsonic Filter (HPF)

Acts as a safety net:

Too low = unneeded stress.

Too high = lost bass.

Down = more low rumble / added strain.

Up = tighter but less deep bass.

Pro Tip: HPF protects your subwoofer from sounds it can't play efficiently.

Low-Pass Filter (LPF)

Keeps subs playing bass only:

Too high = muddy.

Too low = missing energy.

EPICBOOST (Bass Boost)

Think of **EPICBOOST** as the finishing touch. Get your system dialed in with gain, HPF, and LPF first. Only if you notice a "gap" in your sound, add a little boost:

- Need more low-end weight? Try 30-45 Hz.
- Want more kick in the chest? Go 50-60 Hz
- Missing midbass presence? Add a touch at 70-80 Hz

EPICBOOST is best in moderation—like seasoning or hot sauce, a little enhances the sound, too much overwhelms it and causes clipping.

Tuning Made Simple

1. Start at recommended settings.
2. Lower LPF = more thump.
3. Raise HPF = cleaner punch.
4. Add THE EPICENTER® for ultimate lows.
5. Adjust in small steps.
6. Double-check the gain once more.

Final Step: Enjoy the Ride

Turn it up, lean back, and let your music hit you where it matters — because bass is best when you don't just hear it...you FEEL it!

AudioControl®

Making Good Sound Great™

Specifications

EPICXV8

Speaker size 8 in / 200 mm
 Impedance 1 ohm
 Voice Coil 2 in / 50 mm
 Tuning Frequency 38 Hz
 LPF 85 Hz
 Suggested Amplifier **EPIC500**



EPICXV12

Speaker size 12 in / 300 mm
 Impedance 1 ohm
 Voice Coil 2.38 in / 60 mm
 Tuning Frequency 31 Hz
 LPF 75 Hz
 Suggested Amplifier **EPIC500**



EPICXV10

Speaker size 10 in / 250 mm
 Impedance 1 ohm
 Voice Coil 2.38 in / 60 mm
 Tuning Frequency 33 Hz
 LPF 80 Hz
 Suggested Amplifier **EPIC500**



Dimensions

EPICXV8

Width (A).....	13.11 in / 333 mm
Height (B).....	12.44 in / 316 mm
Depth Top (C).....	10.6 in / 269 mm
Depth Bottom (D).....	14.25 in / 362 mm
Weight.....	27 lbs / 12.25 kg

EPICXV10

Width (A).....	15.43 in / 393 mm
Height (B).....	15.20 in / 386 mm
Depth Top (C).....	12.44 in / 317.5 mm
Depth Bottom (D).....	17 in / 431.8 mm
Weight.....	39 lbs / 17.70 kg

EPICXV12

Width (A).....	16.30 in / 414 mm
Height (B).....	16.37 in / 416 mm
Depth Top (C).....	13.5 in / 343 mm
Depth Bottom (D).....	18.38 in / 467 mm
Weight.....	45 lbs / 20.40 kg

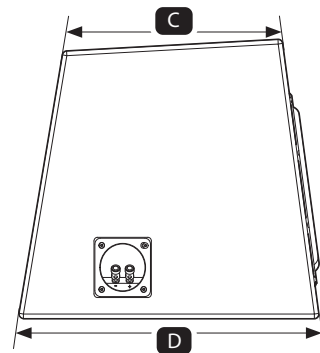
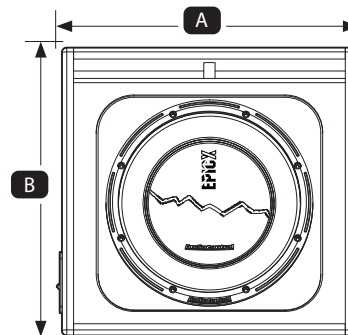

AudioControl[®]

Making Good Sound Great[™]

The Warranty

A Few Words About Warranties

People are scared of warranties. Lots of fine print. Months of waiting around. Well, fear no more—this warranty is designed to make you rave about us to your friends. It's a warranty that looks out for you and helps you resist the temptation to have your friend, "...who's good with electronics," try to repair your AudioControl product. So go ahead, read this warranty, then take a few days to enjoy your new AudioControl processor before registering at <http://audiocontrol.com/product-registration/>.

"Conditional" doesn't mean anything ominous. The Federal Trade Commission tells all manufacturers to use the term to indicate that certain conditions have to be met before they'll honor the warranty. If you meet all of these conditions, we will warranty all materials and workmanship on your AudioControl product for one year from the date you bought it from a Factory Direct authorized AudioControl retailer. We will fix or replace it, at our option, during that time.

Products purchased from unauthorized resellers (including third-party sellers on marketplaces such as Amazon, eBay, or Best Buy) are not covered under AudioControl's warranty. To ensure full warranty coverage, products must be purchased directly from AudioControl/Stinger or from an authorized dealer.

SPEAKERS, SUBWOOFERS AND LOADED ENCLOSURES

One (1) year from the original date of purchase

or

Two (2) years when purchased and installed with an AudioControl amplifier by a Factory Direct authorized AudioControl retailer.

Legalese

Here Are The Conditional Conditions

1. You have to go online and register your AudioControl products.
2. You must keep your sales receipt for proof of purchase showing when and from whom the unit was bought. We're not the only ones who require this, so it's a good habit to get into with any major purchase.
3. Your AudioControl products must have originally been purchased from a Factory Direct authorized AudioControl retailer. You do not have to be the original owner, but you do need a copy of the original sales slip.
4. You cannot let anybody who isn't: **(A)** the AudioControl factory; **(B)** somebody authorized in writing by AudioControl to service your product. If anyone other than **(A)** or **(B)** messes with your AudioControl product, that voids your warranty.
5. The warranty is also void if the serial number is altered or removed, or if your AudioControl component has been used improperly. Now that sounds like a big loophole, but here is all we mean by it. Unwarranted abuse is:
(A) physical damage (don't use it to level your RV);
(B) improper connections (120 volts AC into a 12 volt DC power jack can fry the poor thing);
(C) sadistic things (your imagination is best kept private)... This is the best product we know how to build, but if you mount it to the front bumper of your car or use it as a counter-weight for your daughter's trebuchet project, something will go wrong.
6. Assuming you conform to 1 through 5, and it really isn't all that hard to do, we get the option of fixing your old unit or replacing it with a new one. To initiate a warranty claim, please contact AudioControl and we will issue an RA (Return Authorization) number and provide shipping instructions. Products received at AudioControl without an RA number will be refused.

Legalese Section

This is the only warranty given by AudioControl. This warranty gives you specific legal rights that vary from state to state. Promises of how well your AudioControl component will perform are not implied by this warranty. Other than what we have covered in this warranty, we have no obligation, express or implied. Also, we will not be obligated for direct or indirect consequential damage to your system caused by hooking up your AudioControl component.

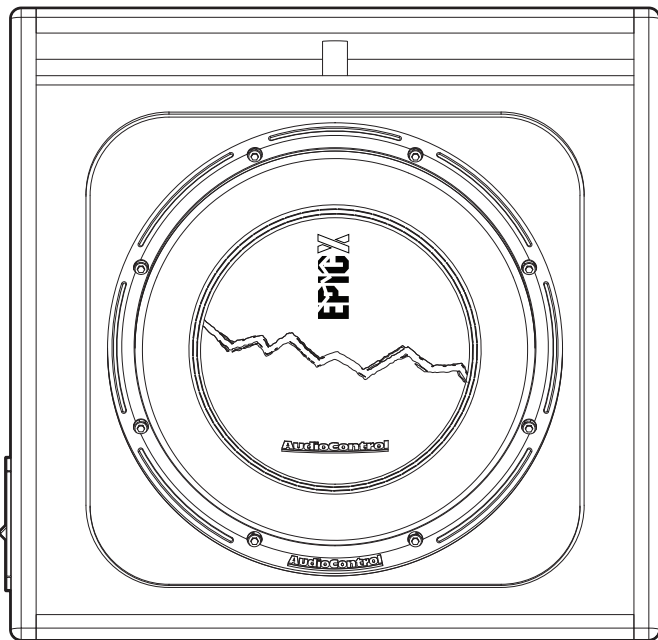

For more information about this fine product, and for additional details of the limited warranty and repair services, please visit www.audiocontrol.com

For technical questions, please visit www.audiocontrol.com/knowledge-base/

AudioControl – “a Stinger Company”

9620 Executive Center Dr N, Suite 200
St Petersburg, FL 33702

Support:

Phone: 425-777-7723

Email: support@audiocontrolmobile.com

©2026 AudioControl. All rights reserved.

As technology advances, AudioControl reserves the right to continuously change our specifications, like our Pacific Northwest weather, although we are working on changing that as well.