



Ford Focus 2012-2018

Visit MetraOnline.com for more detailed information about the product and up-to-date vehicle specific applications

KIT FEATURES

- DDIN provision
- DIN radio provision with pocket sold separately
- Painted scratch resistant matte black
- Integrated button housing for retention of hazard and door locks

KIT COMPONENTS

- A) Radio trim panel • B) Radio brackets • C) Lower trim (2012-2014) • D) Lower trim (2015-2018) • E) Airbag light panel (2015-2018)
- F) Blank button and lock/unlock button • G) Panel clips (2) • H) Phillips screws (2) • I) Hazard/Lock harness (not shown)

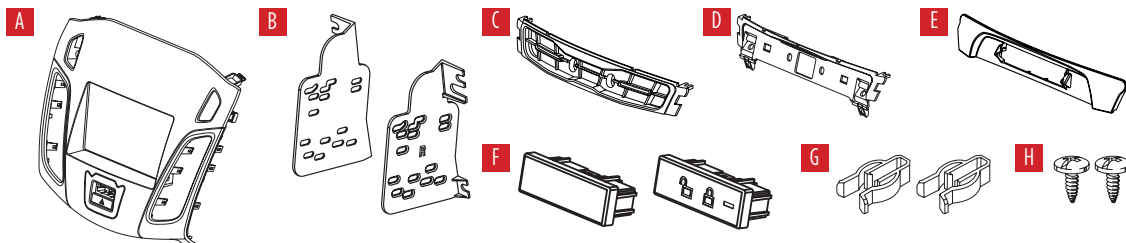

TABLE OF CONTENTS

Dash Disassembly.....	2-3
Kit Preparation.....	4-5
Kit Assembly.....	6

WIRING & ANTENNA CONNECTIONS

Wiring Harness: Visit metraonline.com and axessinterfaces.com for audio/video and steering wheel control interface options.

Antenna Adapter: 40-EU10

TOOLS REQUIRED

- Panel removal tool • Phillips screwdriver
- Socket wrench • Torx screwdriver

Attention! With the key out of the ignition, disconnect the negative battery terminal before installing this product. Ensure that all installation connections are secure before cycling the ignition to test this product.

DASH DISASSEMBLY

2012-2014 Ford Focus

1. Remove the screw cover facing up on the bottom of the radio control panel. (Figure A)
2. Remove (2) T-25 Torx screws from under the cover. (Figure B)

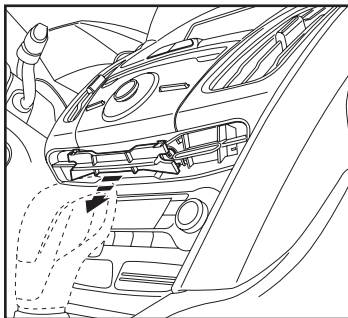

(Figure A)

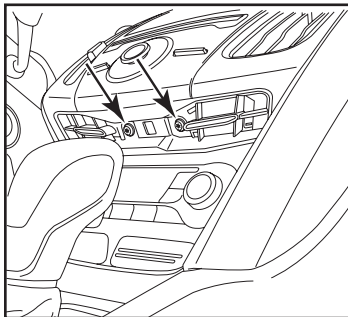

(Figure B)

3. Unclip and remove the entire radio control panel including the A/C vents. (Figure C)
4. Remove (4) T-25 Torx screws securing the radio and (4) T-25 Torx screws securing the factory display and bracket. (Figure D)

Continue to Kit Preparation

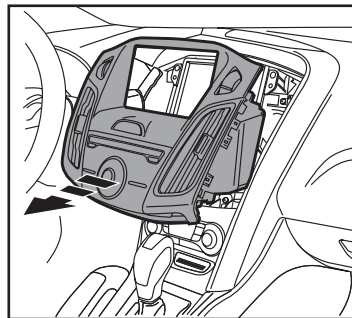

(Figure C)

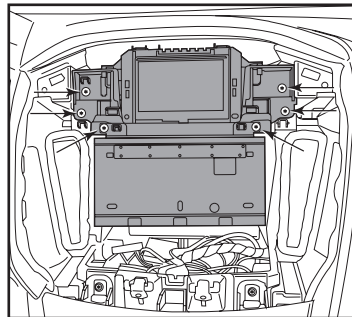

(Figure D)

DASH DISASSEMBLY

2015-2018 Ford Focus

1. Unclip, unplug, and remove the trim panel with the passenger airbag light in it. Keep the airbag light for Kit Preparation. (Figure A)
2. Unclip and remove the trim panel around the shifter panel. (Figure B)
3. Remove (3) Phillips screws securing the shifter panel, then unclip and slide the shifter panel toward the rear of the vehicle. (Figure C)

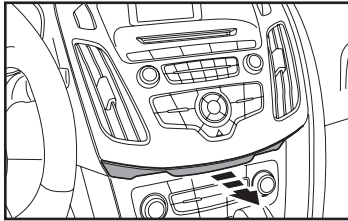

(Figure A)

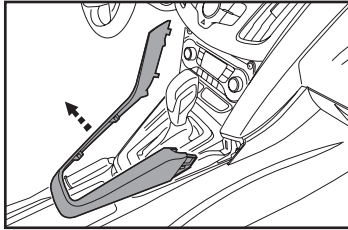

(Figure B)

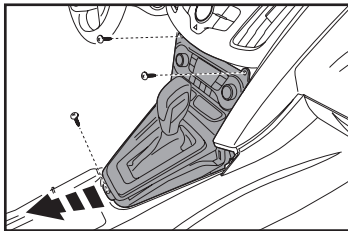

(Figure C)

4. Remove (2) T-25 Torx screws from the bottom of the radio panel. (Figure D)
5. Unclip, unplug and remove the radio control panel including the A/C vents. (Figure E)
6. Remove (2) T-25 Torx screws securing the radio, and (4) T-25 Torx screws securing the display and bracket, and then unplug and remove. (Figure F)

Continue to Kit Preparation

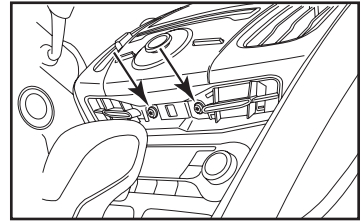

(Figure D)

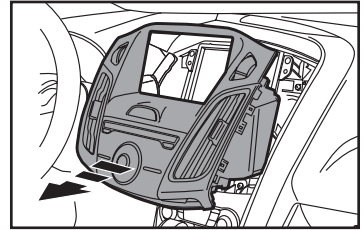

(Figure E)

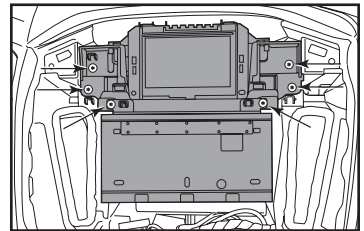

(Figure F)

KIT PREPARATION

2012-2014 models

From the factory radio panel:

1. Unclip and remove the A/C vents from the factory radio panel. (Figure A)
2. Secure the 2012-2014 **lower trim** to the **radio trim panel** with the supplied Phillips screws. (Figure B)

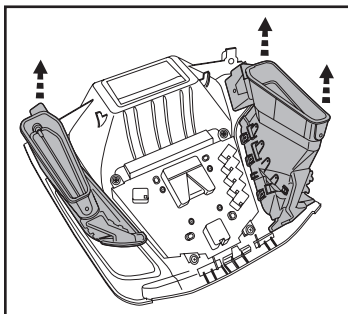

(Figure A)

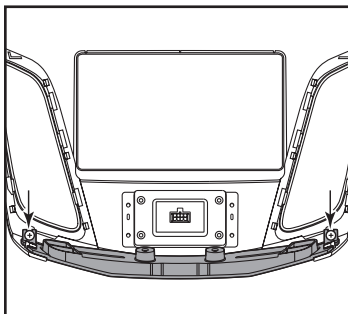

(Figure B)

3. Clip the A/C vents, removed from Step 1, onto the **radio trim panel**. (Figure C)
4. Snap the **lock/unlock button** into the upper location of the button housing in the **radio trim panel**. (Figure D)

Continue to Kit Assembly

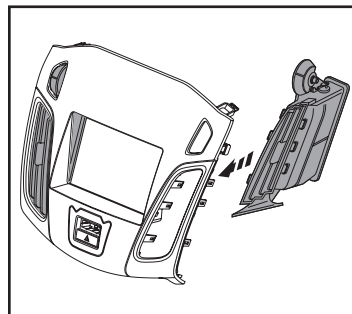

(Figure C)

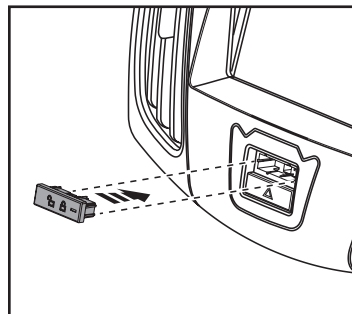

(Figure D)

KIT PREPARATION

2015-2018 models

From the factory radio panel:

1. Unclip and remove the A/C vents from the factory radio panel. (Figure A)
2. Install the (2) **panel clips**, and the factory passenger airbag light, to the **passenger airbag light panel**. (Figure B)

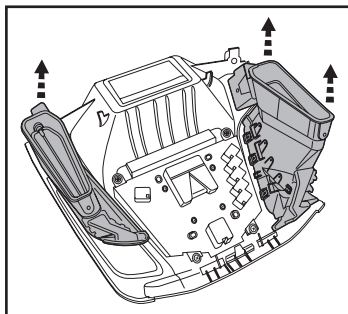

(Figure A)

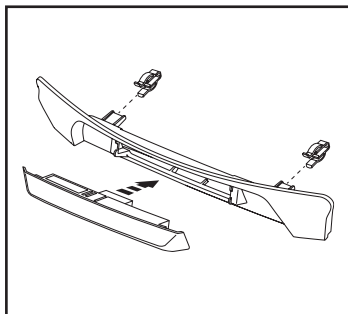

(Figure B)

3. Secure the 15-18 **lower trim panel** to the **radio trim panel**. (Figure C)
4. Clip the factory A/C vents onto the **radio trim panel**. (Figure D)
5. Snap the **blank button** into the upper location of the button housing in the **radio trim panel**. (Figure E)

Continue to Kit Assembly

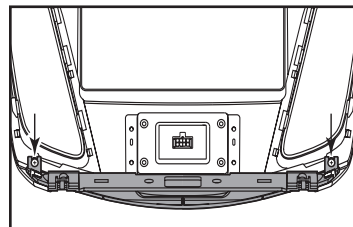

(Figure C)

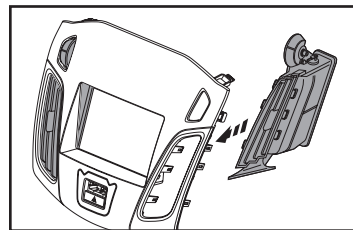

(Figure D)

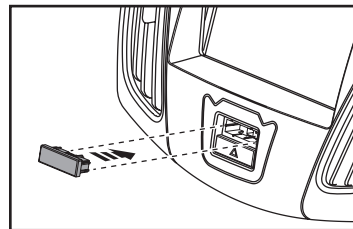

(Figure E)

KIT ASSEMBLY

1. Attach the **radio brackets** to the radio using screws supplied with the radio, and then secure into the dash opening. (Figure A)
2. Locate the factory wiring harness and antenna connector in the dash, and complete all necessary connections to the radio. Metra recommends using the proper mating adapter from Metra and/or AXXESS. Re-connect the negative battery terminal and test the radio for proper operation.
3. Connect the **hazard/ lock harness** to the proper vehicle plug and then to the radio trim panel.
4. Snap the **radio trim panel** over the radio and reassemble the dash in reverse order of disassembly.
Note: For the 15-18 pull the plug through the airbag light opening during installation.
5. For the 15-18 Install the **passenger airbag light assembly** into the **radio trim panel**.

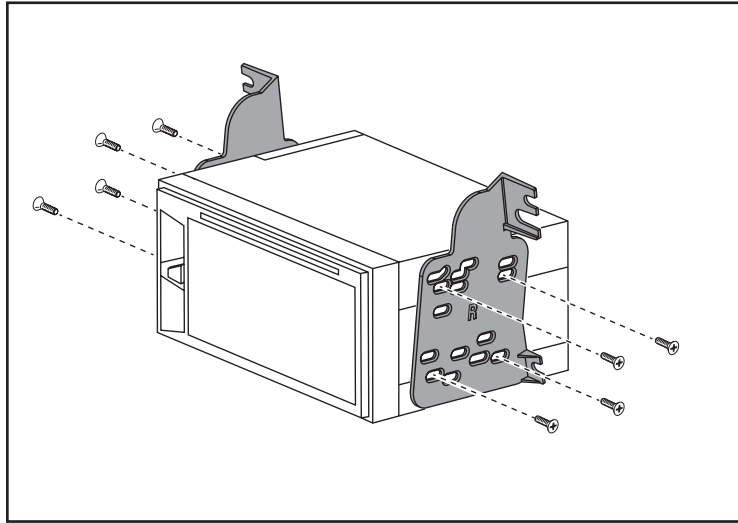

(Figure A)



95-5871B
INSTALLATION INSTRUCTIONS



Having difficulties? We're here to help.



Contact our Tech Support line at:
386-257-1187



Or via email at:
techsupport@metra-autosound.com

Tech Support Hours (Eastern Standard Time)

Monday - Friday: 9:00 AM - 7:00 PM

Saturday: 10:00 AM - 5:00 PM

Sunday: 10:00 AM - 4:00 PM



**Metra recommends MECP
certified technicians**